



**ULTIMATRON
FRANCE**

**5 YEARS
WARRANTY**

Technical sheet

ULTIMATRON LiFePO4 Smart BMS Underseat of Camping Car 12.8V 180Ah with Heater

Compared with traditional batteries, our lithium iron phosphate batteries (LiFePO4) has many advantages:

- 5 year manufacturer's warranty
- The safest technology, without risk of fire or explosion
- Long service life
- Constantly improving storage capacity
- High stability even under extreme loads
- No memory effect, no need for full charge and discharge cycles
- High performance even under extreme conditions
- Deep and regular discharge and charging efficiency
- Small size and light weight



Integrated Battery Management System (BMS)

To allow the control and the charge of the different elements of an accumulator battery and to protect it against overcharging, overvoltages and overheating.



Note: Series and parallel connection for 12V, 24V, 36V, 48V applications.



Integrated Bluetooth 4.0 monitoring



You have all important battery data always on your smartphone or tablet. The application displays the data in real time.





**ULTIMATRON
FRANCE**

TECHNICAL SHEET

ULM SMART BMS SERIE 12.8V

ULTIMATRON LiFePO4 Smart BMS 12.8V 180Ah with Heater

ELECTRICAL PERFORMANCE

Nominal Voltage	12.8 V
Nominal Capacity	180 Ah
Capacity @ 36A	300 min
Energy	2304 Wh
Resistance	≤20 mΩ @ 50% SOC
Self Discharge	<3% / Month
Cells	32700 Cell 3.2V6Ah

CHARGE PERFORMANCE

Recommended Charge Current	20 A
Maximum Charge Current	50 A
Recommended Charge Voltage	14.6 V
Charge Cut-Off Voltage	<15.2 V (0.5 ~ 1.5 s)
Reconnect Voltage	>14.4 V
Balancing Voltage	<14 V
Maximum Batteries in Series	4

DISCHARGE PERFORMANCE

Continuous Discharge Current	50 A
Maximum continuous Discharge Current	150 A
Peak Discharge Cut-Off Current	450 A (5 ~ 15 ms)
Recommended Low Voltage Disconnect	10 V
Discharge Cut-Off Voltage	>8.4 V (50 ~ 150 ms)
Reconnect Voltage	>10 V
Short Circuit Protection	200 ~ 600 μs

MECHANICAL PERFORMANCE

Dimension (L x W x H)	357 x 338 x 152 mm
Weight	23.7 kg
Terminal Type	M8
Terminal Torque	80 ~ 100 in-lbs (9 ~ 11 N-m)
Bluetooth	Bluetooth 4.0 with smartphone app
Case Material	Metal
Enclosure Protection	IP65
Low temperature heating	< 0 °C charging and heating

DIMENSION

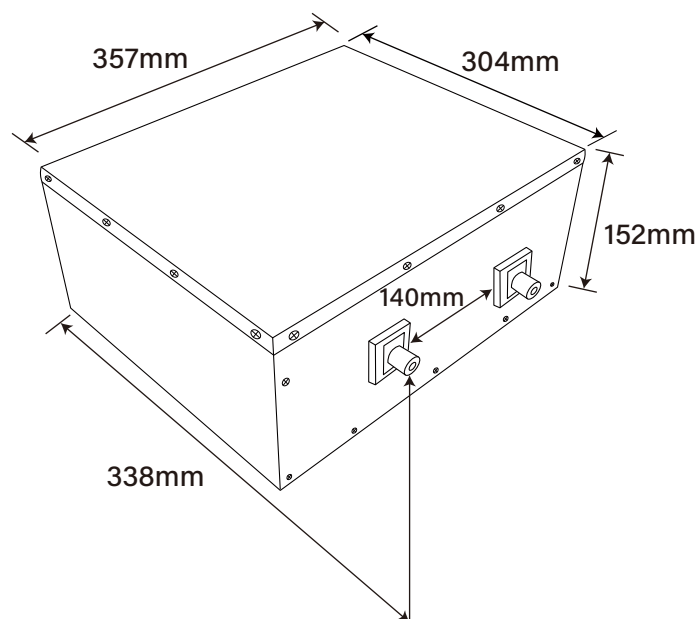

Dimensions L357 * W338 * H152 mm

TEMPERATURE PERFORMANCE

Discharge Temperature	-20 ~ 60 °C
Charge Temperature	0 ~ 45 °C
Storage Temperature	-5 ~ 35 °C
High Temperature Cut-Off	65 °C
Reconnect Temperature	48 °C

COMPLIANCE

Certifications	CE UN38.3 UL1642 & IEC62133
Shipping Classification	UN 3480, CLASS 9

ULTIMATRON FRANCE

Add: 60 Avenue de l'industrie 34820 Teyran, France

✉ info@ultimatron-france.fr

☎ Tel: +33(0)9 50 42 76 17

