

## TRUDESIGN™ Ball Valves

Designed and made in New Zealand TRUDESIGN Certified Ball Valves are specifically designed for use in marine applications above and below the water line.

- Certified to ISO 9093-2 by the International Marine Certification Institute (IMCI, Belgium) when fitted to TRUDESIGN Skin Fittings (Thru Hulls)
- Comply with ABYC H-27 standards when (where needed) used in conjunction with the TRUDESIGN ABYC collar and Skin Fittings (Thru Hulls).
- Certified by Bureau Veritas to ISO 9093-2.



### Features

- Manufactured from a glass-reinforced Nylon composite – High strength, tough and light weight.
- Immune to corrosion & electrolysis – No corrosion or breakages, increased safety.
- Electrically non-conductive. No electrical bonding.
- Suitable for use on all hull types - aluminium, steel, wood or FRP.
- The ball and sealing rings utilise a PTFE polymer to ensure a smooth action and minimal fouling of the internal ball.
- The Ball Valve can be locked in the closed position to comply with toilet waste outlet regulations.
- Large operating range – Suitable for all marine conditions from  $-40^{\circ}\text{C}$  to  $+110^{\circ}\text{C}$
- Available in both BSP and NPS thread forms.
- Can be used in Engine Rooms
- “T” Handle or “Lever” Handle options.
- Handle Identification Tags available to easily identify Ball Valve Function.
- U.V resistant – No degradation from the sun’s ultraviolet rays.
- 100% leak tested before leaving factory.

## Features Continued

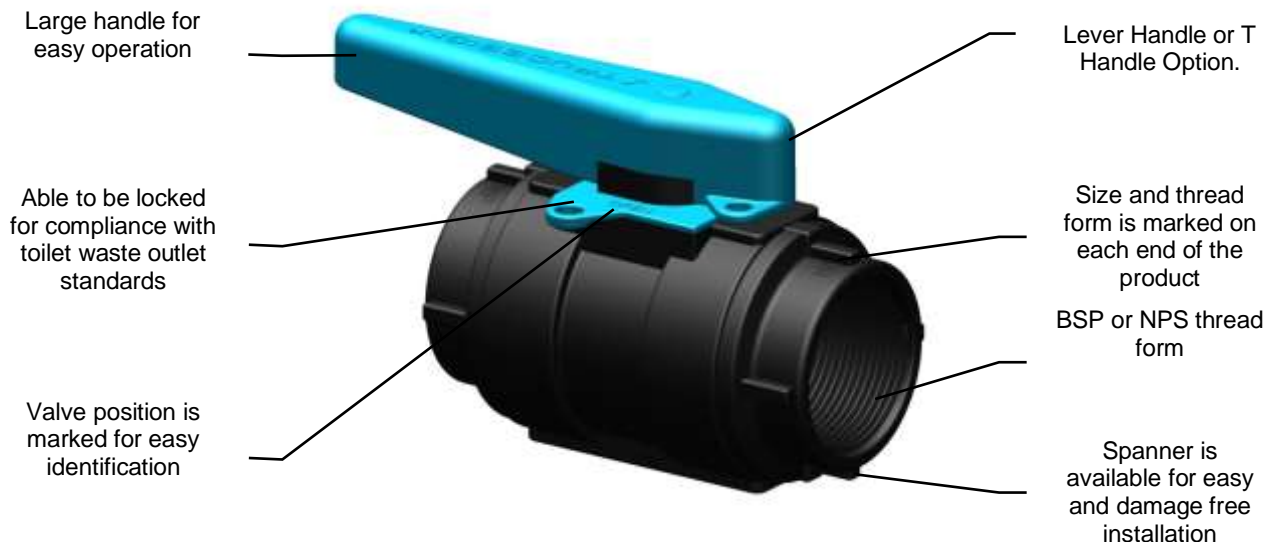

### BSP Part Numbers “Lever Handle”

Part Number	Description
90471	Ball Valve ½" BSP
90548	Ball Valve ½" BSP PKG
90276	Ball Valve ¾" BSP
90549	Ball Valve ¾" BSP PKG
90242	Ball Valve 1" BSP
90550	Ball Valve 1" BSP PKG
90240	Ball Valve 1¼" BSP
90551	Ball Valve 1¼" BSP PKG
90235	Ball Valve 1½" BSP
90552	Ball Valve 1½" BSP PKG
90472	Ball Valve 2" BSP
90553	Ball Valve 2" BSP PKG
91157	Ball Valve 3" BSP with Tag

### BSP Part Numbers – “T” Handle

Part #	Description
91145	Ball Valve ½" BSP T Handle
91140	Ball Valve ¾" BSP T Handle
91141	Ball Valve 1" BSP T Handle
91142	Ball Valve 1¼" BSP T Handle
91143	Ball Valve 1½" BSP T Handle
91144	Ball Valve 2" BSP T Handle

Note PKG – denotes item packaged in branded plastic Bag

## NPS Part Numbers – Lever Handle

Part #	
90647	Ball Valve ½" NPS
90648	Ball Valve ¾" NPS
90649	Ball Valve 1" NPS
90650	Ball Valve 1¼" NPS
90651	Ball Valve 1½" NPS
90652	Ball Valve 2" NPS

## Weight

Internal Diameter	Thread Size	Weight (g)	Weight (oz)
19mm [¾"]	½", ¾", 1"	300	10.6
32mm [1¼"]	1¼", 1½"	450	15.9
52mm [2"]	2"	700	24.7
75mm (3")	3"	1,510	53.3

## Thread Sealing

Ensure the skin fitting (Thru Hull) and ball valve location enables full operation of the valve handle. See also our info sheet on TRUDESIGN skin fitting installation. The following sealing methods can be used. In all cases refer to manufacturer's product literature.

- 3M™ Marine Adhesive Sealant Fast Cure 5200. A one-part polyurethane adhesive/sealant. Starts to cure (tack-free) in approximately 2 hours, after which hoses can be attached. Full cure takes 24 hours.
- SIKAFLEX® 291i and 591 Marine Sealants.
- Bostik® 920 Marine Sealant. A one-part urethane adhesive/sealant. Starts to cure (tack-free) in approx. 2 hours, after which hoses can be attached. Full cure takes 1.5 – 3 days.
- 3M™ Marine Adhesive Sealant Fast Cure 4200 is approximately half the strength (once cured) of 3M 5200 which allows for eventual disassembly of the ball valve from skin fitting.
- LOCTITE® 5331 A one-part acetoxysilicone sealant. Starts to cure (tack-free) in approx. 10 minutes, after which hoses can be attached. Full cure is achieved within 12 hours (at min. 40% atmospheric humidity) – refer to product literature. Creates a permanent seal for threaded connections.
- PTFE (Teflon) Thread Tape is a traditional thread sealing method which provides a good seal when applied correctly. However, in some cases if the position or tightness of the Ball Valve is incorrect, it will need to be unscrewed and more tape applied, slowing the assembly process. Additionally, the fittings can sometimes be turned by hand after being installed.
- LOCTITE® 55 Pipe Sealing Cord is a coated multi-filament cord designed as a faster method than Teflon tape to seal threaded fittings. The main advantage is that a component, for example a Ball Valve, could be screwed down then screwed back a turn to suit positioning whilst still maintaining a tight seal. This eliminates the need to remove the entire Ball Valve and apply more tape as with traditional Teflon tape.

## Fitting

Screw Ball Valve onto the skin fitting (Thru Hull) using the correct Ball Valve Spanner (available from TRUDESIGN), or another appropriate tool. Tighten to a maximum of 16Nm (12ft/lbs).

Check that the final position of the Ball Valve is such that it allows full movement of the handle from the open to closed position, and that it is clear of objects which may cause inadvertent operation.

Note: The connecting threads on each end of the Ball Valves are a parallel thread form. The advantage of parallel threads over tapered is that there is maximum engagement between the mating threads providing a strong and watertight seal. Mixing parallel and tapered threads can cause strength and sealing problems as the engagement can in some cases be only a few turns.

## Replacement “T” and “Lever” Handles

Part #	Description
91038	Replacement “ <b>T</b> ” handle Small – 25mm,19mm,13mm (1”, ¾”, ½”)
91040	Replacement 'T' Handle Large – 50mm-38mm-32mm (2”, 1½”, 1¼”)
91155	Replacement <b>Lever</b> Handle Small 25mm-19mm-13mm (1”, ¾”, ½”)
91156	Replacement <b>Lever</b> Handle Large 50mm-38mm-32mm (2”, 1½”, 1¼”)
91290	Replacement Lever Handle 3”



## Ball Valve Spanner

90476	Spanner / Wrench Ball Valve ½” PKG
90477	Spanner / Wrench Ball Valve ¾” & 1” PKG
90478	Spanner / Wrench Ball Valve 1¼” & 1½” PKG
90479	Spanner / Wrench Ball Valve 2” PKG



**Ball Valve Handle Tag** – Identification Tags are available that easily fit onto the Lever Handles. See Separate Product Information Sheet.



## Dimensions -

A	B		C		D		E		F		Lever Handle				T-Handle	
	Size	Length		Length		Height		Width		Minimum Internal $\varnothing$		G		H		I
½"	25mm	1"	102mm	4"	88mm	3 4/9"	61mm	2 3/8"	20mm	3/4"	32mm	1 1/4"	93mm	3 2/3"	50mm	2"
¾"	22mm	6/7"	102mm	4"	88mm	3 4/9"	61mm	2 3/8"	20mm	3/4"	32mm	1 1/4"	93mm	3 2/3"	50mm	2"
1"	22mm	6/7"	102mm	4"	88mm	3 4/9"	61mm	2 3/8"	20mm	3/4"	32mm	1 1/4"	93mm	3 2/3"	50mm	2"
1 ¼"	32mm	1 1/4"	122mm	4 4/5"	102mm	4"	76mm	3"	32mm	1 1/4"	38mm	1 1/2"	108mm	4 1/4"	57mm	2 1/4"
1 ½"	32mm	1 1/4"	122mm	4 4/5"	102mm	4"	76mm	3"	32mm	1 1/4"	38mm	1 1/2"	108mm	4 1/4"	57mm	2 1/4"
2"	32mm	1 1/4"	141mm	3"	124mm	4 6/7"	99mm	3 7/8"	48mm	1 8/9"	38mm	1 1/2"	108mm	4 1/4"	57mm	2 1/4"
3"	46mm	1 4/5"	205mm	8"	180mm	7"	153mm	6"	75mm	3"	50mm	2"	160mm	6 2/7"	-	-

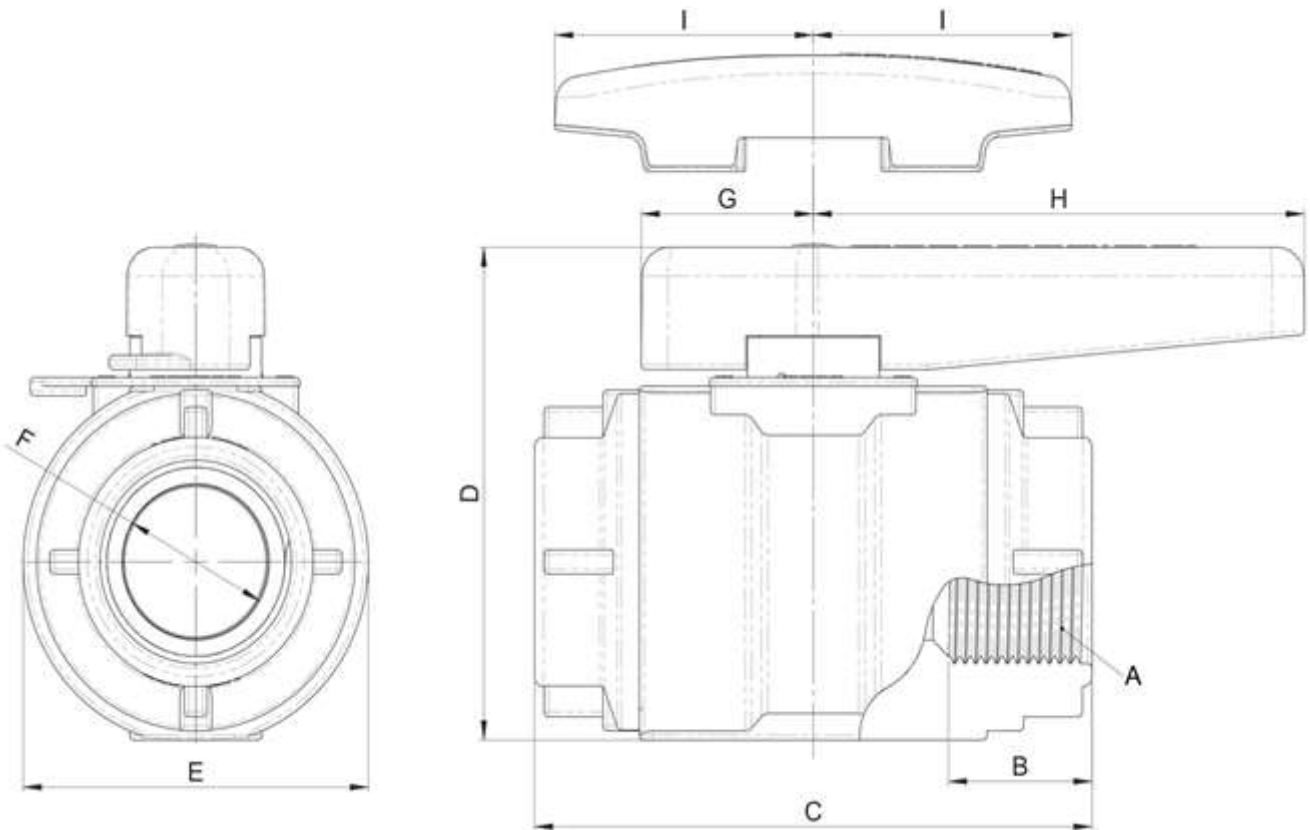

The information contained in this information sheet is for general information purposes only. The information is provided by TruDesign™ and while we endeavour to keep the information up to date and correct, we make no representations or warranties of any kind, express or implied, about the completeness, accuracy, reliability, suitability or availability. Any reliance you place on such information is therefore strictly at your