

VACUUM HYDRO-SYSTEM

Complies with ISO 8846 MARINE [Ignition protection].

The vacuum hydro-system toilet has been designed to comply with the latest anti-pollution regulations forbidding the discharge of sewage effluent within the 3 miles coastal limit. This toilet is able to operate with a very low water consumption (from 1 up to 5 litres) per cycle, which means a longer autonomy of operation of the water holding tanks. The vacuum model has been given a new and smart line. This very comfortable toilet is equipped with a device keeping the bowl always clean and it is much more noiseless than similar systems already on the market. Furthermore, it is also possible to employ a surge pump already installed on board, if any, or to make use of one only pump to get several toilets working.

1. Single vacuum hydro-system

The single vacuum hydro-system is equipped with two separate pumps : the first one for water inlet and the second for water discharge. The inlet pump must be installed outside the bowl. The motor hollow or the bilge (to have less noisiness) near the sea-water intake valve could be a suitable place. The self-priming inlet pump is to be connected to the inlet pipe just after the sea-water intake and the safety handle valve. The inlet pipe must be positioned in its turn at least 50 cm. higher than the sea level. In case of installation under the sea level, a direct discharge ventilation valve (siphon break) is to be installed on the highest point of the inlet pipe. You will have then to connect the pipe to the back side of the bowl.

2. Centralized vacuum hydro-system

The centralized vacuum hidro-system needs for its working a pre-existent salt or fresh water pressured piping (2,5 or 3,5 bar). Therefore, you must connect the water pipe to the electrovalve and then to the rubber holder on the rear side of the bowl.

3. Single and centralized vacuum hydro-system

The outlet macerator pump, which is located in the bowl, provides for the discharging of dirty waters. The outlet pipe having an inside diameter of mm. 38, must be connected to the back side of the bowl after the one-way valve made of black rubber. In case of installation under the sea level, as well as in case of direct discharging, the outlet pipe must build a siphon at 50 cm. at least above the sea level and a ventilation valve must be installed on its highest point (siphon break). In case of head outlet, the outlet pipe coming out of the bowl must go up immediately.

Electric connections

For a correct working of the toilet, the connections have to be made with the correct size wires (see table below). The circuit for the toilet power supply has to be independent and cannot be used for any other appliance. Connect the battery positive terminal to a fuse of adequate capacity load. The fuse has then to be connected next to the battery, in order to protect the feeding line in case of fault.

Connect the electronic switch wires as follows :

1. White wire to the battery positive wire
2. Brown wire to the positive (brown) wire of the water outlet pump
3. Blue wire to the negative (blue) wire of the water outlet pump
4. Grey wire to the battery negative wire
5. Black wire to the negative wire of the water inlet pump or electrovalve
6. Red wire to the positive wire of the water inlet pump or electrovalve

CAUTION:

A correct motor polarity (red and brown wires to positive - blue and black wires to negative) is very important. A reverse polarity can damage the motor, thus voiding the warranty. For a correct functioning of the toilet, a full voltage to the motor is indispensable. Do not connect any other electrical appliances to the electric line of the bowl. Do not replace the supplied connecting plugs.

Wire size per meters of run					
VOLTAGE	AMP.DRAW.	FUSE SIZE	6-10 m.	3-6 m.	0-3 m.
32 Volts d.c.	6	10	8	6	4
24 volts d.c.	8	20	14	10	8
12 Volts d.c.	16	25	16	12	10

Technical specifications :

Voltage :	:	12/24 Volt DC
Inlet pump consumption (single)	:	9 A/ 4.5 A
Electrovalve consumption (centralized)	:	1 A / 0.5 A
Outlet pump consumption	:	18 A/ 10 A
Fuse	:	30 A.
Inlet pump	:	1.2mt. self-priming, capacity 8-12-18 lt./min.
Outlet pump	:	centrifugal, capacity 200 lt./min.
Inlet pipe	:	rubber pipe minimum internal dia. mm. 19
Outlet pipe	:	rubber pipe minimum internal dia. mm. 38
Discharging head	:	5 meters upright

REMARKS :

From the "off" position, by pressing the "before use" button the bowl will be automatically filled up to the correct water level of 1 cm. above the outlet hole inside the ceramic bowl. However, according to the different methods of installation, an adjustment of the water level could be needed. This can be done by rotating the shaft on the inside of the bowl control panel (see exploded view) The short Use is ideal in case a much reduced water consumption is needed. It is particularly employed for the evacuation of liquid organic wastes

Interventions in case of working problems

1. Non arrival of clean water :
 - check the fuse
 - press the “before use” button to check that the main supply regularly reaches the control panel and the inlet pump (single system) or the electrovalve (in case of centralized systems)
2. Outlet pump not working :
 - check the fuse
 - turn to a minimum the timer shaft on the control panel back side and then press the “after use” button, to check that the main supply regularly reaches the control panel and the outlet pump
 - after verifying the previous points, inspect the outlet pump located under the bowl in this way :
 - disconnect the main supply from the bowl
 - remove both floor locking screws from the bowl (the two screws located on the rear side of the bowl)
 - by using a screwdriver or a pipe wrench loosen the metal clamp and remove the rubber coupling sleeve between bowl and pump
 - check that the impeller may freely turn and no objects are trapped inside the pump
 - re-assemble the coupling sleeve, tighten the clamp and fix the bowl to the floor again
3. In case of repeated breakage of the fuse :
 - follow the same instructions as Point 2

OPERATING:

Control panel with 3 switches

Our toilets with 3 switches control panel has been studied to remain empty when it is not used.

Before using, the bowls is automatically filled so ceramic surface with never be dirty from organic residuals.

AFTER USE the bowl is automatically flushed and cleared out.

Operating instructions:

- a) before use press “ before use “ button
- b) after use press “ after use “ button
- c) short use: single function for the evacuation of liquid organic wastes

Bidet for marine toilets:

Open a single level tap and adjust the temperature.

At the end, press the discharge button in order to clear out.

The discharge button must be pressed before the bowls is completely full.

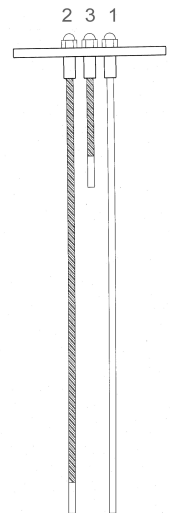

VERY IMPORTANT: picture number 1

Adjust the circuit of flow after disassembling the system :

- + turn on the LEFT the shaft trimmer the water flow will be increased
- turn on the RIGHT shaft trimmer the water flow will be reduced

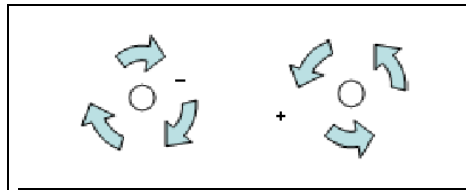

To assure a perfect running of the toilet, on pressing the “before use” button water will have to get about 5 cm. higher than the round hole level.

SYSTEM AND TANK LEVEL INDICATOR

Code of the 12 V. and 24 V. level indicator: 6500002003 WATER VACUUM

Probe-holder hole: 74 mm.

Combination	Combination	Reference
printed circuit / colour wires / probes	probes – colours	colour wires
BIANCO - WHITE	probe 1 + lunga	+ long comune/common
VERDE/ AZZURRO	- GREEN/SKYBLUE	probe 2 + lunga + long ¾ serbatoio –
GIALLO - YELLOW	probe 3 + corta	+ short pieno / full

- PICTURE N. 2
- 1) White Earth
 - 2) Green Reserve Tank
 - 3) Yellow Full
- Red + Battery
Black - Battery

Attenzione: i cavi da attaccare sulla sonda sono quelli già completi di faston.

Caution: the wires to be connected to the probe are those already complete with faston

Coupling. Attention: les câbles à connecter avec la sonde sont ceux déjà complets avec jonction faston.

Vorsicht: die am Fuehler anzuschliessenden Kabel sind jene, die mit Fastonschaltung schon ausgestattet werden

YOU WILL NEED THE LEVEL INDICATOR CABLE ONLY IN CASE YOU PROVIDE FOR THE MOUNTING OF THE LEVEL INDICATOR

RINSE OPTIONS

(1) Fresh Water



(2) Raw Water

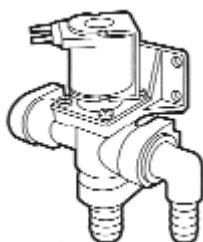

1) Diaphragm pump :optional

remote mounted self-priming pump to bring in sea, river or lake rinse water. Complete with Pumpgard strainer.

2) solenoid valve: optional

assembly for connection to any existing pressurized water system capable of delivering 2.9 US gpm (11 lpm) or more. Upon request is available the NON RETURN VALVE ensures there is no backflow from the toilet into the water system.

FIXING:

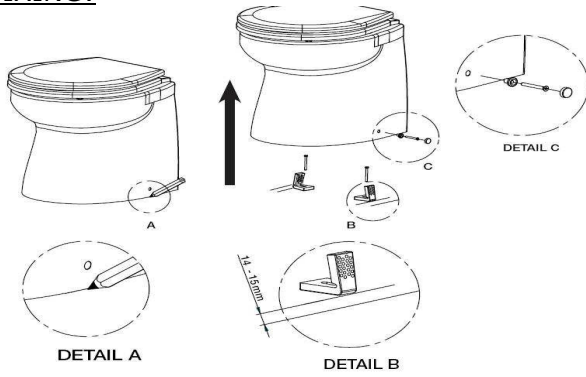

- Now we recommend finishing the rest of the installation (plumbing, electric, etc)
1. Put the toilet in the selected position.
 2. Using the two holes in the toilet and the outer line of the toilet as guide, mark the location and outer line of the bowl of the holes in the toilet on the.
 3. Remove the bowl.
 4. Re-draw a new parallel line approximately 14-15 mm inside of the line you did in step 2.
 5. Put the assembly bracket on the floor, with the slot horizontal.
 6. Mark the middle position of the slot and drill a Ø5mm hole for each bracket.
 7. Tighten the bracket by using the enclosed Ø6,2mm screws. (Ensure that they are not too long for your installation)
 8. Put the toilet back in the selected place.
 9. Put the one plastic sleeve in each assembly hole on the toilet.
 10. Secure the toilet by using the Ø4,7mm screws. As the bracket has a lot of small holes, you can make a small final position adjustment.
 11. Put the screw cover on the screw head.
 12. Use the sealant around the base, towards the floor.

ELECTRICAL WIRING

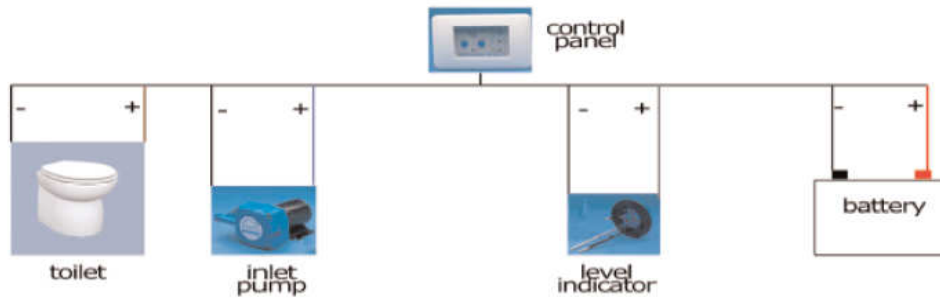

DIMENSIONS

Deluxe models:

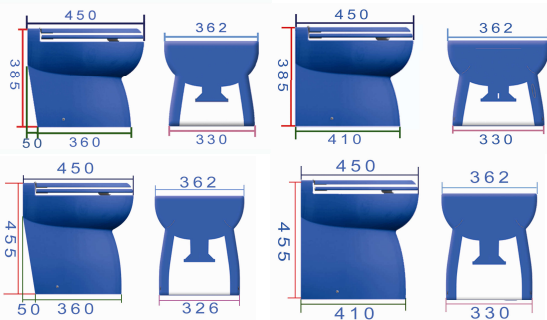

Laguna models:

Description	A	B	C	D	E	F
Laguna electric 12v.	340	411	359	248	316	190/205

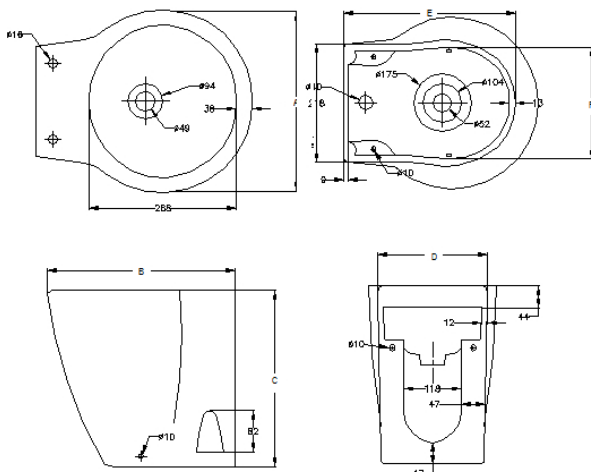

WATERWORKS

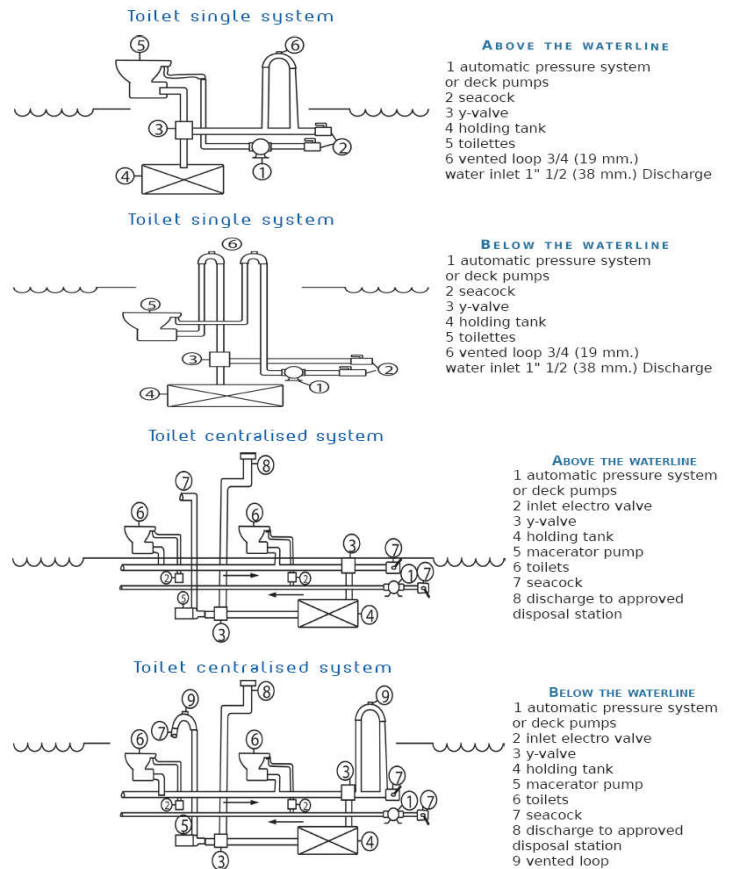

EXPLODING VIEW:

LAGUNA HYDRO VACUUM PUMP

A

DELUXE HYDRO VACUUM PUMP > 2011

B

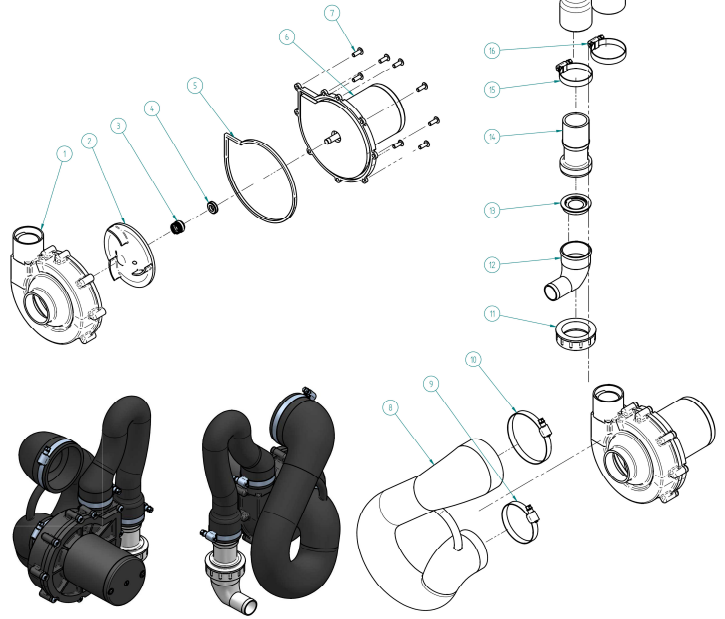
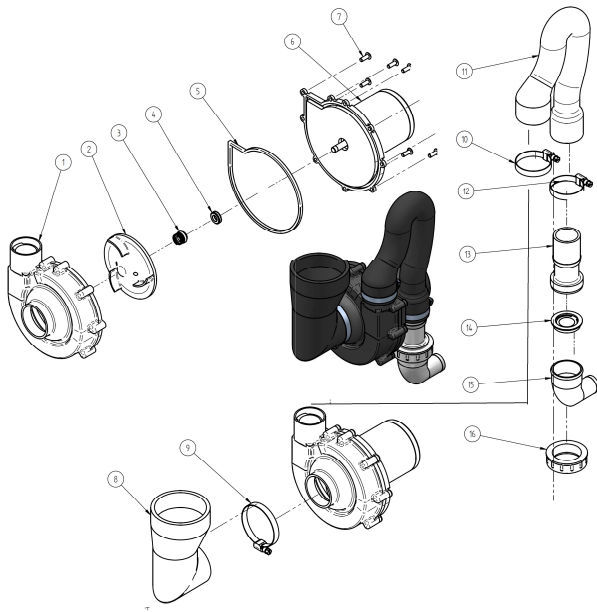

ITEM	DESCRIPTION	PART NUMBER	ITEM	DESCRIPTION	PART NUMBER	PART NUMBER
1	PUMP BODY	CD. 5500019008	8	HOSE	CD.5500019706	CD.5500019705 PICTURE A
2	IMPELLER		9-10	HOSE CLAMP		
3	MECHANICAL SEAL		11	NUT		
4	MECHANICAL SEAL STAT		12	CONNECTION		
5	PACKING		13	CHECK VALVE		
7	SCREW	CD. 60000019012-24 12V.-24V.	14	CONNECTION	CD.5500019706	CD.5500019706 PICTURE B
6	MOTOR		15-16	HOSE CLAMP		
			17	HOSE		

HYDRO VACUUM PUMP >2011

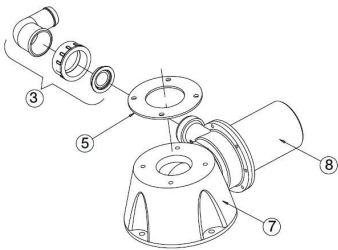

ITEM	DESCRIPTION	PART NUMBER
3	OUTLET ELBOW	5600000407J
5	GASKET BASE	GM000W9004 GM000WV008 (THIN CERAMIC FLANGE)
7	BASE GROUP	5600000405
8	MOTOR GROUP	60000002112 12V. 60000002124 24 V.

WARRANTY:

Products are guaranteed two years.

No warranty will be recognized in the following cases:

- if the bowl is broken
- if the fitted instructions regarding the electrical system and the directions for use have not been properly followed

Warning: the use of strong detergents to clean the toilet is forbidden, as these products stay on the inside of the system and burn the pump rubber seals through. Eventual traces found in the claimed goods will invalidate the warranty. TO TAKE ADVANTAGE OF WARRANTY, ALL ARTICLES MUST BE SENT BACK COMPLETE WITH ASSEMBLING INSTRUCTIONS AND EVIDENCE OF PURCHASE.

ATTENTION

THE BOWL IS ABLE TO DISCHARGE ONLY ORGANIC RESIDUALS AND TOILET PAPER BIODEGRADABLE