

Raymarine®



AXIOM™ XL

Installation instructions

English (en-US)
Date: 06-2018
Document number: 87344-1
© 2018 Raymarine UK Limited

Trademark and patents notice

Raymarine, Tacktick, Clear Pulse, Truzoom, SeaTalk, SeaTalk^{hs}, SeaTalk^{ng}, and Micronet, are registered or claimed trademarks of Raymarine Belgium.

FLIR, LightHouse, DownVision, SideVision, RealVision, Dragonfly, Quantum, Axiom, Instalert, Infrared Everywhere, The World's Sixth Sense and ClearCruise are registered or claimed trademarks of FLIR Systems, Inc.

All other trademarks, trade names, or company names referenced herein are used for identification only and are the property of their respective owners.

This product is protected by patents, design patents, patents pending, or design patents pending.

Fair Use Statement

You may print no more than three copies of this manual for your own use. You may not make any further copies or distribute or use the manual in any other way including without limitation exploiting the manual commercially or giving or selling copies to third parties.

Software updates



Check the Raymarine website for the latest software releases for your product.
www.raymarine.com/software

Product documentation



The latest versions of all English and translated documents are available to download in PDF format from the website: www.raymarine.com/manuals.
Please check the website to ensure you have the latest documentation.

Copyright ©2018 Raymarine UK Ltd. All rights reserved.

Contents

Chapter 1 Important information	9
Disclaimers	9
RF exposure	9
Compliance Statement (Part 15.19)	9
FCC Interference Statement (Part 15.105 (b))	10
Innovation, Science and Economic Development Canada (ISED)	10
Innovation, Sciences et Développement économique Canada (Français).....	10
Japanese approvals	10
MSIP Warning Statement for Radio Devices (Korea only)	11
Declaration of Conformity.....	11
Product disposal	11
Warranty registration.....	12
Technical accuracy.....	12
Chapter 2 Document and product information.....	13
2.1 Product documentation.....	14
User manuals Print Shop	14
LightHouse™ 3 MFD Operation instructions.....	14
2.2 Applicable products.....	15
Axiom™ XL Multifunction Displays.....	15
Additional components.....	15
2.3 Parts supplied	16
Chapter 3 Installation	17
3.1 Selecting a location.....	18
General location requirements	18
EMC installation guidelines.....	18
RF interference	19
Compass safe distance.....	19
GNSS (GPS) location requirements.....	19
Touchscreen location requirements.....	20
Wireless location requirements	20
Viewing angle considerations.....	20
Product dimensions	21
3.2 Mounting	22
Mounting options.....	22
Fitting the gasket tape	22
Mounting.....	23
Chapter 4 Connections.....	27
4.1 Connections overview (Axiom XL)	28
Connecting cables.....	29
4.2 Power connection	30

In-line fuse and thermal breaker ratings	30
Power distribution.....	30
Grounding — optional dedicated drain wire	34
4.3 NMEA 2000 (SeaTalkng [®]) connection	35
4.4 NMEA 0183 connection	36
4.5 Network connection.....	37
Cable suppression ferrites.....	37
Power over Ethernet (PoE).....	38
PoE connections	39
4.6 GA150 connection.....	40
4.7 Remote alarm connection	41
4.8 Accessory connection	42
4.9 HDMI in connection	43
4.10 HDMI out connection	44
4.11 Touch in connection.....	45
4.12 Touch out connection	46
4.13 Analog video (Video 1) connection	47
4.14 Analog video (Video 2) connection	48
Chapter 5 Maintaining your display	49
5.1 Service and maintenance.....	50
Routine equipment checks	50
5.2 Product cleaning	51
Cleaning the display case.....	51
Cleaning the display screen	51
Cleaning the sun cover.....	51
Chapter 6 Troubleshooting	53
6.1 Troubleshooting	54
6.2 Power up troubleshooting	55
Performing a power on reset — Axiom [™]	55
6.3 GNSS troubleshooting.....	56
6.4 Sonar troubleshooting.....	57
6.5 Wi-Fi troubleshooting	60
6.6 Touchscreen troubleshooting	63
6.7 Miscellaneous troubleshooting	64
Chapter 7 Technical support.....	65
7.1 Raymarine product support and servicing	66
Viewing product information	67
7.2 Learning resources	68
Chapter 8 Technical specification.....	69
8.1 Axiom XL technical specification	70
8.2 Internal GNSS (GPS / GLONASS) receiver specification	72

Chapter 9 Spares and accessories	73
9.1 AXIOM XL accessories	74
9.2 AXIOM XL spares	75
9.3 RayNet to RayNet cables and connectors	76
RayNet to RJ45 adapter cables	77
9.4 SeaTalkng [®] cables and accessories.....	78

Chapter 1: Important information



Warning: Product installation and operation

- This product must be installed and operated in accordance with the instructions provided. Failure to do so could result in personal injury, damage to your vessel and/or poor product performance.
- Raymarine recommends certified installation by a Raymarine approved installer. A certified installation qualifies for enhanced product warranty benefits. Contact your Raymarine dealer for further details, and refer to the separate warranty document packed with your product.



Warning: High voltage

This product contains high voltage. Adjustments require specialized service procedures and tools only available to qualified service technicians. There are no user serviceable parts or adjustments. The operator should never remove the cover or attempt to service the product.

Caution: Mounting surface requirements

This product is heavy. To prevent potential damage to the product and / or your vessel, observe the following BEFORE installing the product:

- Refer to the weight information provided in the technical specification for this product and ensure that the intended mounting surface is suitable for bearing the weight.
- If the mounting surface is not suitable for the product weight, you may need to reinforce the mounting surface.
- If in doubt, refer to a professional marine equipment installer for further guidance.

Disclaimers

Raymarine does not warrant that this product is error-free or that it is compatible with products manufactured by any person or entity other than Raymarine.

This product uses digital chart data, and electronic information from Global Navigation Satellite Systems (GNSS) which may contain errors. Raymarine does not warrant the accuracy of such information and you are advised that errors in such information may cause the product to malfunction. Raymarine is not responsible for damages or injuries caused by your use or inability to use the product, by the interaction of the product with products manufactured by others, or by errors in chart data or information utilized by the product and supplied by third parties.

This product supports electronic charts provided by third party suppliers which may be embedded or stored on memory card. Use of such charts is subject to the supplier's End-User Licence Agreement.

RF exposure

This equipment complies with FCC / IC RF exposure limits for general population / uncontrolled exposure. The wireless LAN / Bluetooth antenna is mounted behind the front facia of the display. This equipment should be installed and operated with a minimum distance of 1 cm (0.39 in) between the device and the body. This transmitter must not be co-located or operating in conjunction with any other antenna or transmitter, except in accordance with FCC multi-transmitter product procedures.

Compliance Statement (Part 15.19)

This device complies with Part 15 of the FCC Rules. Operation is subject to the following two conditions:

1. This device may not cause harmful interference.

2. This device must accept any interference received, including interference that may cause undesired operation.

FCC Interference Statement (Part 15.105 (b))

This equipment has been tested and found to comply with the limits for a Class B digital device, pursuant to Part 15 of the FCC Rules.

These limits are designed to provide reasonable protection against harmful interference in a residential installation. This equipment generates, uses, and can radiate radio frequency energy and, if not installed and used in accordance with the instructions, may cause harmful interference to radio communications. However, there is no guarantee that interference will not occur in a particular installation. If this equipment does cause harmful interference to radio or television reception, which can be determined by turning the equipment off and on, the user is encouraged to try to correct the interference by one of the following measures:

1. Reorient or relocate the receiving antenna.
2. Increase the separation between the equipment and receiver.
3. Connect the equipment into an outlet on a circuit different from that to which the receiver is connected.
4. Consult the dealer or an experienced radio / TV technician for help.

Innovation, Science and Economic Development Canada (ISED)

This device complies with License-exempt RSS standard(s).

Operation is subject to the following two conditions:

1. This device may not cause interference; and
2. This device must accept any interference, including interference that may cause undesired operation of the device.

This Class B digital apparatus complies with Canadian ICES-003.

Innovation, Sciences et Développement économique Canada (Français)

Cet appareil est conforme aux normes d'exemption de licence RSS.

Son fonctionnement est soumis aux deux conditions suivantes:

1. cet appareil ne doit pas causer d'interférence, et
2. cet appareil doit accepter toute interférence, notamment les interférences qui peuvent affecter son fonctionnement.

Cet appareil numérique de la classe B est conforme à la norme NMB-003 du Canada.

Japanese approvals

In the frequency band used for this device, campus radio stations (radio stations that require a license) and specified low power radio stations (radio stations that do not require license) for mobile identification and amateur radio stations (radio stations that require license) used in industries such as microwave ovens, scientific, medical equipment devices and production line of other factories are also being operated.

1. Before using this device, please make sure that campus radio stations and specified low power radio stations for mobile identification and amateur radio stations are not being operated nearby.
2. In case there is any case of harmful interference to campus radio stations for mobile identification caused by this device, please immediately change the frequency used or stop the transmission of radio waves and then consult about the measures to avoid interference (for example, the installation of partitions) through the contact information below.

3. Besides, when in trouble, such as when there is any case of harmful interference to specified low power radio stations for mobile identification or amateur radio stations caused by this device, please consult through the following contact information.

Contact information: Please contact your local authorized Raymarine dealer.

MSIP Warning Statement for Radio Devices (Korea only)

- 제작자 및 설치자는 해당 무선설비가 전파혼신 가능성이 있으므로 안전 인명과 관련된
- 서비스는 할 수 없음을 사용자 설명서 등을 통하여 운전자 및 사용자에게 충분히 알릴 것
- 법에 의해 전 방향 전파 발사 및 동일한 정보를 동시에 여러 곳으로 송신하는 점-대-다지점 서비스에의 사용은 금지되어 있습니다.

Declaration of Conformity

FLIR Belgium BVBA declares that the radio equipment types Axiom XL multifunction displays, part numbers E70399, E70400, E70401 and E70515 are in compliance with the Radio Equipment Directive 2014/53/EU.

The original Declaration of Conformity certificate may be viewed on the relevant product page at www.raymarine.com/manuals.

Product disposal

Dispose of this product in accordance with the WEEE Directive.

The Waste Electrical and Electronic Equipment (WEEE) Directive requires the recycling of waste electrical and electronic equipment which contains materials, components and substances that may be hazardous and present a risk to human health and the environment when WEEE is not handled correctly.



Equipment marked with the crossed-out wheeled bin symbol indicates that the equipment should not be disposed of in unsorted household waste.

Local authorities in many regions have established collection schemes under which residents can dispose of waste electrical and electronic equipment at a recycling center or other collection point.

For more information about suitable collection points for waste electrical and electronic equipment in your region, refer to the following table:

Region	Website	Region	Website
AT	www.araplus.at	IT	www.erp-recycling.org/it-it
BE	www.recupel.be	LT	www.eei.lt
BG	www.greentech.bg	LU	www.ecotrel.lu , https://aev.gouvernement.lu/fr.html
CY	www.electrocyclo-sis.com.cy	LV	www.lze.lv
CZ	www.retela.cz	MT	http://www.greenpak.com.mt
DE	www.earn-service.com	NL	www.wecycle.nl
DK	www.elretur.dk	PL	www.electro-system.pl
EE	www.elektronikaromu.ee	PT	www.amb3e.pt
ES	www.raee-asimelec.es	RO	www.ecotic.ro
FI	www.elker.fi	SE	www.el-kretsen.se

Region	Website	Region	Website
FR	www.ecologic-france.com , www.eco-systemes.fr	SI	www.zeos.si
GR	www.electrocycle.gr	SK	www.erp-recycling.sk
IE	www.weeeireland.ie	UK	www.wastecare.co.uk/compliance-services/weeecare

Warranty registration

To register your Raymarine product ownership, please visit www.raymarine.com and register online.

It is important that you register your product to receive full warranty benefits. Your unit package includes a bar code label indicating the serial number of the unit. You will need this serial number when registering your product online. You should retain the label for future reference.

Technical accuracy

To the best of our knowledge, the information in this document was correct at the time it was produced. However, Raymarine cannot accept liability for any inaccuracies or omissions it may contain. In addition, our policy of continuous product improvement may change specifications without notice. As a result, Raymarine cannot accept liability for any differences between the product and this document. Please check the Raymarine website (www.raymarine.com) to ensure you have the most up-to-date version(s) of the documentation for your product.

Chapter 2: Document and product information

Chapter contents

- [2.1 Product documentation on page 14](#)
- [2.2 Applicable products on page 15](#)
- [2.3 Parts supplied on page 16](#)

2.1 Product documentation

The following documentation is applicable to your product:

All documents are available to download as PDFs from www.raymarine.com

MFD Documentation

Description	Part number
Installation instructions (This document)	87344
Surface / Flush mounting template	<ul style="list-style-type: none">• Axiom™ XL 16 — 87339• Axiom™ XL 19 — 87340• Axiom™ XL 22 — 87356• Axiom™ XL 24 — 87341
LightHouse™ 3 Basic operation instructions	81369
LightHouse™ 3 Advanced operation instructions	81370

Accessory Documentation

Description	Part number
RCR-SDUSB Installation instructions	87317

User manuals Print Shop

Raymarine provides a Print Shop service, enabling you to purchase a high-quality, professionally-printed manual for your Raymarine product.

Printed manuals are ideal for keeping onboard your vessel, as a useful source of reference whenever you need assistance with your Raymarine product.

Visit <http://www.raymarine.co.uk/view/?id=5175> to order a printed manual, delivered directly to your door.

For further information about the Print Shop, please visit the Print Shop FAQ pages: <http://www.raymarine.co.uk/view/?id=5751>.

Note:

- Accepted methods of payment for printed manuals are credit cards and PayPal.
- Printed manuals can be shipped worldwide.
- Further manuals will be added to the Print Shop over the coming months for both new and legacy products.
- Raymarine user manuals are also available to download free-of-charge from the Raymarine website, in the popular PDF format. These PDF files can be viewed on a PC / laptop, tablet, smartphone, or on the latest generation of Raymarine multifunction displays.

LightHouse™ 3 MFD Operation instructions

For operation instructions for your MFD please refer to the LightHouse™ 3 MFD Operation instructions.



The Basic (81369) and Advanced (81370) LightHouse™ 3 Operation Instructions can be downloaded from the Raymarine website: www.raymarine.com/manuals

2.2 Applicable products

This document is applicable to the following products:

Axiom™ XL Multifunction Displays

Product number	Name	Description
E70399	Axiom™ XL 16	16" touchscreen multifunction display
E70400	Axiom™ XL 19	19" touchscreen multifunction display
E70515	Axiom™ XL 22	22" touchscreen multifunction display
E70401	Axiom™ XL 24	24" touchscreen multifunction display

Additional components

The following additional components may be required.

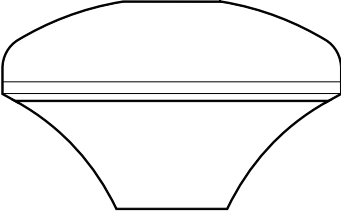
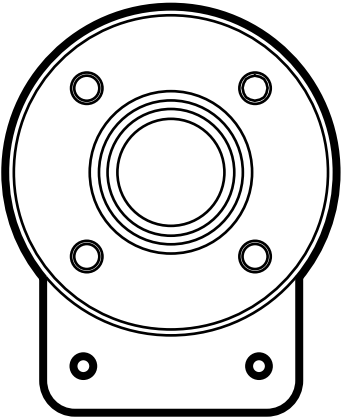
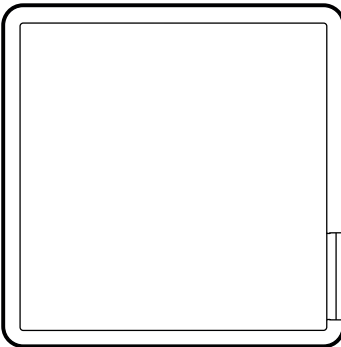
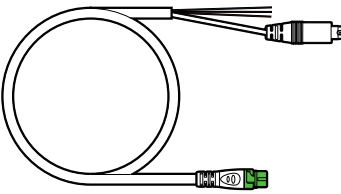
	Part number	Description
	A80288	GA150 passive GNSS (GPS) antenna
	E26033	Remote MFD alarm buzzer (Honk).
	A80440	RCR-SDUSB Remote USB and SD card reader.
	A80235	Honk / alarm and analog video input cable.

The above accessories are included in the Axiom XL accessory pack: T70431.

2.3 Parts supplied

The following parts are supplied with your product. Please check your box contents before proceeding with the installation.

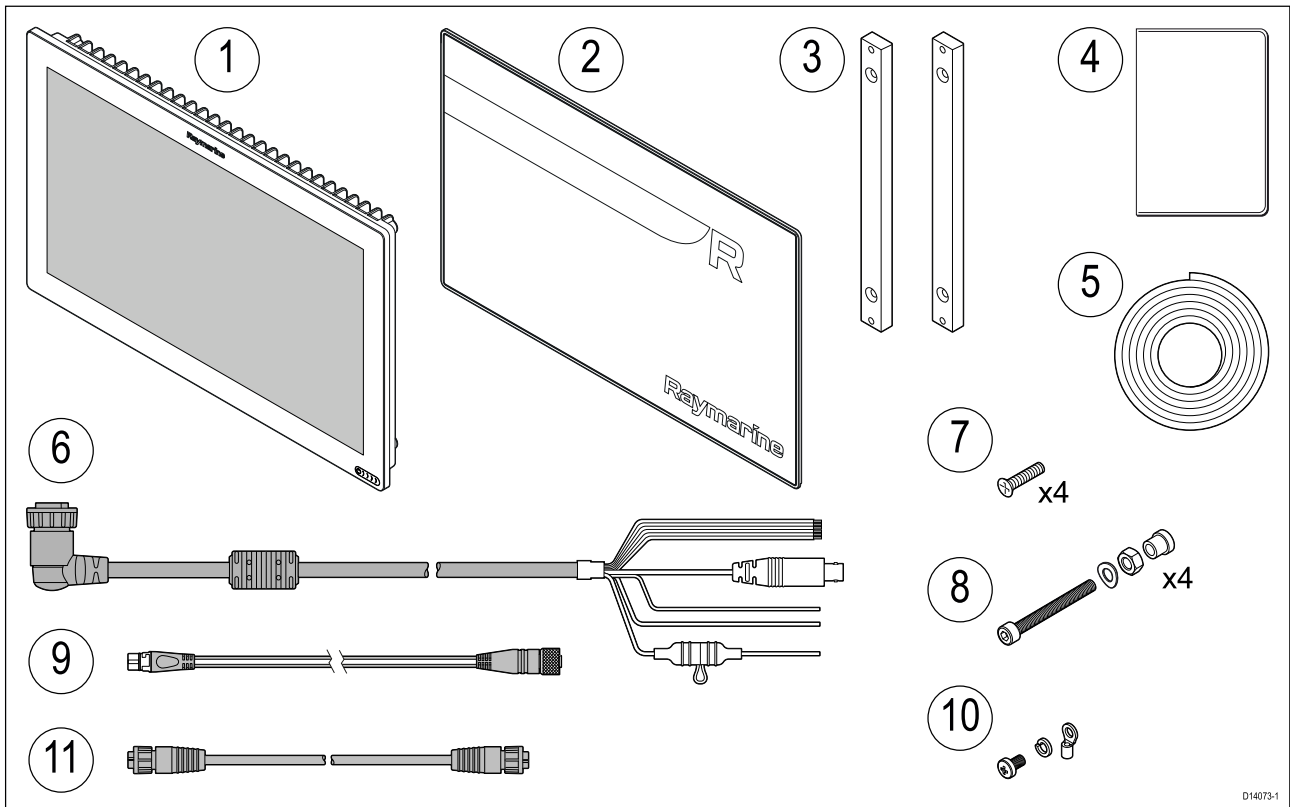

1. Axiom™ XL MFD.
2. Suncover (Silicone).
3. Rear mounting bar x2.
4. Documentation pack.
5. Mounting gasket tape.
6. Power/Video/NMEA 0183 cable 1.5 m (4.92 ft) right-angled.
7. Mounting bar fixings x4 (M5 x 20 pozi countersunk).
8. Mounting fixings x4 (Including M5 x 35 Bolts, M5 wavy washers, M5 nuts and mounting feet).
9. SeaTalkng™ to DeviceNet 1 m (3.3 ft) adaptor cable.
10. M3x5 screw, M3 spring washer and M3 crimp terminal (for optional grounding connection).
11. RayNet 2 m (6.6 ft) network cable.

Chapter 3: Installation

Chapter contents

- [3.1 Selecting a location on page 18](#)
- [3.2 Mounting on page 22](#)

3.1 Selecting a location

Caution: Mounting surface requirements

This product is heavy. To prevent potential damage to the product and / or your vessel, observe the following BEFORE installing the product:

- Refer to the weight information provided in the technical specification for this product and ensure that the intended mounting surface is suitable for bearing the weight.
- If the mounting surface is not suitable for the product weight, you may need to reinforce the mounting surface.
- If in doubt, refer to a professional marine equipment installer for further guidance.



Warning: Switch off power supply

Ensure the vessel's power supply is switched OFF before starting to install this product. Do NOT connect or disconnect equipment with the power switched on, unless instructed in this document.



Warning: Potential ignition source

This product is NOT approved for use in hazardous/flammable atmospheres. Do NOT install in a hazardous/flammable atmosphere (such as in an engine room or near fuel tanks).

General location requirements

When selecting a location for your product it is important to consider a number of factors.

Key factors which can affect product performance are:

- **Ventilation** — To ensure adequate airflow:
 - Ensure that product is mounted in a compartment of suitable size.
 - Ensure that ventilation holes are not obstructed. Allow adequate separation of all equipment.Any specific requirements for each system component are provided later in this chapter.
- **Mounting surface** — Ensure product is adequately supported on a secure surface. Do not mount units or cut holes in places which may damage the structure of the vessel.
- **Cabling** — Ensure the product is mounted in a location which allows proper routing, support and connection of cables:
 - Minimum bend radius of 100 mm (3.94 in) unless otherwise stated.
 - Use cable clips to prevent stress on connectors.
 - If your installation requires multiple ferrites to be added to a cable then additional cable clips should be used to ensure the extra weight of the cable is supported.
- **Water ingress** — The product is suitable for mounting both above and below decks. Although the unit is waterproof, it is good practice to locate it in a protected area away from prolonged and direct exposure to rain and salt spray.
- **Electrical interference** — Select a location that is far enough away from devices that may cause interference, such as motors, generators and radio transmitters / receivers.
- **Power supply** — Select a location that is as close as possible to the vessel's DC power source. This will help to keep cable runs to a minimum.

EMC installation guidelines

Raymarine equipment and accessories conform to the appropriate Electromagnetic Compatibility (EMC) regulations, to minimize electromagnetic interference between equipment and minimize the effect such interference could have on the performance of your system

Correct installation is required to ensure that EMC performance is not compromised.

Note: In areas of extreme EMC interference, some slight interference may be noticed on the product. Where this occurs the product and the source of the interference should be separated by a greater distance.

For **optimum** EMC performance we recommend that wherever possible:

- Raymarine equipment and cables connected to it are:
 - At least 1 m (3 ft) from any equipment transmitting or cables carrying radio signals e.g. VHF radios, cables and antennas. In the case of SSB radios, the distance should be increased to 7 ft (2 m).
 - More than 2 m (7 ft) from the path of a radar beam. A radar beam can normally be assumed to spread 20 degrees above and below the radiating element.
- The product is supplied from a separate battery from that used for engine start. This is important to prevent erratic behavior and data loss which can occur if the engine start does not have a separate battery.
- Raymarine specified cables are used.
- Cables are not cut or extended, unless doing so is detailed in the installation manual.

Note: Where constraints on the installation prevent any of the above recommendations, always ensure the maximum possible separation between different items of electrical equipment, to provide the best conditions for EMC performance throughout the installation

RF interference

Certain third-party external electrical equipment can cause Radio Frequency (RF) interference with GNSS (GPS), AIS or VHF devices, if the external equipment is not adequately insulated and emits excessive levels of electromagnetic interference (EMI).

Some common examples of such external equipment include LED spot or strip lights, and terrestrial TV tuners.

To minimize interference from such equipment:

- Keep it as far away from GNSS (GPS), AIS or VHF devices as possible.
- Ensure that any power cables for external equipment are not entangled with the power or data cables for these devices.
- Consider fitting one or more high frequency suppression ferrites to the EMI-emitting device. The ferrite(s) should be rated to be effective in the range 100 MHz to 2.5 GHz, and should be fitted to the power cable and any other cables exiting the EMI-emitting device, as close as possible to the position where the cable exits the device.

Compass safe distance

To prevent potential interference with the vessel's magnetic compasses, ensure an adequate distance is maintained from the product.

When choosing a suitable location for the product you should aim to maintain the maximum possible distance from any compasses. Typically this distance should be at least 1 m (3 ft) in all directions. However for some smaller vessels it may not be possible to locate the product this far away from a compass. In this situation, when choosing the installation location for your product, ensure that the compass is not affected by the product when it is in a powered state.

GNSS (GPS) location requirements

Your product includes a built-in GNSS (GPS) receiver that, in order to obtain a position fix, requires connection of an external passive antenna, such as the GA150 antenna.

Ensure you follow the location requirements specified in your external antenna's installation instructions.

Touchscreen location requirements

Note:

Touchscreen performance can be affected by the installation environment, specifically Touchscreen displays installed above decks, where it will be open to the elements may exhibit the following:

- Hot Touchscreen temperature — If the display is mounted where it will be exposed to prolonged periods of direct sunlight, the touchscreen may become hot.
- Erroneous Touchscreen performance — Exposure to prolonged rain and / or water wash over may cause the display to respond to 'false touches', caused by the rain/water hitting the screen.

If, due to the required installation location, exposure to these elements is anticipated then it is recommended that you consider:

- Installing a remote keypad such as the RMK-10 and operating the display remotely — Touch-only displays.
- Locking the Touchscreen and using the physical buttons instead — HybridTouch displays.
- Attaching a third-party 'display hood accessory' to reduce direct sunlight exposure and the volume of water that the display is exposed to.

Wireless location requirements

A number of factors can influence wireless performance, it is important to ensure you test the connection performance, at the desired location before installing wireless enabled products.

Distance

The distance between wireless products should always be kept to a minimum. Do not exceed the maximum stated range of your wireless product (Maximum range will vary for each device).

Wireless performance degrades over distance, so products farther away will receive less network bandwidth. Products installed close to their maximum wireless range may experience slow connection speeds, signal drop outs or not being able to connect at all.

Line of sight

For best results the wireless product should have a clear, direct line of sight to the product it will be connected to. Any physical obstructions can degrade or even block the wireless signal.

The construction of your vessel can also have an impact on wireless performance. For example, metal structural bulkheads and roofing will reduce and in certain situations, block the wireless signal.

If the wireless signal passes through a bulkhead containing power cables this can also degrade wireless performance.

Reflective surfaces such as metal surfaces, some types of glass and even mirrors can drastically effect performance or even block the wireless signal.

Interference and other equipment

Wireless products should be installed at least 1m (3 ft) away from:

- Other wireless enabled products.
- Transmitting products that send wireless signals in the same frequency range.
- Other electrical, electronic or electromagnetic equipment that may generate interference.

Interference from other peoples wireless devices can also cause interference with your products. You can use a third party wireless analyzer tool / smartphone app to assess the best wireless channel (channel not in use or used by least amount of devices) for you to use.

Viewing angle considerations

As display contrast and color are affected by the viewing angle, It is recommended that you temporarily power up the display, prior to installation, to enable you to best judge which location provides the optimum viewing angle.

Refer to [Chapter 8 Technical specification](#) for viewing angles for your product.

Product dimensions

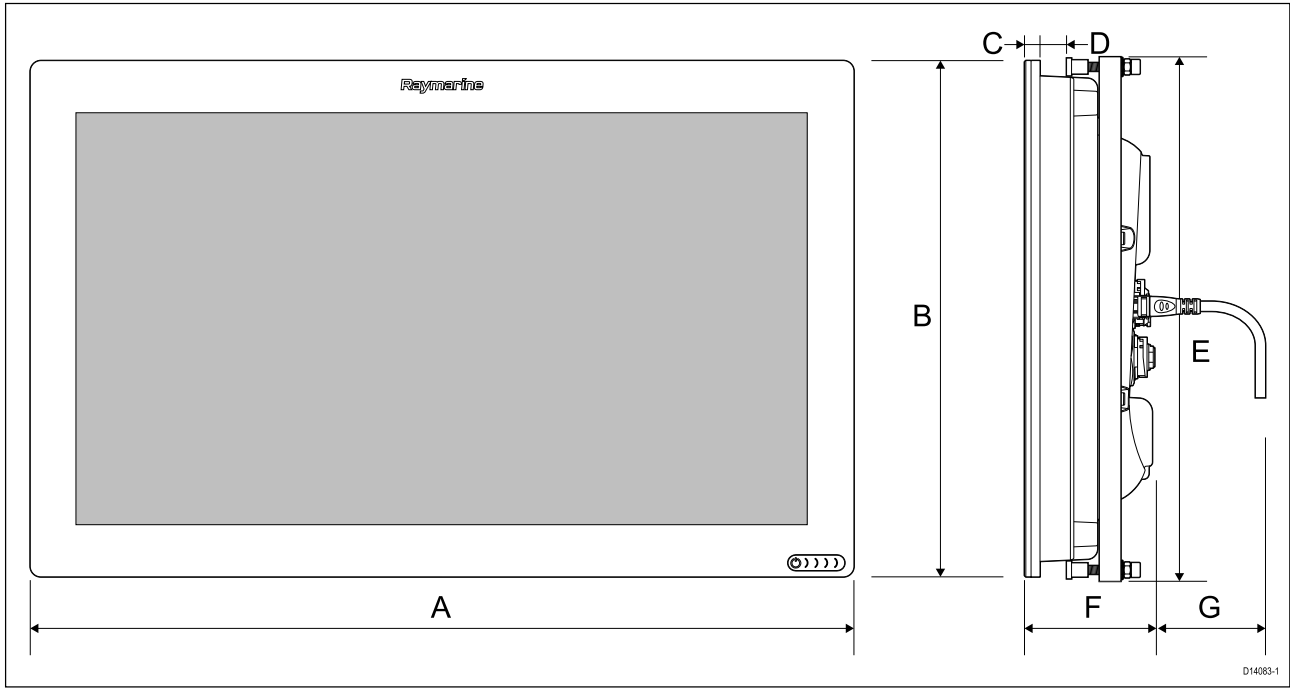

	XL 16	XL 19	XL 22	XL 24
A	394.9 mm (15.55 in)	461.78 mm (18.18 in)	533.56 mm (21.00 in)	578.40 mm (22.77 in)
B	248.22 mm (9.77 in)	289.44 mm (11.40 in)	326.33 mm (12.85 in)	386.84 mm (15.23 in)
C	9 mm (0.35 in)			
D	Minimum: 6 mm (0.24 in) Maximum 19 mm (0.75 in)			
E	253 mm (9.96 in)	294 mm (11.57 in)	331 mm (13.03 in)	392 mm (15.43 in)
F	73.96 mm (2.91 in)	73.95 mm (2.91 in)	79.75 mm (3.14 in)	76.36 mm (3.01 in)
G	101 mm (3.98 in)			

Note:

- Dimension D above shows the minimum and maximum thickness of the mounting surface when surface mounting the MFD.
- Dimensions C+D shows the minimum and maximum mounting surface thickness when flush mounting the MFD.

3.2 Mounting

Mounting options

Axiom XL MFDs can be surface or flush mounted.

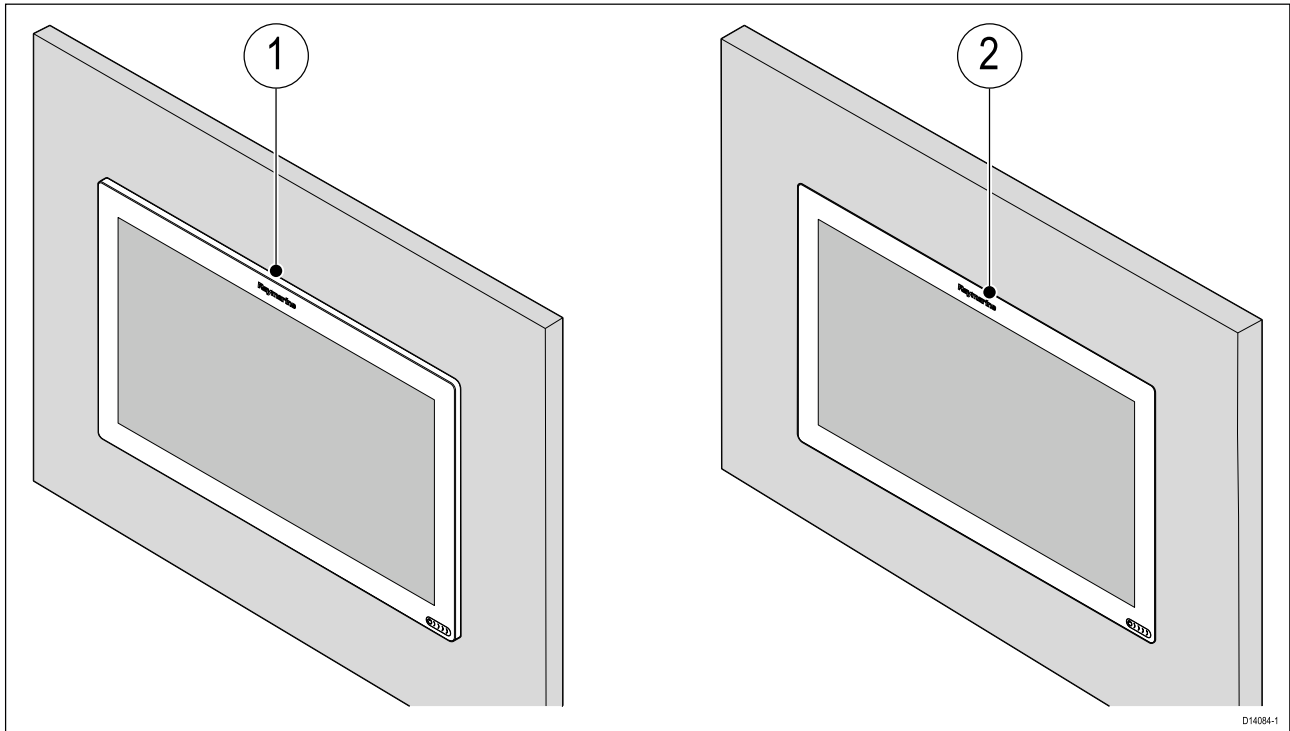

1. Surface mount
2. Flush mount

Caution: 2 person installation required

To prevent product damage and personal injury your product requires 2-person installation.

Fitting the gasket tape

Before fitting the MFD you must fit the mounting gasket tape to the rear of the MFD.

The gasket tape is affixed to the flange around the edge on the rear of the MFD.

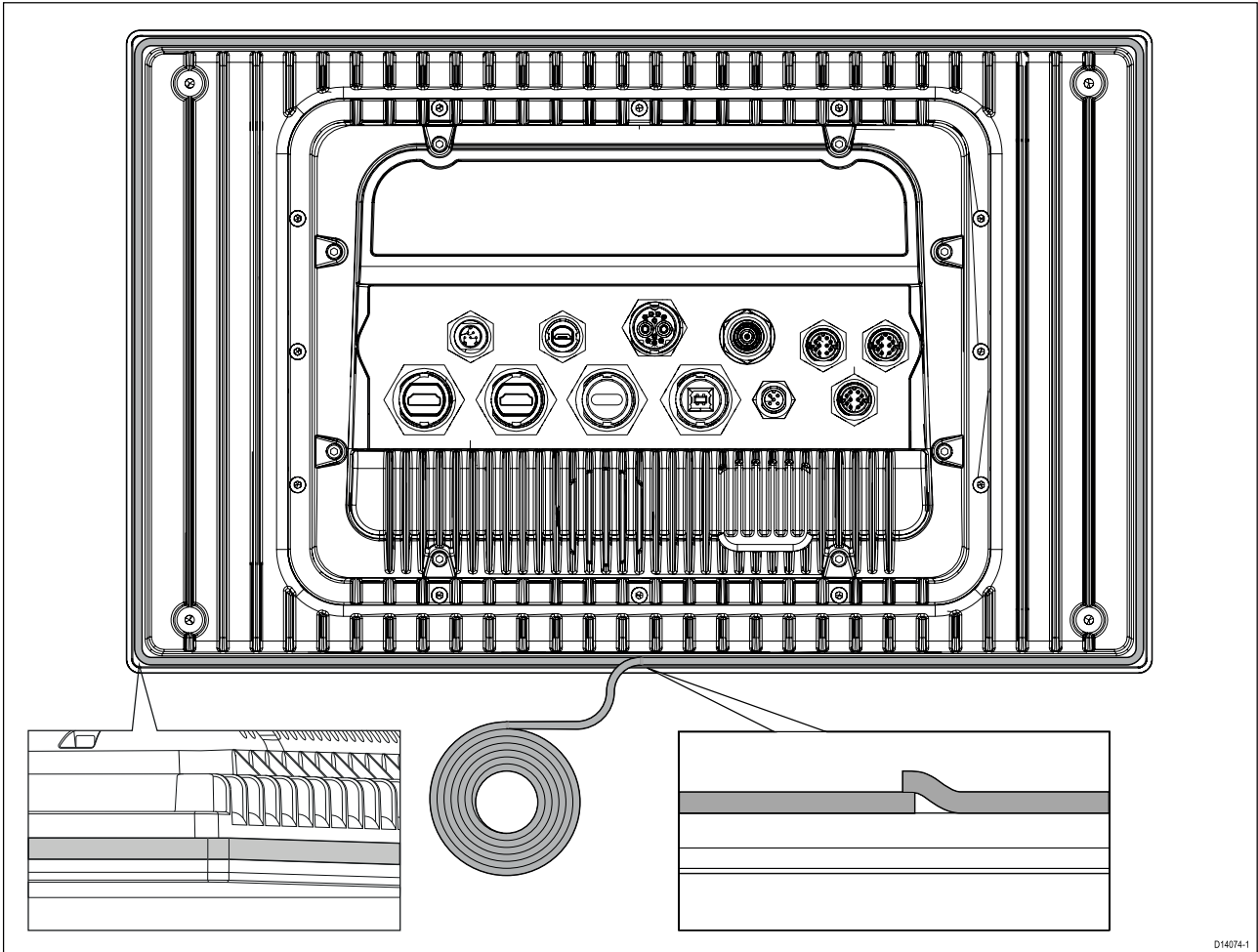

1. Starting at the bottom centre, affix the gasket tape to the MFD.
2. Remove the paper backing from the tape before going around the corners, ensuring that the tape remains tight and no air gap exists between MFD and tape.
3. When you reach the end, leave a small overlap to ensure that no gap exists between the ends of the gasket when it is compressed.

Note: The supplied gasket tape provides a seal between the unit and a suitably flat and stiff mounting surface or binnacle. The gasket should be used in all installations. It may also be necessary to use a marine-grade sealant if the mounting surface or binnacle is not entirely flat and stiff or has a rough surface finish.

Mounting

Axiom XL MFDs can be surface or flush mounted from the rear of the mounting surface.

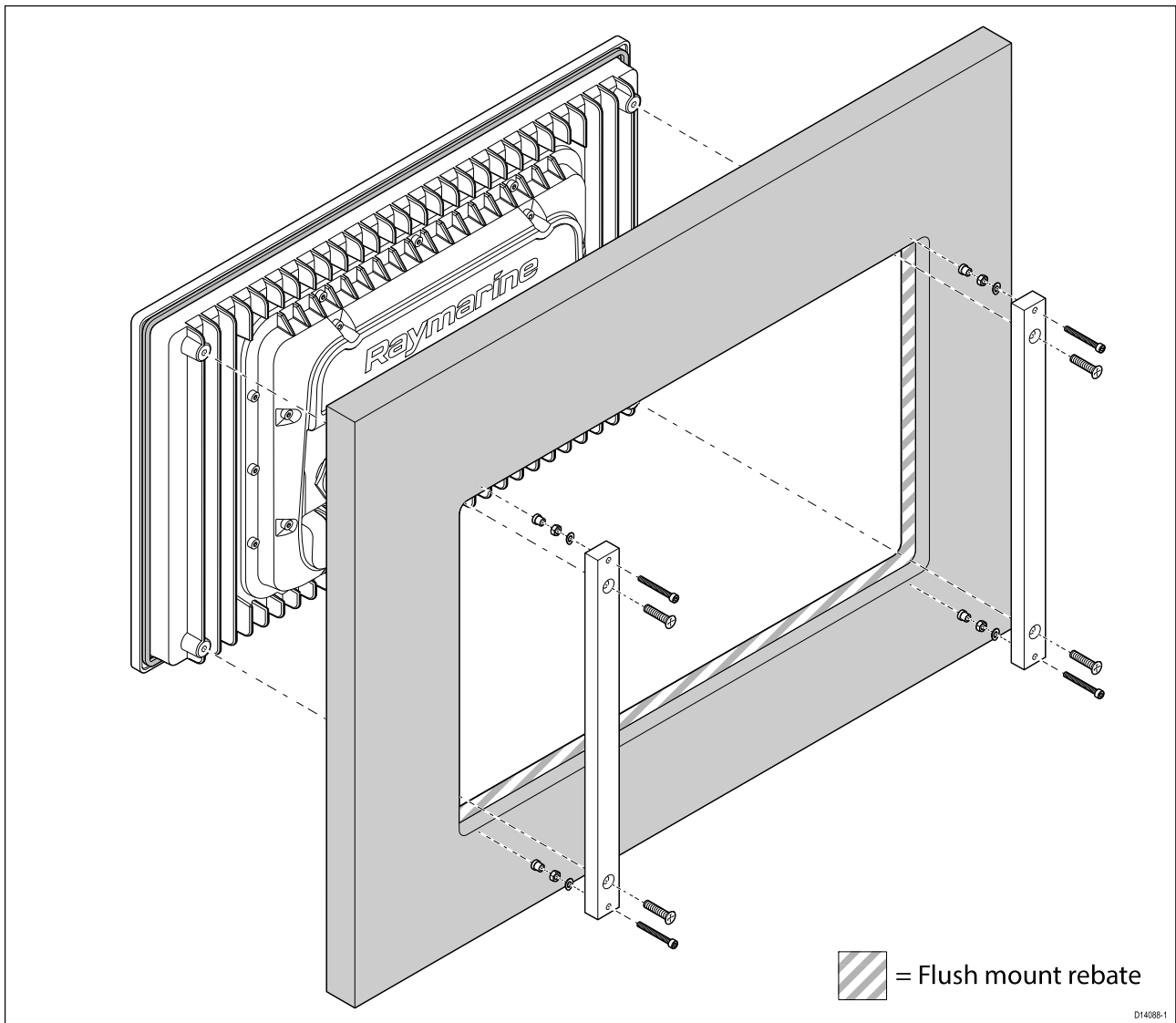

1. Using the supplied mounting template as a guide, cut the cut-out hole in the mounting surface. If you are flush mounting also follow the rebate information on the mounting template.
2. With one person holding the MFD in place, the second person should affix the mounting bars to the back of the MFD using the supplied M5x20 countersunk screws in 4 locations.
3. Secure the MFD using the provided mounting fixings (M5 bolt, wavy washer, nut and foot. In 4 locations).

Depending on the thickness of the mounting surface the washer and lock nut may be located:

1. between the mounting bracket and mounting feet (as shown in (1) and (2) below, or;
2. after the mounting bracket as shown in (3) and (4) below.

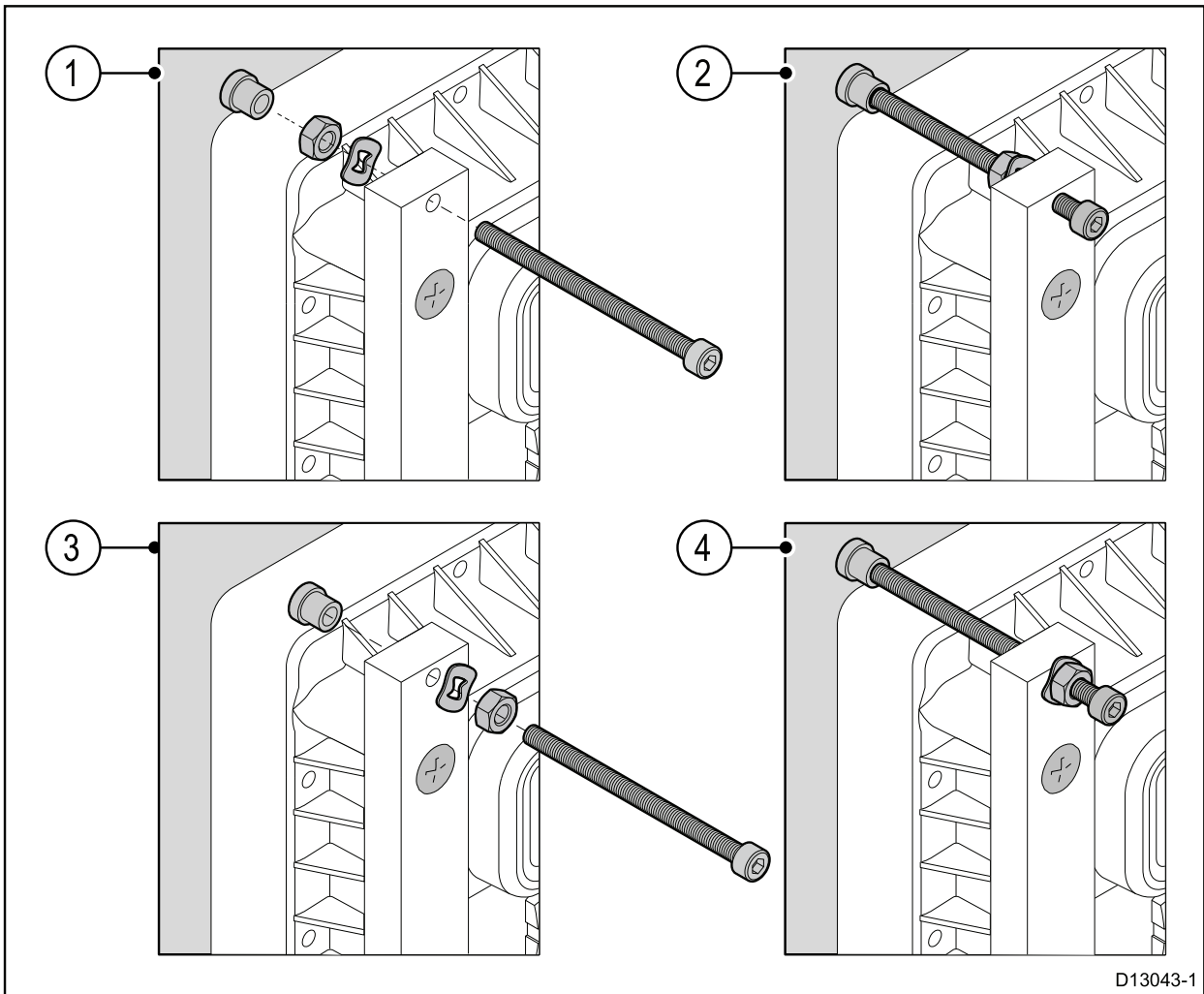

4. Using a 4 mm Hex (Allen) key, tighten the mounting bar bolts so that the feet are tight against the rear of the mounting surface.
5. Using a 8 mm wrench or adjustable wrench, tighten the nut against the washer and the mounting bar to lock in position.

The nut should be tightened sufficiently to securely hold the MFD in position.

Important:

In above decks, flush mount installations, marine-grade silicone should be used to seal the gap between the edge of the mounting surface and the edge of the MFD.

Chapter 4: Connections

Chapter contents

- 4.1 Connections overview (Axiom XL) on page 28
- 4.2 Power connection on page 30
- 4.3 NMEA 2000 (SeaTalkng[®]) connection on page 35
- 4.4 NMEA 0183 connection on page 36
- 4.5 Network connection on page 37
- 4.6 GA150 connection on page 40
- 4.7 Remote alarm connection on page 41
- 4.8 Accessory connection on page 42
- 4.9 HDMI in connection on page 43
- 4.10 HDMI out connection on page 44
- 4.11 Touch in connection on page 45
- 4.12 Touch out connection on page 46
- 4.13 Analog video (Video 1) connection on page 47
- 4.14 Analog video (Video 2) connection on page 48

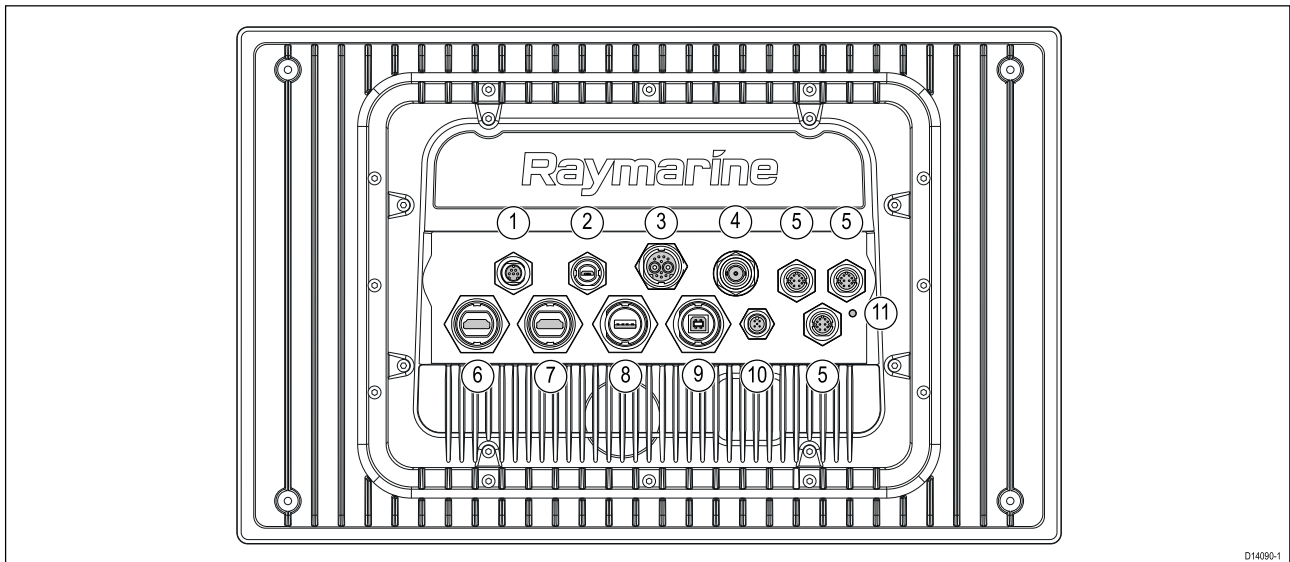

4.1 Connections overview (Axiom XL)

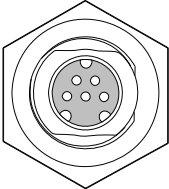
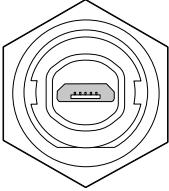
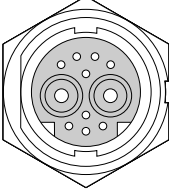
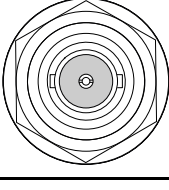
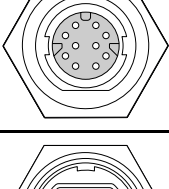
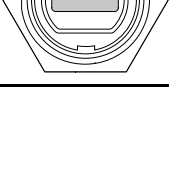

D14090-1

Axiom Pro connection options

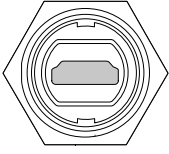
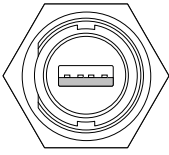
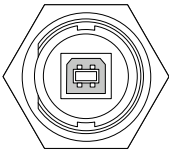
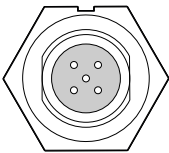
Item	Connector	Connects to:	Suitable cables	
1		Alarm Video 1 <ul style="list-style-type: none"> Remote MFD alarm buzzer (Honk) (E26033) Analog video feed 	Alarm/Video cable (A80235)	
2		Accessory <ul style="list-style-type: none"> RCR-SDUSB remote card reader RCR-2 remote card reader 	RCR-SDUSB/RCR-2's fitted cable	
3		Power / Video 2 / NMEA 0183	12/24 V DC power supply / Video input / NMEA 0183	Power/Video/0183 cable
4		GA150	GA150 antenna	GA150's fitted cable
5		Network (x 3)	RayNet network or PoE device	RayNet cable with female connector
6		HDMI In	HDMI video source	HDMI cable (A80219)

Item	Connector		Connects to:	Suitable cables
7		HDMI Out	Display	HDMI cable (A80219)
8		Touch In	Display that supports touchscreen output	USB A to USB B cable (A80578)
9		Touch Out	Touchscreen compatible PC/MFD	USB B to USB A cable (A80579)
10		NMEA 2000	<ul style="list-style-type: none"> • SeaTalkng[®] backbone • NMEA 2000 backbone 	<ul style="list-style-type: none"> • SeaTalkng[®] to DeviceNet adaptor cable • DeviceNet cables
11		Optional grounding point	Vessel RF ground, or negative battery terminal	Refer to Grounding — optional dedicated drain wire section for details

The **HDMI in** and **Video 2** analog connections share hardware internal to the MFD and so cannot be used at the same time. If devices are connected to both connections then the **HDMI in** connection will take priority.

Refer to [Chapter 9 Spares and Accessories](#) for available cables.

Connecting cables

Follow the steps below to connect the cable(s) to your product.

1. Ensure that the vessel's power supply is switched off.
2. Ensure that the device being connected has been installed in accordance with the installation instructions supplied with that device.
3. Ensuring correct orientation, push cable connectors fully onto the corresponding connectors.
4. If applicable, engage any locking mechanism to ensure a secure connection.
5. Ensure any bare ended wire connections are suitably insulated to prevent corrosion due to water ingress.

4.2 Power connection

The power cable must be connected to a 12 or 24 V dc power supply; this can be achieved by connecting directly to a battery, or via a distribution panel. The product is protected against reverse polarity.

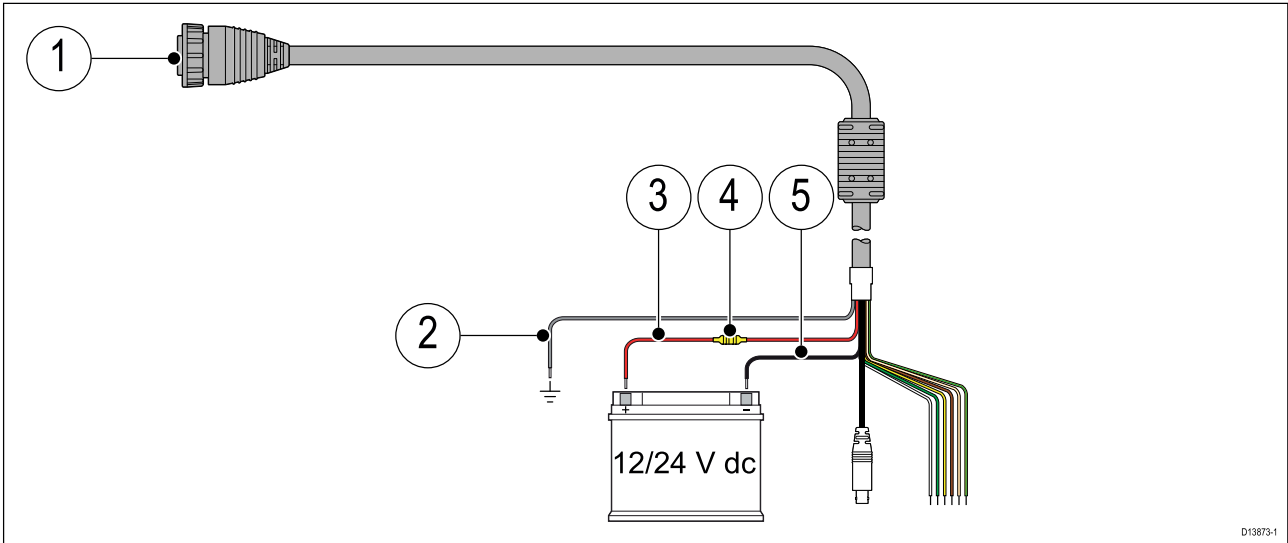

Note:

- Axiom Pro MFDs are supplied with a power cable that has a straight connector as shown above.
- Axiom XL MFDs are supplied with a power cable that has a right-angled connector.

1. Power/Video/NMEA 0183 cable connects to the rear of the MFD.
2. Ground wire connects to RF ground point. If no ground point is available connect to the battery negative (-) terminal.
3. Positive (Red) wire connects to battery positive (+) terminal.
4. Fuse.
5. Negative wire connects to the battery's negative (-) terminal.

In-line fuse and thermal breaker ratings

The following in-line fuse and thermal breaker ratings apply to your product:

In-line fuse rating	Thermal breaker rating
15 A	15 A (if only connecting one device)

Note:

- The suitable fuse rating for the thermal breaker is dependent on the number of devices you are connecting. If in doubt consult an authorized Raymarine dealer.
- Your product's power cable may have a fitted in-line fuse. If not, you must fit an in-line fuse to the positive wire of your product's power connection.

Caution: Power supply protection

When installing this product ensure the power source is adequately protected by means of a suitably-rated fuse or automatic circuit breaker.

Power distribution

Recommendations and best practice.

- The product is supplied with a power cable, either as a separate item or a captive cable permanently attached to the product. Only use the power cable supplied with the product. Do NOT use a power cable designed for, or supplied with, a different product.
- Refer to the *Power connection* section for more information on how to identify the wires in your product's power cable, and where to connect them.

- See below for more information on implementation for some common power distribution scenarios.

Important:

When planning and wiring, take into consideration other products in your system, some of which (e.g. sonar modules) may place large power demand peaks on the vessel's electrical system, which may impact the voltage available to other products during the peaks.

Note:

The information provided below is for guidance only, to help protect your product. It covers common vessel power arrangements, but does NOT cover every scenario. If you are unsure how to provide the correct level of protection, please consult an authorized Raymarine dealer or a suitably qualified professional marine electrician.

Implementation – direct connection to battery

- The power cable supplied with your product may be connected directly to the vessel's battery, via a suitably rated fuse or breaker.
- The power cable supplied with your product may NOT include a separate drain wire. If this is the case, only the power cable's red and black wires need to be connected.
- If the supplied power cable is NOT fitted with an inline fuse, you MUST fit a suitably rated fuse or breaker between the red wire and the battery's positive terminal.
- Refer to the inline fuse ratings provided in the product's documentation.
- If you need to extend the length of the power cable supplied with your product, ensure you observe the dedicated *Power cable extensions* advice provided in the product's documentation.

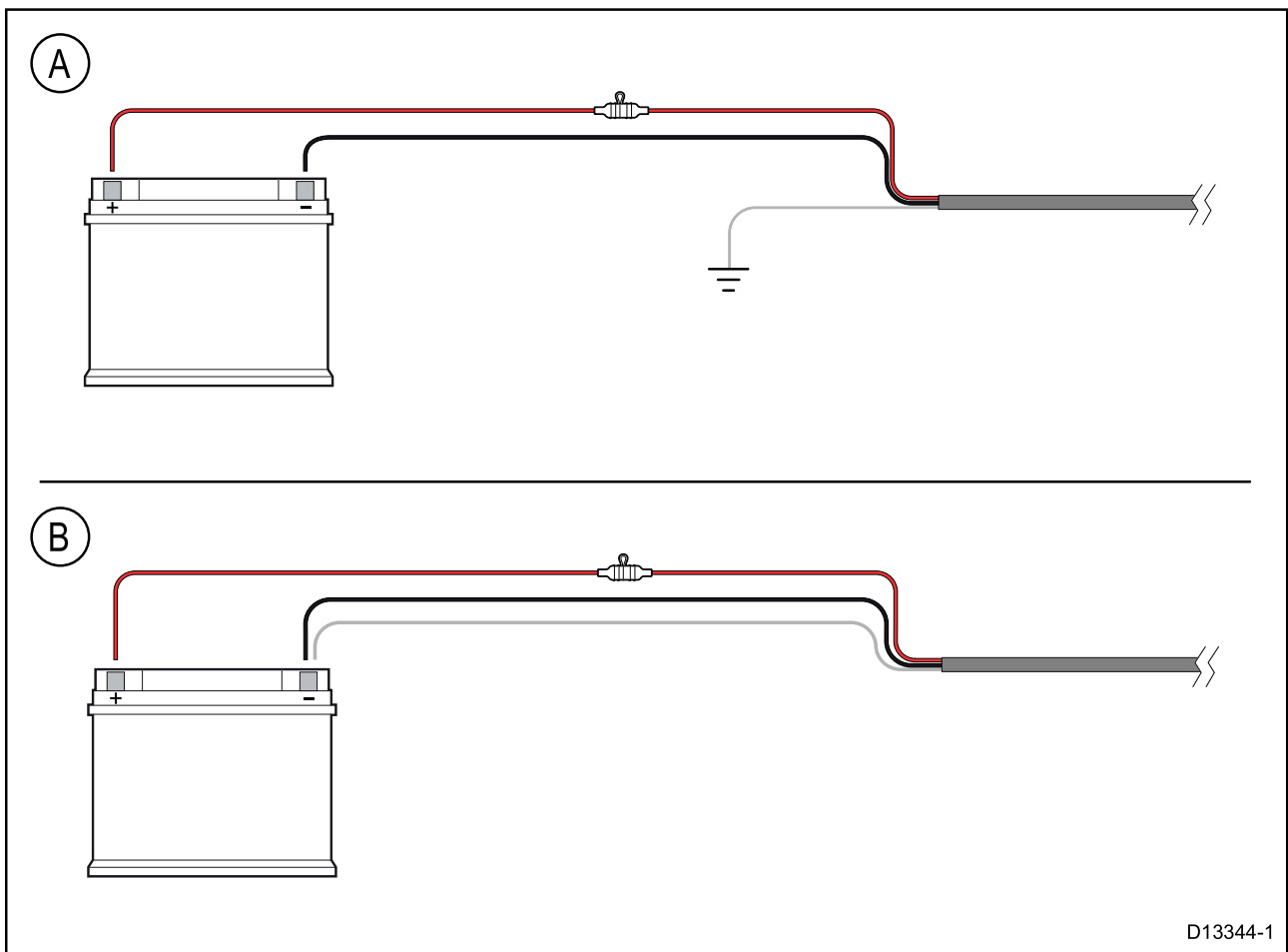

A	Battery connection scenario A: suitable for a vessel with a common RF ground point. In this scenario, if your product's power cable is supplied with a separate drain wire then it should be connected to the vessel's common ground point.
B	Battery connection scenario B: suitable for a vessel without a common grounding point. In this case, if your product's power cable is supplied with a separate drain wire then it should be connected directly to the battery's negative terminal.

Implementation – connection to distribution panel

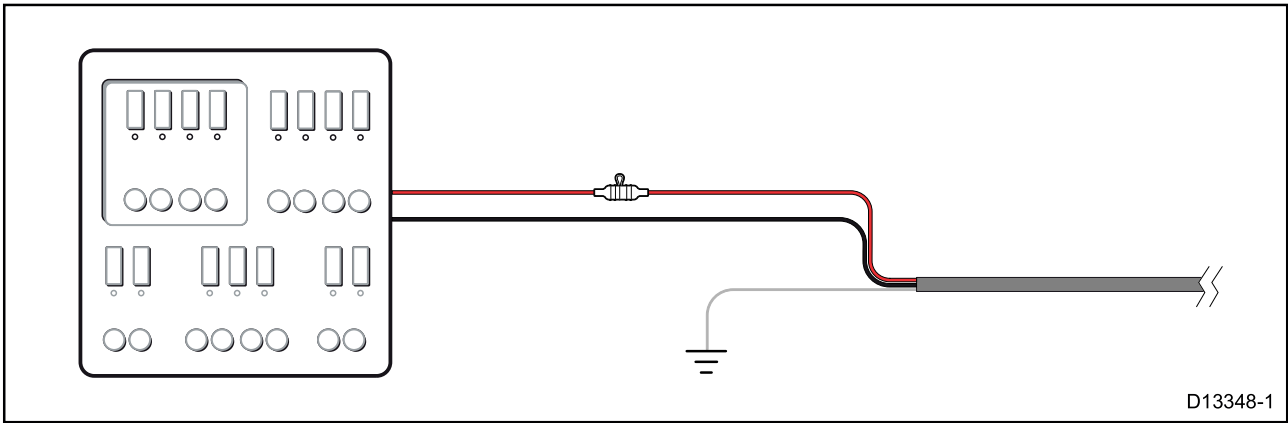

- Alternatively, the supplied power cable may be connected to a suitable breaker or switch on the vessel's distribution panel or factory-fitted power distribution point.
- The distribution point should be fed from the vessel's primary power source by 8 AWG (8.36 mm²) cable.
- Ideally, all equipment should be wired to individual suitably-rated thermal breakers or fuses, with appropriate circuit protection. Where this is not possible and more than 1 item of equipment shares a breaker, use individual in-line fuses for each power circuit to provide the necessary protection.

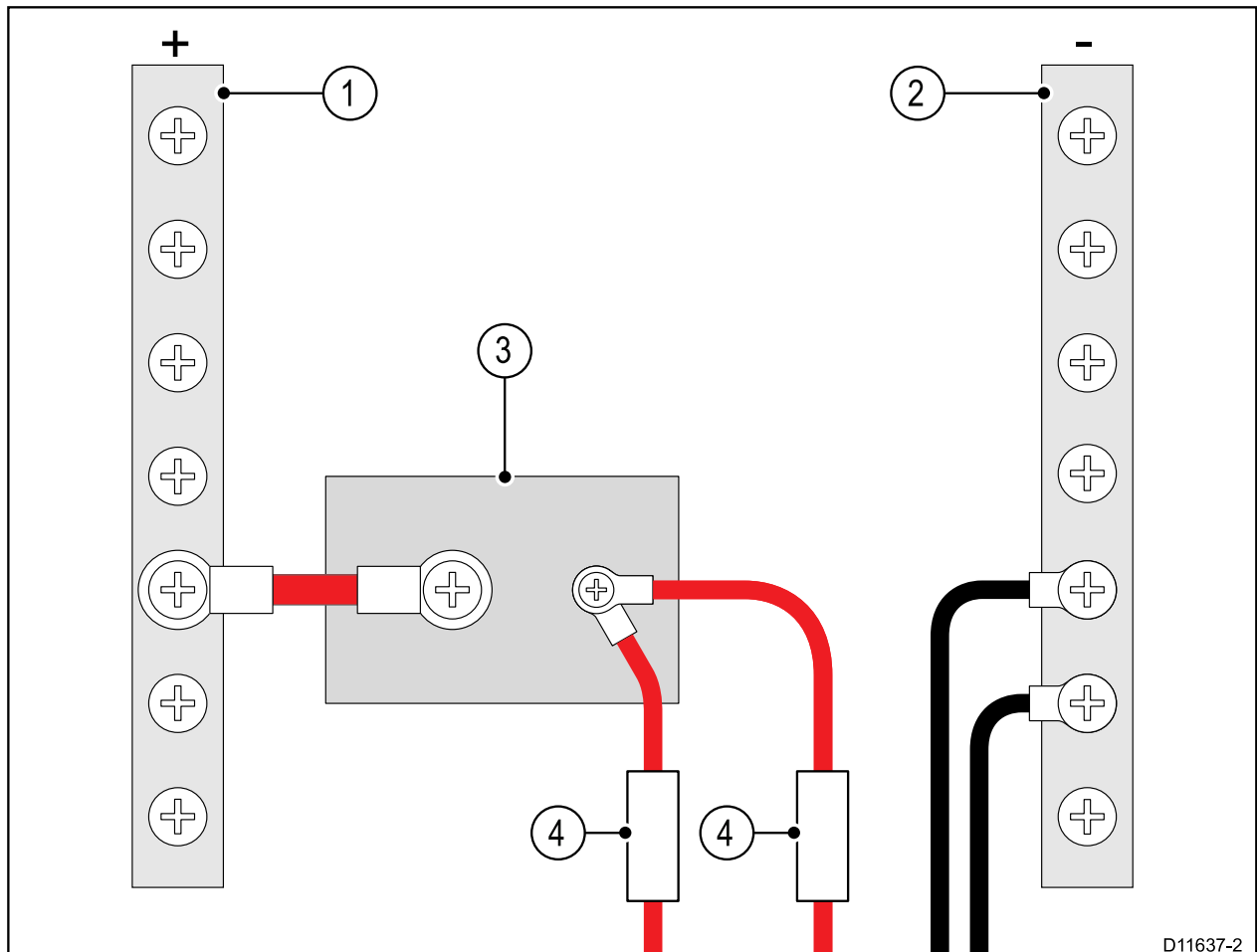

1	Positive (+) bar
2	Negative (-) bar
3	Circuit breaker
4	Fuse

- In all cases, observe the recommended breaker / fuse ratings provided in the product's documentation.

Important:

Be aware that the suitable fuse rating for the thermal breaker or fuse is dependent on the number of devices you are connecting.

Power cable extension

If you need to extend the length of the power cable supplied with your product, ensure you observe the following advice:

- The power cable for each unit in your system should be run as a separate, single length of 2-wire cable from the unit to the vessel's battery or distribution panel.
- For power cable extensions, a **minimum** wire gauge of 16 AWG (1.31 mm²) is recommended. For cable runs longer than 15 meters, you may need to consider a thicker wire gauge (e.g. 14 AWG (2.08 mm²), or 12 AWG (3.31 mm²)).
- An important requirement for all lengths of power cable (including any extension) is to ensure that there is a continuous **minimum** voltage at the product's power connector of 10.8 V dc, with a fully flat battery at 11 V dc.

Important: Be aware that some products in your system (such as sonar modules) can create voltage peaks at certain times, which may impact the voltage available to other products during the peaks.

Grounding

Ensure that you observe any separate grounding advice provided in the product's documentation.

More information

It is recommended that best practice is observed in all vessel electrical installations, as detailed in the following standards:

- BMEA Code of Practice for Electrical and Electronic Installations in Boats
- NMEA 0400 Installation Standard
- ABYC E-11 AC & DC Electrical Systems on Boats
- ABYC A-31 Battery chargers and Inverters
- ABYC TE-4 Lightning Protection

**Warning: Product grounding**

Before applying power to this product, ensure it has been correctly grounded, in accordance with the instructions provided.

**Warning: Positive ground systems**

Do not connect this unit to a system which has positive grounding.

Grounding — optional dedicated drain wire

Frequencies emitted from equipment such as switch mode power supplies or MF/HF transmitters etc. can cause interference with your MFD's touchscreen. If you experience issues with touchscreen performance, fitting an additional dedicated drain wire can resolve the issue.

Note:

The additional wire supplements the drain wire (shield) that is part of the product's power cable and should ONLY be used when touchscreen interference is observed.

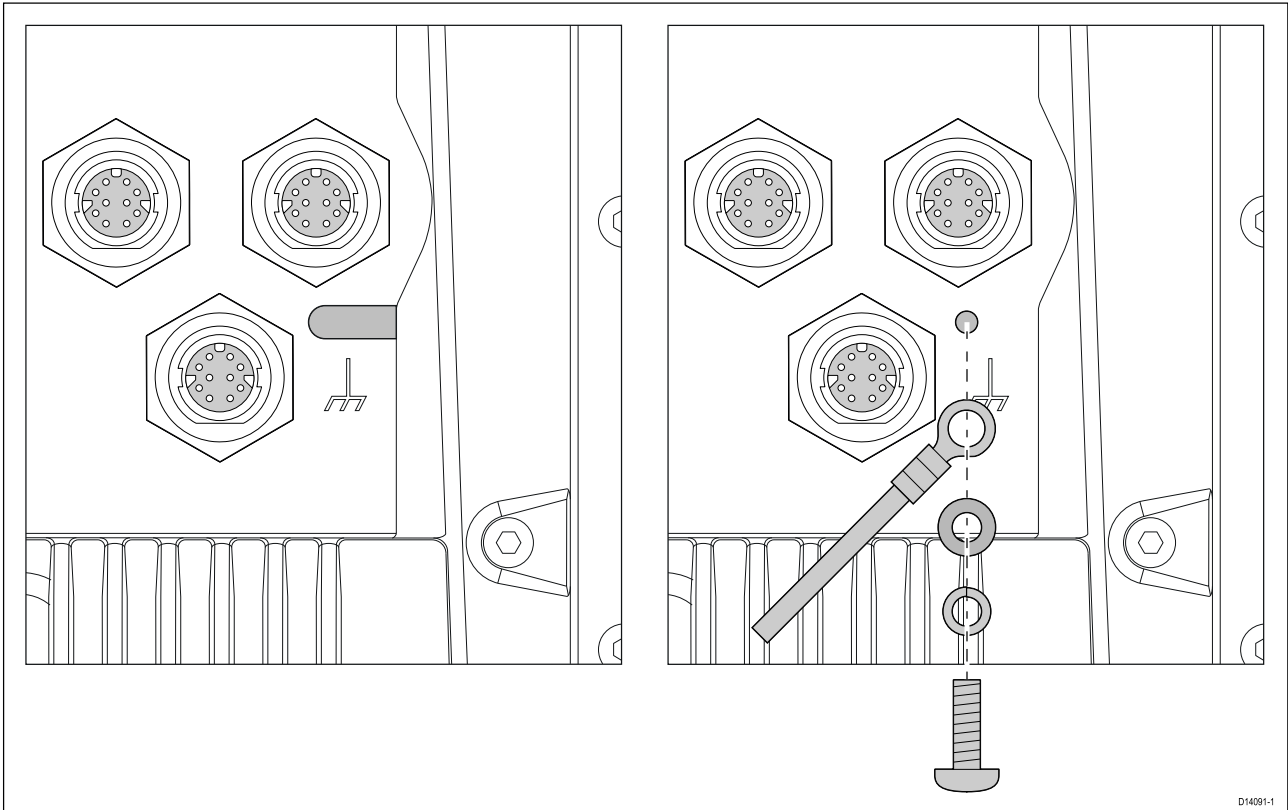

Use a small flat blade screw driver to remove the cover over the grounding screw hole.

Connect one end of the additional drain wire (not supplied) to your product.

Connect the other end of the additional drain wire to the same point as the power cable drain wire (shield). This will be either the vessel's RF ground point, or on vessels without an RF ground system, the negative battery terminal.

The dc power system should be either:

- Negative grounded, with the negative battery terminal connected to the vessel's ground; or
- Floating, with neither battery terminal connected to the vessel's ground.

If several items require grounding, they may first be connected to a single local point (e.g. within a switch panel), with this point connected via a single, appropriately-rated conductor, to the vessel's common RF ground point.

Implementation

The preferred minimum requirement for the path to ground is via a flat tinned copper braid, with a 30 A rating (1/4 inch) or greater. If this is not possible, an equivalent stranded wire conductor may be used, rated as follows:

- for runs of <1 m (3 ft), use 6 mm² (#10 AWG) or greater.
- for runs of >1 m (3 ft), use 8 mm² (#8 AWG) or greater.

In any grounding system, always keep the length of connecting braid or wires as short as possible.

References

- ISO10133/13297
- BMEA code of practice
- NMEA 0400

4.3 NMEA 2000 (SeaTalkng®) connection

The MFD can transmit and receive data from devices connected on a compliant CAN bus network. The MFD is connected to the backbone using the MFD's NMEA 2000 connector.

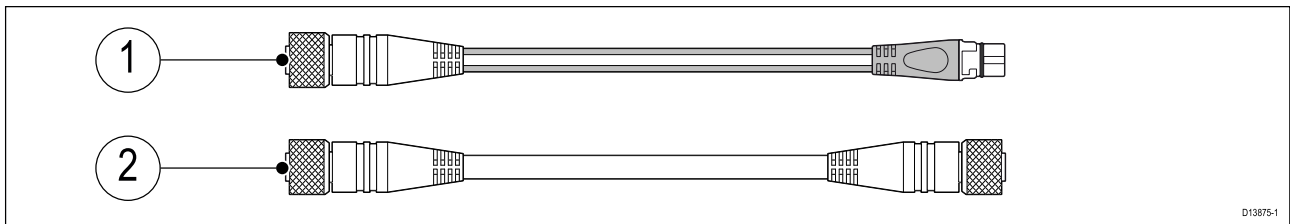

1. Use the supplied DeviceNet to SeaTalkng® adaptor cable to connect your MFD to a SeaTalkng® backbone.
2. Alternatively you can connect your MFD to a NMEA 2000 backbone using a standard DeviceNet cable (not supplied).

Note:

1. SeaTalkng® and NMEA 2000 devices must be connected to a correctly terminated backbone that the MFD is also connected to. Devices cannot be connected directly to the MFD.
2. Refer to the instructions supplied with your SeaTalkng® / NMEA 2000 device for details on creating a backbone.

4.4 NMEA 0183 connection

NMEA 0183 devices can be connected to your MFD using the NMEA 0183 wires on the supplied Power/Video/NMEA 0183 cable.

2 NMEA 0183 ports are available:

- **Port 1:** Input and output 4,800 or 38,400 baud rate.
- **Port 2:** Input only 4,800 or 38,400 baud rate.

Note:

- The Baud rate for each port must be set in your MFD's settings, refer to the operation instructions for your MFD for details on specifying baud rate.
- For Port 1, both the input and output communicate at the same baud rate. For example, if you have one NMEA 0183 device connected to Port 1 INPUT, and another NMEA 0183 device connected to Port 1 OUTPUT, both NMEA devices must use the same baud rate.

Up to 4 devices can be connected to the display's output port and up to 2 devices to the display's input ports.

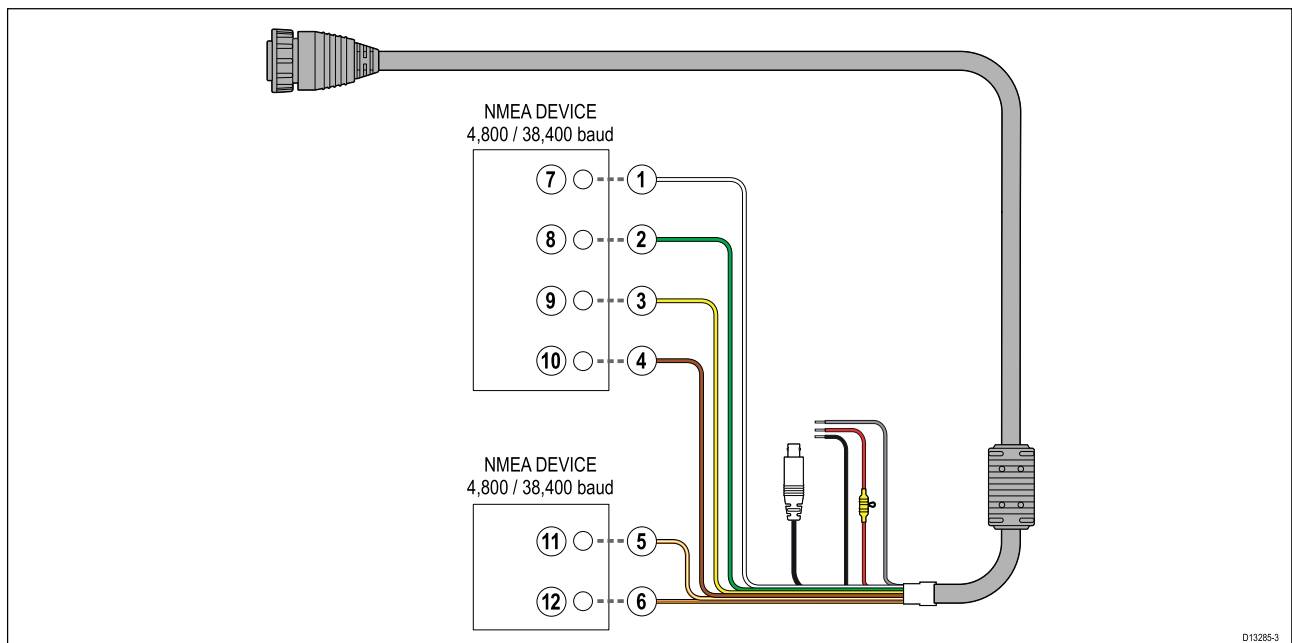

Item	Device	Cable color	Port	Input / output	Positive (+) / negative (-)
1	MFD	White	1	Input	Positive
2		Green	1	Input	Negative
3		Yellow	1	Output	Positive
4		Brown	1	Output	Negative
5		Orange / White	2	Input	Positive
6		Orange / Green	2	Input	Negative
7	NMEA device	*	*	Output	Positive
8		*	*	Output	Negative
9		*	*	Input	Positive
10		*	*	Input	Negative
11	NMEA device	*	*	Output	Positive
12		*	*	Output	Negative

Note:

* Refer to instructions provided with your NMEA 0183 device for connection details.

4.5 Network connection

Your MFD can be directly connected to a compatible product using the RayNet connection. Your MFD can also be connected to a SeaTalkhs[®] network when using a suitable network switch.

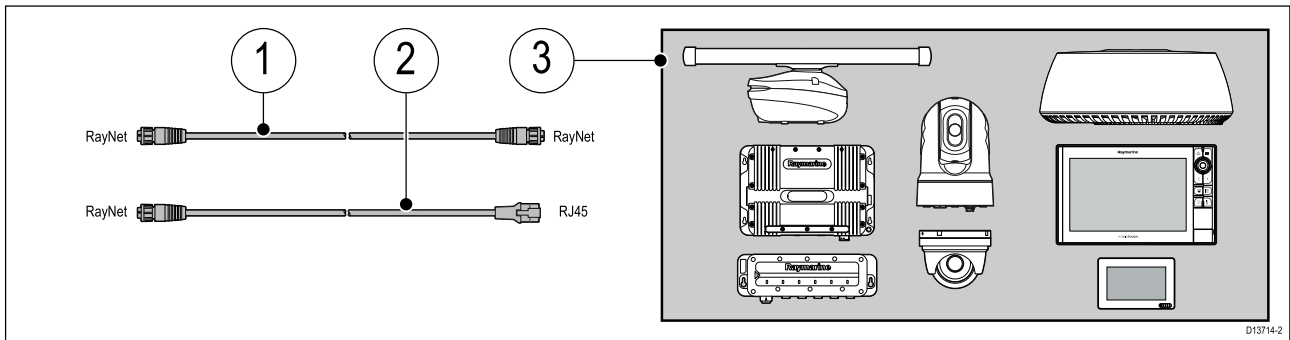

1. RayNet to RayNet cable — Connect one end of the RayNet cable to your MFD and the opposite end to a RayNet device or RayNet network switch.
2. RayNet to RJ45 cable — Connect the RayNet end of the cable to your MFD and the opposite end to a RJ45 device or RJ45 network switch or coupler.
3. Compatible network devices, such as a Network switch, Radar scanner, Sonar module, Thermal camera etc.

Note:

- Refer to the instructions supplied with your network product for specific connection information.
- Refer to [Chapter 9 Spares and accessories](#) for a list of available network cables.

Cable suppression ferrites

To ensure optimum EMC performance and to comply with applicable EMC regulations any RayNet cables connected to this product must have a suppression ferrite fitted.

Three suppression ferrites are included with your display, one for each RayNet connection.

Fit a ferrite to each RayNet cable as shown below:

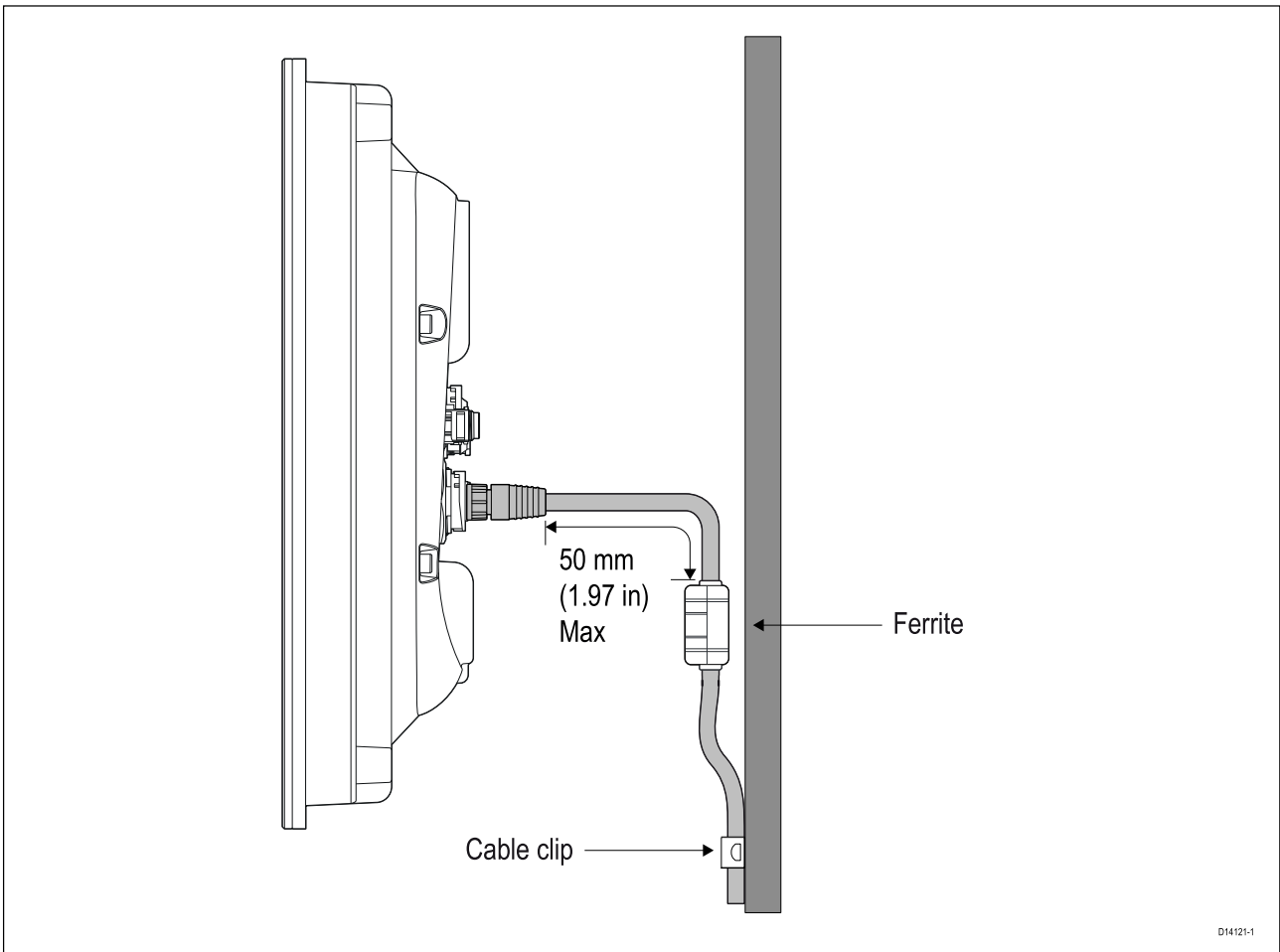

- Cable clips (not supplied) should be used to support the cable and ferrite.
- If you need to remove a ferrite for any reason, ensure it is replaced in its original location before using the product.
- If the ferrite moves freely once fitted to the RayNet cable use cable ties (not supplied) above and below the ferrite to secure in place.

Power over Ethernet (PoE)

Your MFD is a PSE (Power Sourcing Equipment) which supplies power over the network connections to connected PoE powered device (PD). The MFD can output a maximum of 32 Watts (26 W @ PD) for consumption by up to 3 PoE powered devices.

The following PoE device classes are supported:

PoE device class	PSE (power supplied by MFD)	PD (Power required by device)	Class description
Class 1	4 W	3.84 W	Very low power
Class 2	7 W	6.49 W	Low power
Class 3	15.4 W	12.95 W	Mid power
Class 4	30 W	25.5 W	High power
Class 0	15.4 W	12.95 W	Classification unimplemented

When a device is connected to the network connection it is interrogated to establish if the device is a PoE powered device and if so what class of device it is. The maximum power for that device class (shown in the PSE column above) is then assigned to that port and deducted from the remaining power output (e.g. class 2 device = 7 W allocated, 25 W remaining).

If a PoE powered device is connected that will take the total assigned power over 32 W (26 W @ PD) then the device will not be allocated PoE power.

The following combinations of PoE devices can be powered by the MFD:

- 1 x class 4 device

- 2 x class 3 or class 0 devices
- 3 x class 2 devices
- 3 x class 1 devices

PoE connections

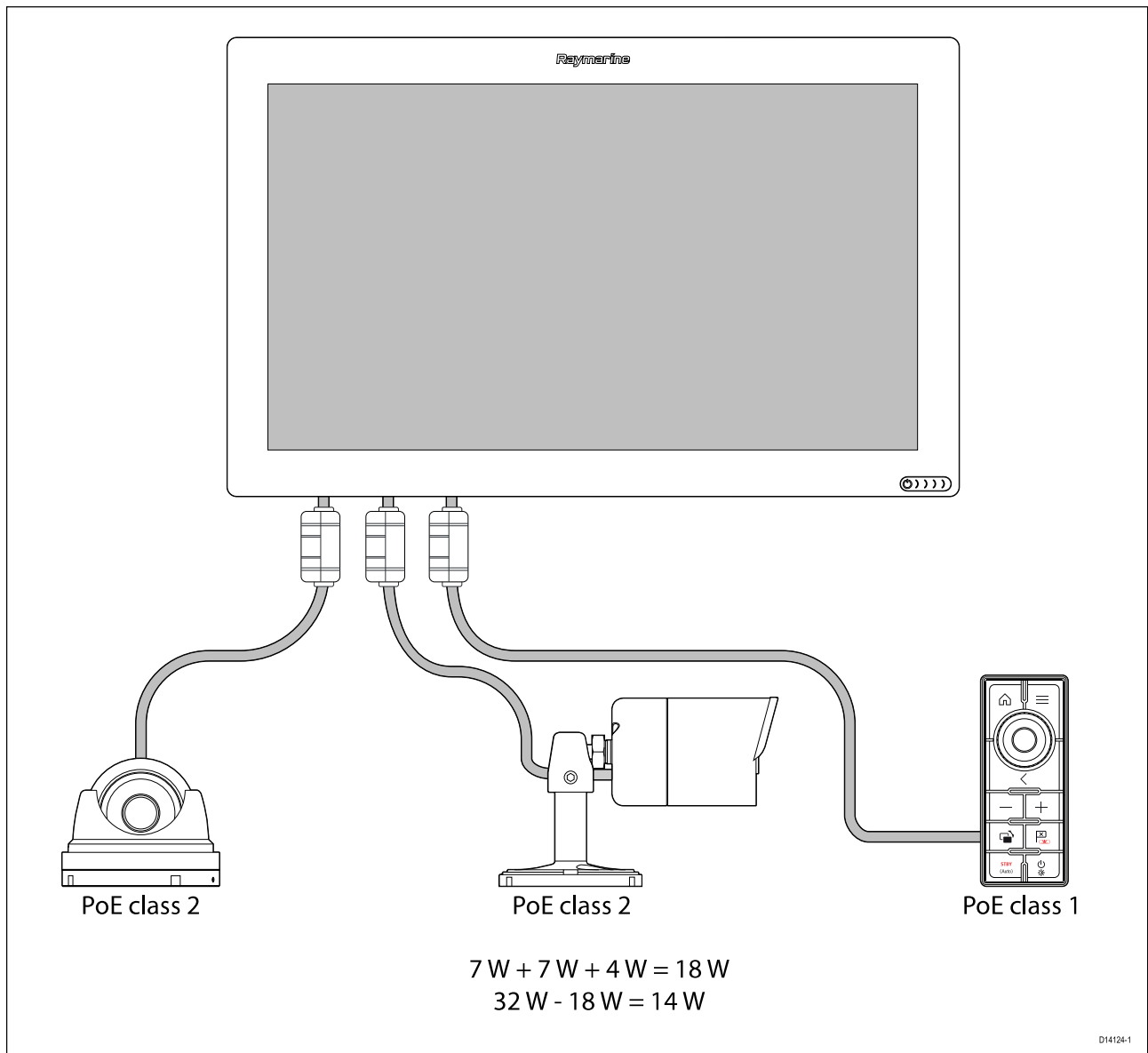

In the example above the combination of the 3 PoE devices power requirements does not exceed the PoE available from the MFD. All 3 devices will be powered by the MFD.

Important:

- The PoE devices should be connected using RayNet cables.
- The ferrites supplied with your MFD must be used on all RayNet network connections.
- The power supply at the MFD must exceed 9.5 V dc for PoE to be available.

4.6 GA150 connection

A passive antenna, such as the GA150 (A80288) is required to obtain a position fix using the MFDs built-in GNSS (GPS) receiver.



For installation details, refer to the documentation provided with your GA150.

4.7 Remote alarm connection

A remote alarm can be connected to the Alarm / Video connector on your MFD using the Video in / Alarm out cable.

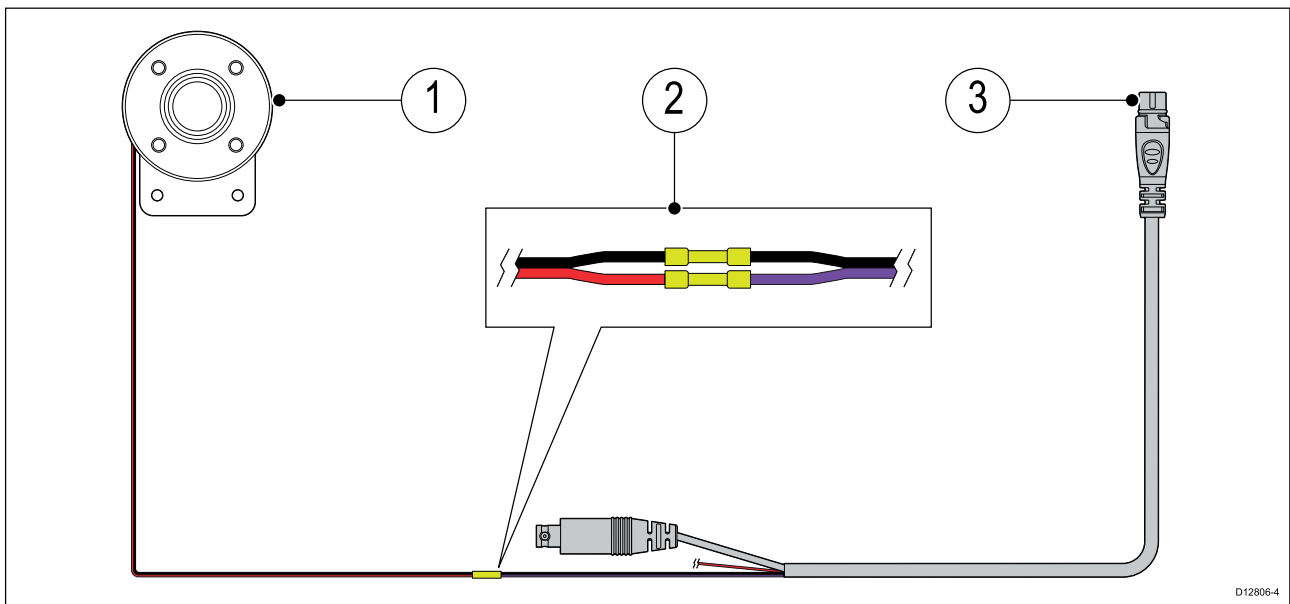

1. Remote MFD alarm buzzer (E26033).
2. Connection — Wires should be connected **Black to Black** and **Red to Purple**.
3. Video In / Alarm out cable (A80235).

Note:

The remote alarm to cable connection should be made using suitable connectors (e.g. crimps) and then covered in insulation tape or similar to ensure the connection is secure and watertight.

4.8 Accessory connection

The RCR-SDUSB or RCR-2 can be connected to your MFD using the Accessory connection.

RCR connection

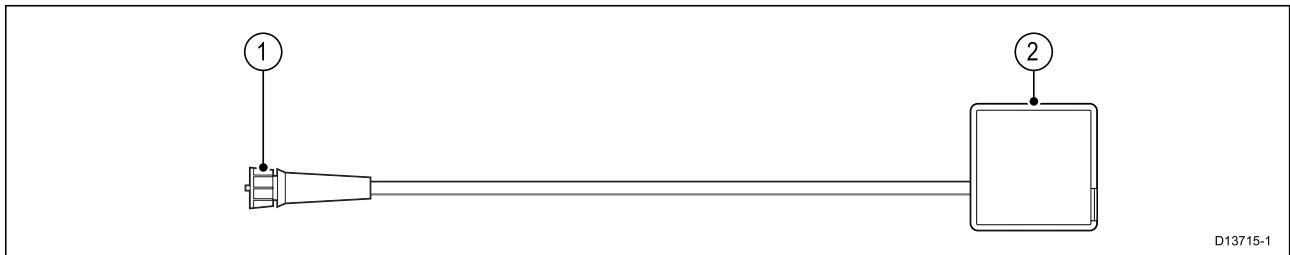

The RCR-SDUSB accessory can provide your MFD with extra storage by connecting external storage devices i.e.:

- SD card (or MicroSD card when using a SD card adaptor)
- external hard disk drive (HDD) or pen/flash drive

The HDD/flash drive slot can also supply 0.5A of current to charge mobile devices.

The RCR-2 accessory can provide your MFD with 2 x extra MicroSDHC card slots.

For installation details please refer to the instructions provided with your accessory.



Warning: USB device power

Do NOT connect any device to the product's USB connection that requires an external power source.

4.9 HDMI in connection

High definition video can be viewed by connecting a video player to the HDMI in connection and using the Video app to view the feed.

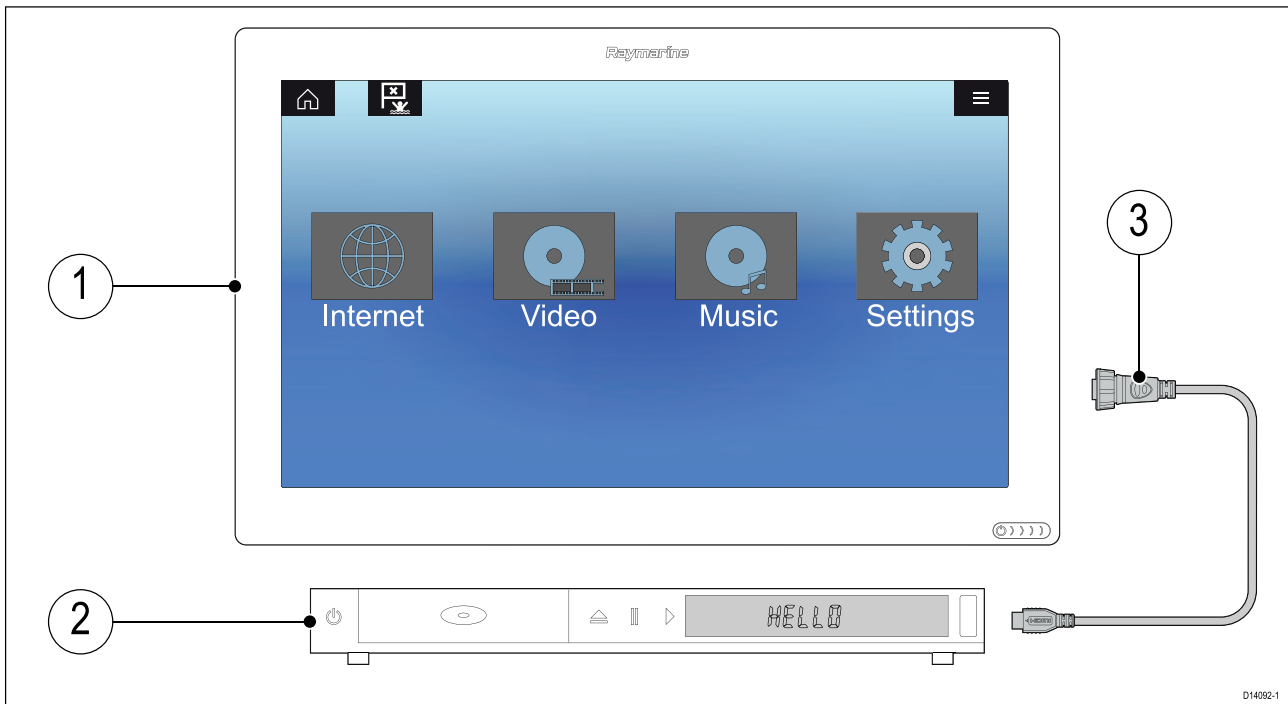

1. Axiom XL MFD.
2. High Definition video player (e.g.: Blu-ray player).
3. HDMI cable (A80219).

To listen to the video feed's audio track you require an audio output device this can be:

- A Bluetooth speaker connected to your MFD.
- Speaker or sound system connected directly to your video player.
- Sound system connected to the MFD's HDMI out connection.

Note:

- The **HDMI in** and **Video 2** analog connections share hardware internal to the MFD and so cannot be used at the same time. If devices are connected to both connections then the **HDMI in** connection will take priority.
- The video feed connected to the **HDMI in** connection is NOT streamed over the SeaTalkhs[®] network to other MFDs.

4.10 HDMI out connection

You can output the MFD's screen to a High Definition display such as a HDTV or HD monitor by connecting your display to the HDMI out connection.

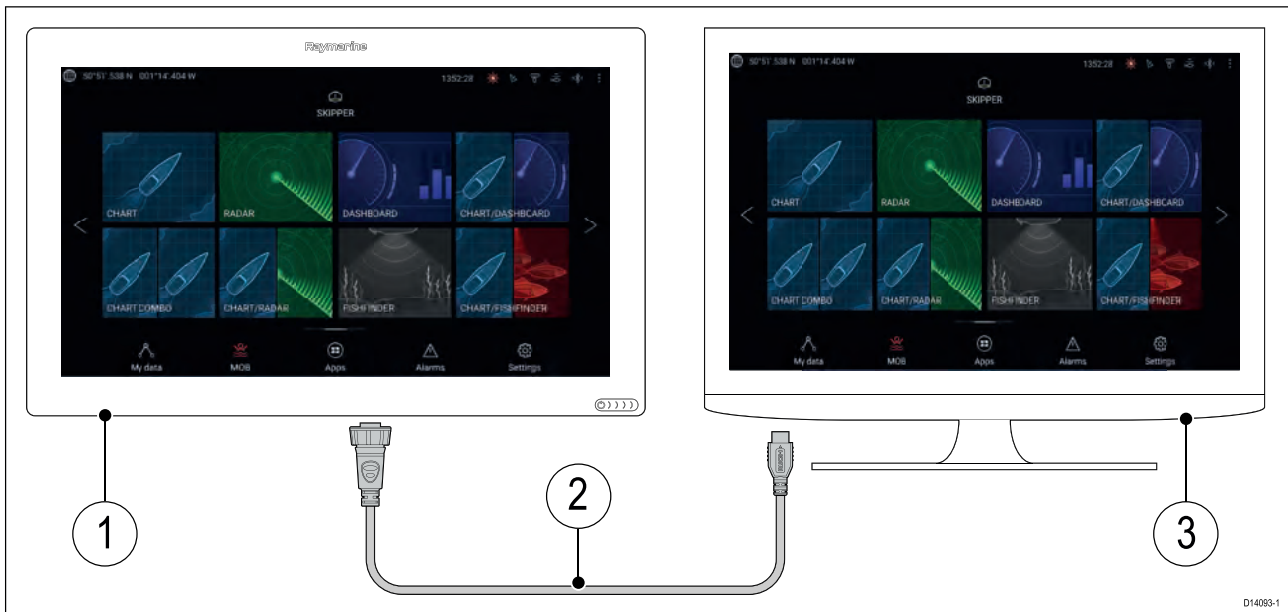

1. Axiom XL MFD.
2. HDMI cable (A80219).
3. Display (e.g.: HDTV or HD monitor).

4.11 Touch in connection

The touch in connection combined with a HDMI out connection can be used to view and control your MFD remotely from a connected touchscreen monitor.

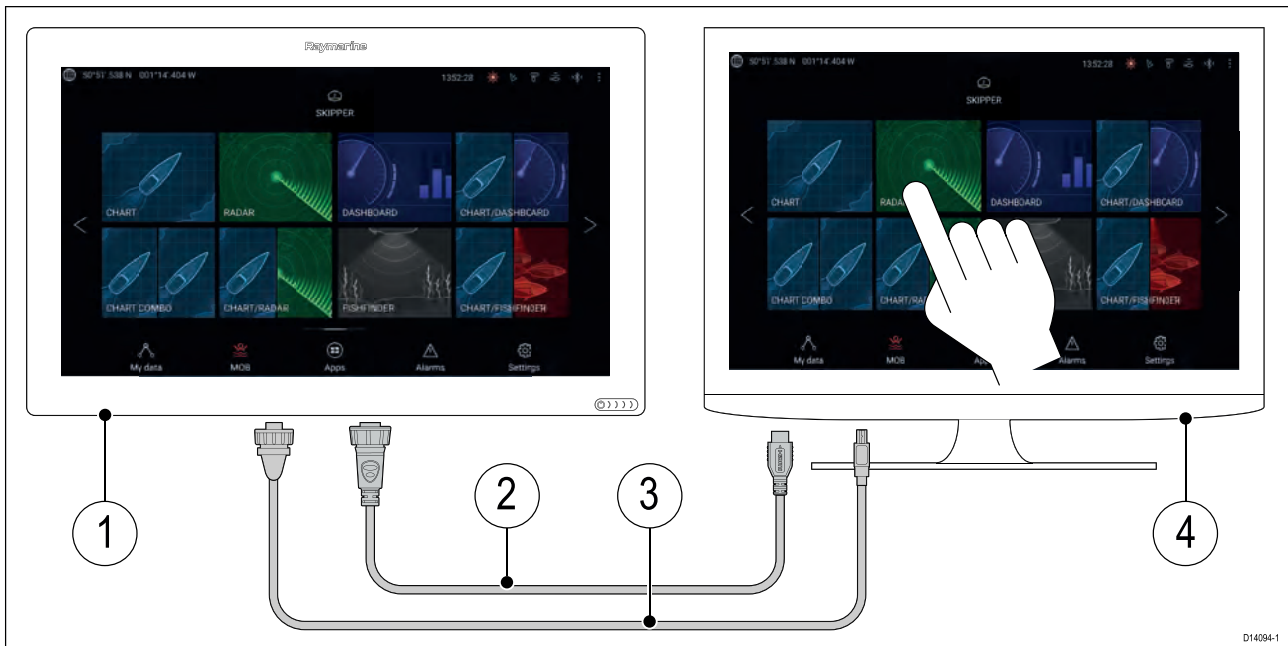

1. Axiom XL MFD.
2. HDMI cable (A80219).
3. USB A to USB B cable (A80578).
4. Touchscreen display.

4.12 Touch out connection

The touch out connection combined with a HDMI in connection can be used to view and control a compatible PC or similar device remotely using your MFD.

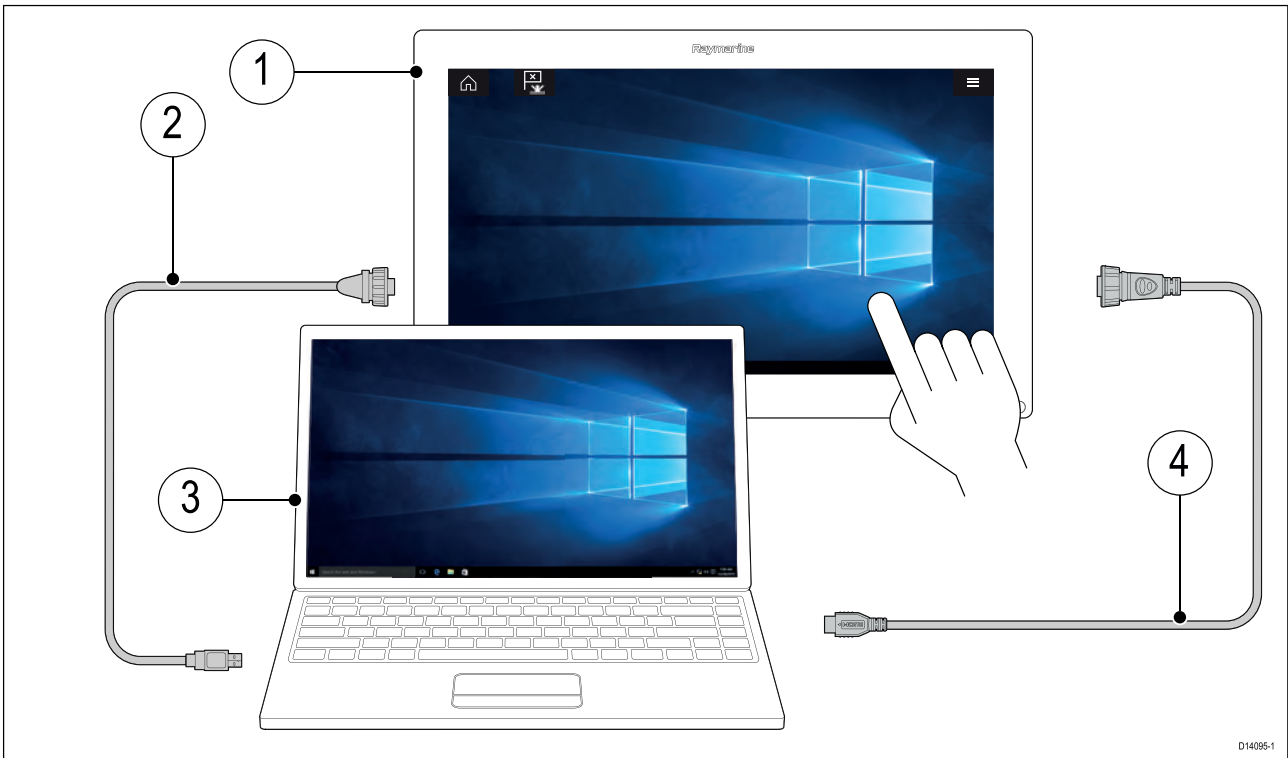

1. Axiom XL MFD.
2. USB B to USB A cable (A80579).
3. Personal computer (e.g.: laptop).
4. HDMI cable (A80219).

Note:

The **HDMI in** and **Video 2** analog connections share hardware internal to the MFD and so cannot be used at the same time. If devices are connected to both connections then the **HDMI in** connection will take priority.

4.13 Analog video (Video 1) connection

Analog video sources such as a Thermal camera or security camera can be connected to your MFD using the BNC connector on the Alarm/Video cable. Your MFD will stream the feed over the SeaTalkhs[®] network to other compatible MFDs.

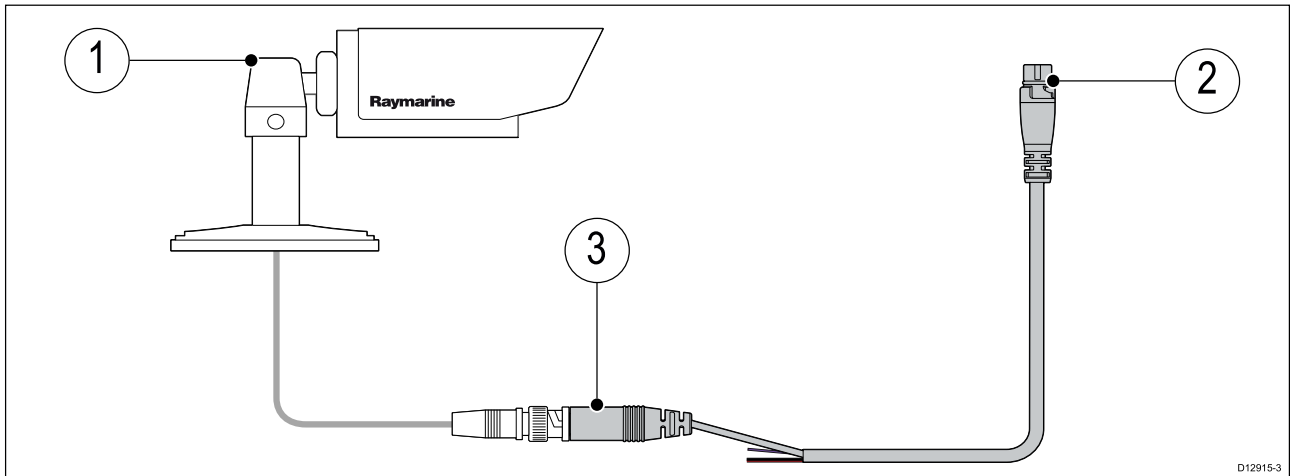

1. Analog video device.
2. Video in / Alarm out cable (A80235).
3. (Video 1) Analog video BNC connector.

For installation details, refer to the documentation provided with your analog video device.

4.14 Analog video (Video 2) connection

Analog video sources such as a Thermal or security camera can be connected to your MFD using the BNC connector on the supplied Power/Video/NMEA 0183 cable. Your MFD will NOT stream this feed over the SeaTalkhs[®] network.

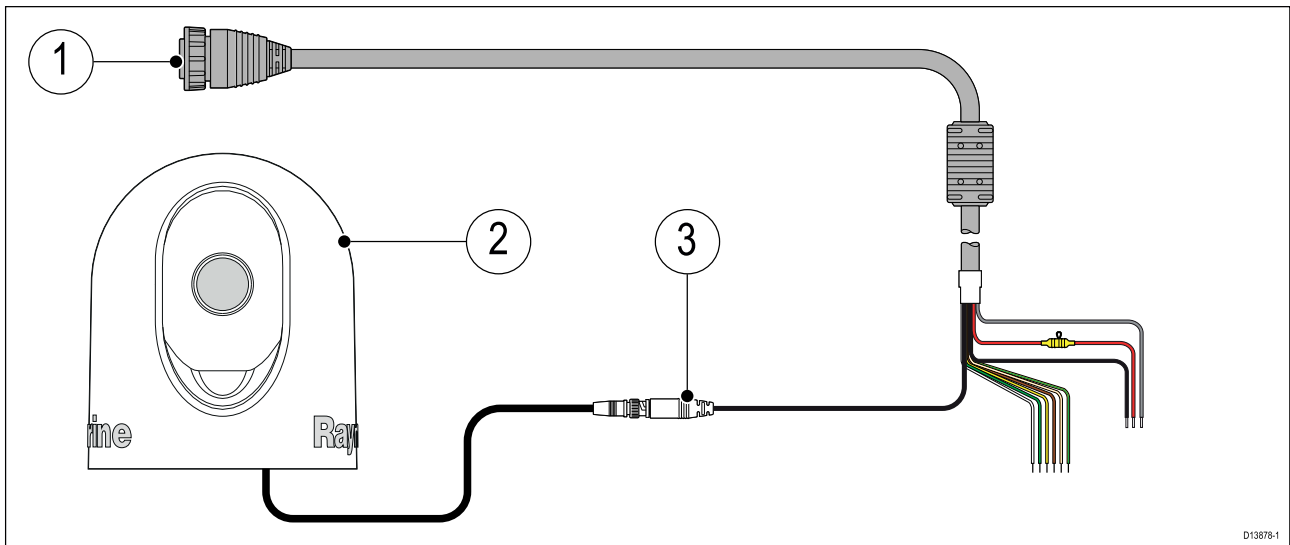

1. Power/Video/NMEA 0183 cable supplied with your MFD.
2. Analog video device.
3. (Video 2) Analog video BNC connector.

For installation details, refer to the documentation provided with your analog video device.

Note:

The **HDMI in** and **Video 2** analog connections share hardware internal to the MFD and so cannot be used at the same time. If devices are connected to both connections then the **HDMI in** connection will take priority.

Chapter 5: Maintaining your display

Chapter contents

- [5.1 Service and maintenance on page 50](#)
- [5.2 Product cleaning on page 51](#)

5.1 Service and maintenance

This product contains no user serviceable components. Please refer all maintenance and repair to authorized Raymarine dealers. Unauthorized repair may affect your warranty.



Warning: High voltages

This product may contain high voltages. Do NOT remove any covers or otherwise attempt to access internal components, unless specifically instructed in the documentation provided.



Warning: FCC Warning (Part 15.21)

Changes or modifications to this equipment not expressly approved in writing by Raymarine Incorporated could violate compliance with FCC rules and void the user's authority to operate the equipment.

Caution: Sun covers

- If your product is supplied with a sun cover, to protect against the damaging effects of ultraviolet (UV) light, always fit the sun cover when the product is not in use.
- Sun covers must be removed when travelling at high speed, whether in water or when the vessel is being towed.

Routine equipment checks

It is recommended that you perform the following routine checks, on a regular basis, to ensure the correct and reliable operation of your equipment:

- Examine all cables for signs of damage or wear and tear.
- Check that all cables are securely connected.

5.2 Product cleaning

Best cleaning practices.

When cleaning products:

- Lightly rinse or flush with clean, cool fresh water.
- If your product has a display screen, do NOT wipe the screen with a dry cloth, as this could scratch the screen coating.
- Do NOT use: abrasive, acidic, ammonia, solvent or chemical based cleaning products.
- Do NOT use a jet wash.

Cleaning the display case

The display unit is a sealed unit and does not require regular cleaning. If it is necessary to clean the unit, follow this basic procedure:

1. Switch off the power to the display.
2. Wipe the display with a clean, soft cloth (a microfibre cloth is ideal).
3. If necessary, use a mild detergent to remove grease marks.

Note: Do NOT use solvents or detergents on the screen itself.

Cleaning the display screen

A coating is applied to the display screen. This makes it water repellent, and prevents glare. To avoid damaging this coating, follow this procedure:

1. Switch off the power to the display.
2. Rinse the screen with fresh water to remove all dirt particles and salt deposits.
3. Allow the screen to dry naturally.
4. If any smears remain, very gently wipe the screen with a clean microfibre cleaning cloth.

Cleaning the sun cover

The supplied sun cover features an adhesive surface. In certain conditions unwanted contaminants may stick to this surface. To avoid damaging the monitor display, clean the sun cover regularly following this procedure:

1. Carefully remove the sun cover from the display.
2. Rinse the sun cover with fresh water to remove all dirt particles and salt deposits.
3. Allow the sun cover to dry naturally.

Chapter 6: Troubleshooting

Chapter contents

- [6.1 Troubleshooting on page 54](#)
- [6.2 Power up troubleshooting on page 55](#)
- [6.3 GNSS troubleshooting on page 56](#)
- [6.4 Sonar troubleshooting on page 57](#)
- [6.5 Wi-Fi troubleshooting on page 60](#)
- [6.6 Touchscreen troubleshooting on page 63](#)
- [6.7 Miscellaneous troubleshooting on page 64](#)

6.1 Troubleshooting

The troubleshooting information provides possible causes and corrective action required for common problems associated with installation and operation of your product.

Before packing and shipping, all Raymarine products are subjected to comprehensive testing and quality assurance programs. If you do experience problems with your product this section will help you to diagnose and correct problems in order to restore normal operation.

If after referring to this section you are still having problems with your product, please refer to the Technical support section of this manual for useful links and Raymarine Product Support contact details.

6.2 Power up troubleshooting

Product does not turn on or keeps turning off

Possible causes	Possible solutions
Blown fuse / tripped breaker	<ol style="list-style-type: none"> 1. Check condition of relevant fuses and breakers and connections, replace if necessary. (Refer to the <i>Technical Specification</i> section of your product's installation instructions for fuse ratings.) 2. If fuse keeps blowing check for cable damage, broken connector pins or incorrect wiring.
Poor / damaged / insecure power supply cable / connections	<ol style="list-style-type: none"> 1. Check that the power cable connector is fully inserted into the unit and locked in position. 2. Check the power supply cable and connectors for signs of damage or corrosion, and replace if necessary. 3. With the unit turned on, try flexing the power cable near to the display connector to see if this causes the unit to restart or lose power; replace if necessary. 4. Check the vessel's battery voltage and the condition of the battery terminals and power supply cables, ensuring connections are secure, clean and free from corrosion. Replace if necessary. 5. With the product under load, using a multi-meter, check for high voltage drop across all connectors / fuses etc, and replace if necessary.
Incorrect power connection	The power supply may be wired incorrectly, ensure the installation instructions have been followed.
Power source insufficient	With the product under load, using a multi-meter, check the power supply voltage as close to the unit as possible to establish actual voltage when the current is flowing. (Refer to the <i>Technical Specification</i> section of your product's installation instructions for power supply requirements.)

Product will not start up (restart loop)

Possible causes	Possible solutions
Power supply and connection	See possible solutions from the table above, entitled 'Product does not turn on or keeps turning off'.
Software corruption	<ol style="list-style-type: none"> 1. In the unlikely event that the product's software has become corrupted, try downloading and installing the latest software from the Raymarine website. 2. On display products, as a last resort, attempt to perform a 'Power on Reset'. Be aware that this will delete all settings / presets and user data (such as waypoints and tracks), and revert the unit back to factory defaults.

Performing a power on reset – Axiom™

1. Within 60 seconds of powering on your MFD, swipe your finger from right to left (opposite direction to powering on) across the **Power** button swipe area 5 times.
Recovery options are displayed.
2. Swipe your finger from right to left twice to highlight **Wipe data/factory reset**.
3. Swipe your finger from left to right once to accept.
4. Swipe your finger from right to left once to highlight **Yes**.
5. Swipe your finger from left to right once to restore your MFD to factory default settings.
6. When **Data wipe complete** is displayed, swipe your finger from left to right to reboot your MFD.

6.3 GNSS troubleshooting

Problems with the GNSS and their possible causes and solutions are described here.

Problem	Possible causes	Possible solutions
“No Fix” GNSS status icon is displayed.	Geographic location or prevailing conditions preventing satellite fix.	Check periodically to see if a fix is obtained in better conditions or another geographic location.
	GNSS connection fault.	Ensure that external GNSS connections and cabling are correct and fault free.
	External GNSS receiver in poor location. For example: <ul style="list-style-type: none"> • Below decks. • Close proximity to transmitting equipment such as VHF radio. 	Ensure GNSS receiver has a clear view of the sky.
	GNSS installation problem.	Refer to the installation instructions.
<p>Note: A GNSS Status screen is accessible from the display. This provides satellite signal strength and other relevant information.</p>		

6.4 Sonar troubleshooting

Problems with the sonar and their possible causes and solutions are described here.

Scrolling image is not being displayed

Possible causes	Possible solutions
Sonar disabled	Select Ping Enable from the Sonar app's Sounder menu.
Incorrect transducer selected	Check that the correct transducer is selected in the Sonar app's Transducer menu.
Damaged cables	<ol style="list-style-type: none"> 1. Check that the transducer cable connector is fully inserted and locked in position. 2. Check the power supply cable and connectors for signs of damage or corrosion, replace if necessary. 3. With the unit turned on, try flexing the cable near to the display connector to see if this causes the unit to re-boot/loose power, replace if necessary. 4. Check the vessel's battery voltage, the condition of the battery terminals and power supply cables, ensuring connections are secure, clean and free from corrosion, replace if necessary. 5. With the product under load, using a multi-meter, check for high voltage drop across all connectors/fuses etc (this can cause the Sonar applications to stop scrolling or the unit to reset/turn off), replace if necessary.
Damaged or fouled transducer	Check the condition of the transducer ensuring it is not damaged and is free from debris/fouling, clean or replace as necessary.
Wrong transducer fitted	Ensure the transducer is compatible with your system.
External sonar module: SeaTalkhs™ / RayNet network problem.	<ul style="list-style-type: none"> • Check that the unit is correctly connected to the multifunction display or Raymarine network switch. If a crossover coupler or other coupler cable / adapter is used, check all connections ensuring connections are secure, clean and free from corrosion, replace if necessary.
External sonar module: Software mismatch between equipment may prevent communication.	Ensure all Raymarine products contain the latest available software, check the Raymarine website: www.raymarine.com/software for software compatibility.

No depth reading / lost bottom lock

Possible causes	Possible solutions
Transducer location	Check that the transducer has been installed in accordance with the instructions provided with the transducer.
Transducer angle	If the transducer angle is too great the beam can miss the bottom, adjust transducer angle and recheck.
Transducer kicked-up	If the transducer has a kick-up mechanism, check that it has not kicked up due to hitting an object.
Power source insufficient	With the product under load, using a multi-meter, check the power supply voltage as close to the unit as possible to establish actual voltage when the current is flowing. (Check your product's Technical specification for power supply requirements.)
Damaged or fouled transducer	Check the condition of the transducer ensuring it is not damaged and is free from debris / fouling.

Possible causes	Possible solutions
Damaged cables	<ol style="list-style-type: none"> 1. Check the unit's connector for broken or bent pins. 2. Check that the cable connector is fully inserted into the unit and that the locking collar is in the locked position. 3. Check the cable and connectors for signs of damage or corrosion, replace if necessary. 4. With the unit turned on, try flexing the power cable near to the display connector to see if this causes the unit to re-boot/loose power, replace if necessary. 5. Check the vessel's battery voltage, the condition of the battery terminals and power supply cables, ensuring connections are secure, clean and free from corrosion, replace if necessary. 6. With the product under load, using a multi-meter, check for high voltage drop across all connectors/fuses etc (this can cause the Sonar applications to stop scrolling or the unit to reset/turn off), replace if necessary.
Vessel speed too high	Slow vessel speed and recheck.
Bottom too shallow or too deep	The bottom depth may be outside of the transducers depth range, move vessel to shallower or deeper waters as relevant and recheck.

Poor / problematic image

Possible causes	Possible solutions
Vessel stationary	Fish arches are not displayed if the vessel is stationary; fish will appear on the display as straight lines.
Scrolling paused or speed set too low	Unpause or increase sonar scrolling speed.
Sensitivity settings may be inappropriate for present conditions.	Check and adjust sensitivity settings or perform a Sonar reset.
Damaged cables	<ol style="list-style-type: none"> 1. Check the unit's connector for broken or bent pins. 2. Check that the cable connector is fully inserted into the unit and that the locking collar is in the locked position. 3. Check the cable and connectors for signs of damage or corrosion, replace if necessary. 4. With the unit turned on, try flexing the power cable near to the display connector to see if this causes the unit to re-boot/loose power, replace if necessary. 5. Check the vessel's battery voltage, the condition of the battery terminals and power supply cables, ensuring connections are secure, clean and free from corrosion, replace if necessary. 6. With the product under load, using a multi-meter, check for high voltage drop across all connectors/fuses etc (this can cause the Sonar applications to stop scrolling or the unit to reset/turn off), replace if necessary.

Possible causes	Possible solutions
Transducer location	<ul style="list-style-type: none"> • Check that the transducer has been installed in accordance with the instructions provided with the transducer. • If a transom mount transducer is mounted too high on the transom it may be lifting out of the water, check that the transducer face is fully submerged when planing and turning.
Transducer kicked-up	If the transducer has a kick-up mechanism, check that it has not kicked up due to hitting an object.
Damaged or fouled transducer	Check the condition of the transducer ensuring it is not damaged and is free from debris / fouling.
Damaged transducer cable	Check that the transducer cable and connection is free from damage and that the connections are secure and free from corrosion.
Turbulence around the transducer at higher speeds may affect transducer performance	Slow vessel speed and recheck.
Interference from another transducer	<ol style="list-style-type: none"> 1. Turn off the transducer causing the interference. 2. Reposition the transducers so they are further apart.
Unit power supply fault	Check the voltage from the power supply, if this is too low it can affect the transmitting power of the unit.

6.5 Wi-Fi troubleshooting

Before troubleshooting problems with your Wi-Fi connection, ensure that you have followed the Wi-Fi location requirements guidance provided in the relevant installation instructions and performed a power cycle/reboot of the devices you are experiencing problems with.

Cannot find network

Possible cause	Possible solutions
Wi-Fi not currently enabled on devices.	Ensure Wi-Fi is enabled on both Wi-Fi devices and rescan available networks.
Some devices may automatically turn off Wi-Fi when not in use to save power.	Power cycle / reboot devices and rescan available networks.
Device not broadcasting.	<ol style="list-style-type: none"> 1. Try to enable broadcasting of the device's network using the Wi-Fi settings on the device you are trying to connect to. 2. You may still be able to connect to the device, when it is not broadcasting, by manually entering the device's Wi-Fi Name / SSID and passphrase in the connection settings of the device you are trying to connect.
Devices out of range or signal being blocked.	Move devices closer together or, if possible remove the obstructions and then rescan available network.

Cannot connect to network

Possible cause	Possible solutions
Some devices may automatically turn off Wi-Fi when not in use to save power.	Power cycle/reboot devices and retry the connection.
Trying to connect to the wrong Wi-Fi network	Ensure you are trying to connect to the correct Wi-Fi network, the Wi-Fi network's name can be found in the Wi-Fi settings on the broadcasting device (the device that you are trying to connect to).
Incorrect network credentials	Ensure you are using the correct passphrase, the Wi-Fi network's passphrase can be found in the Wi-Fi settings on the broadcasting device (the device that you are trying to connect to).
Bulkheads, decks and other heavy structure can degrade and even block the Wi-Fi signal. Depending on the thickness and material used it may not always be possible to pass a Wi-Fi signal through certain structures	<ol style="list-style-type: none"> 1. Try repositioning the devices so the structure is removed from the direct line of sight between the devices, or 2. If possible use a wired connection instead.
Interference being caused by other Wi-Fi enabled or older Bluetooth enabled devices (Bluetooth and Wi-Fi both operate in the 2.4 GHz frequency range, some older bluetooth devices may interfere with Wi-Fi signals.)	<ol style="list-style-type: none"> 1. Change the Wi-Fi Channel of the device you are trying to connect to and retry the connection. You can use free Wi-Fi analyzer apps on your smart device to help you choose a better channel (channel with least traffic). 2. Temporarily disable each wireless device in turn until you have identified the device causing the interference.

Possible cause	Possible solutions
<p>Interference caused by other devices that use the 2.4GHz frequency See list below of some common devices that use the 2.4GHz frequency:</p> <ul style="list-style-type: none"> • Microwave ovens • Fluorescent lighting • Cordless phones / baby monitors • Motion sensors 	<p>Temporarily switch off each device in turn until you have identified the device causing the interference, then remove or reposition the offending device(s).</p>
<p>Interference caused by electrical and electronic devices and associated cabling could generate an electromagnetic field which may interfere with the Wi-Fi signal.</p>	<p>Temporarily switch off each item in turn until you have identified the device causing the interference, then remove or reposition the offending device(s).</p>

Connection extremely slow and or keeps dropping out

Possible cause	Possible solutions
<p>Wi-Fi performance degrades over distance so products farther away will receive less network bandwidth. Products installed close to their maximum Wi-Fi range will experience slow connection speeds, signal drop outs or not being able to connect at all.</p>	<ul style="list-style-type: none"> • Move devices closer together. • For fixed installations such as a Quantum Radar, enable the Wi-Fi connection on an MFD installed closer to the device.
<p>Interference being caused by other Wi-Fi enabled or older Bluetooth enabled devices (Bluetooth and Wi-Fi both operate in the 2.4 GHz frequency range, some older bluetooth devices may interfere with Wi-Fi signals.)</p>	<ol style="list-style-type: none"> 1. Change the Wi-Fi Channel of the device you are trying to connect to and retry the connection. You can use free Wi-Fi analyzer apps on your smart device to help you choose a better channel (channel with least traffic). 2. Temporarily switch off each device in turn until you have identified the device causing the interference, then remove or reposition the offending device(s).
<p>Interference from devices on other vessels. When in close proximity to other vessels, for example, when moored up in a marina, many other Wi-Fi signals may be present.</p>	<ol style="list-style-type: none"> 1. Change the Wi-Fi Channel of the device you are trying to connect to and retry the connection. You can use free Wi-Fi analyzer apps on your smart device to help you choose a better channel (channel with least traffic). 2. If possible, move your vessel to a location with less Wi-Fi traffic.

Network connection established but no data

Possible cause	Possible solutions
<p>Connected to the wrong network.</p>	<p>Ensure that your devices is connected to the correct network.</p>
<p>Device software incompatibility</p>	<p>Ensure both devices are running the latest available software.</p>
<p>It may be possible that the device has become defective</p>	<ol style="list-style-type: none"> 1. Try updating software to a later version, or 2. try reinstalling the software. 3. Obtain new replacement device.

Mobile application running slowly or not at all

Possible cause	Possible solutions
Raymarine app not installed	Install mobile app from relevant app store.
Raymarine app version not compatible with MFD software	Ensure mobile app and MFD software are latest available versions.
Mobile apps not enabled on MFD	Enable “Viewing only” or “Remote Control” as required in the Mobile Apps setting on your MFD.

6.6 Touchscreen troubleshooting

Problems with the touchscreen and their possible causes and solutions are described here.

Problem	Possible causes	Possible solutions
Touchscreen does not operate as expected.	TouchLock is enabled.	Swipe your finger from left to right across the Power button swipe area to de-activate the TouchLock.
	Screen is not being operated with bare fingers, for example gloves are being worn.	Bare fingers must make contact with the screen for correct operation. Alternatively you may use conductive gloves.
	Water deposits on the screen.	Carefully clean and dry the screen in accordance with the instructions provided.

6.7 Miscellaneous troubleshooting

Miscellaneous problems and their possible causes and solutions are described here.

Problem	Possible causes	Possible solutions
Display behaves erratically: <ul style="list-style-type: none"> • Frequent unexpected resets. • System crashes or other erratic behavior. 	Intermittent problem with power to the display.	Check relevant fuses and breakers.
		Check that the power supply cable is sound and that all connections are tight and free from corrosion.
		Check that the power source is of the correct voltage and sufficient current.
	Software mismatch on system (upgrade required).	Go to www.raymarine.com and click on support for the latest software downloads.
Corrupt data / other unknown issue.	Perform a factory reset. <div style="border: 1px solid black; padding: 5px; margin-top: 5px;"> <p>Important: This will result in the loss of any settings and data (such as waypoints) stored on the product. Save any important data to a memory card before resetting.</p> </div>	

Chapter 7: Technical support

Chapter contents

- [7.1 Raymarine product support and servicing on page 66](#)
- [7.2 Learning resources on page 68](#)

7.1 Raymarine product support and servicing

Raymarine provides a comprehensive product support service, as well as warranty, service, and repairs. You can access these services through the Raymarine website, telephone, and e-mail.

Product information

If you need to request service or support, please have the following information to hand:

- Product name.
- Product identity.
- Serial number.
- Software application version.
- System diagrams.

You can obtain this product information using the menus within your product.

Servicing and warranty

Raymarine offers dedicated service departments for warranty, service, and repairs.

Don't forget to visit the Raymarine website to register your product for extended warranty benefits:

<http://www.raymarine.co.uk/display/?id=788>.

Region	Telephone	E-mail
United Kingdom (UK), EMEA, and Asia Pacific	+44 (0)1329 246 932	emea.service@raymarine.com
United States (US)	+1 (603) 324 7900	rm-usrepair@flir.com

Web support

Please visit the "Support" area of the Raymarine website for:

- **Manuals and Documents** — <http://www.raymarine.com/manuals>
- **FAQ / Knowledgebase** — <http://www.raymarine.com/knowledgebase>
- **Technical support forum** — <http://forum.raymarine.com>
- **Software updates** — <http://www.raymarine.com/software>

Telephone and e-mail support

Region	Telephone	E-mail
United Kingdom (UK), EMEA, and Asia Pacific	+44 (0)1329 246 777	support.uk@raymarine.com
United States (US)	+1 (603) 324 7900 (Toll-free: +800 539 5539)	support@raymarine.com
Australia and New Zealand	+61 2 8977 0300	aus.support@raymarine.com (Raymarine subsidiary)
France	+33 (0)1 46 49 72 30	support.fr@raymarine.com (Raymarine subsidiary)
Germany	+49 (0)40 237 808 0	support.de@raymarine.com (Raymarine subsidiary)
Italy	+39 02 9945 1001	support.it@raymarine.com (Raymarine subsidiary)
Spain	+34 96 2965 102	sat@azimut.es (Authorized Raymarine distributor)
Netherlands	+31 (0)26 3614 905	support.nl@raymarine.com (Raymarine subsidiary)
Sweden	+46 (0)317 633 670	support.se@raymarine.com (Raymarine subsidiary)
Finland	+358 (0)207 619 937	support.fi@raymarine.com (Raymarine subsidiary)

Region	Telephone	E-mail
Norway	+47 692 64 600	support.no@raymarine.com (Raymarine subsidiary)
Denmark	+45 437 164 64	support.dk@raymarine.com (Raymarine subsidiary)
Russia	+7 495 788 0508	info@mikstmarine.ru (Authorized Raymarine distributor)

Viewing product information

The **Getting started** tab contains hardware and software information for your MFD.

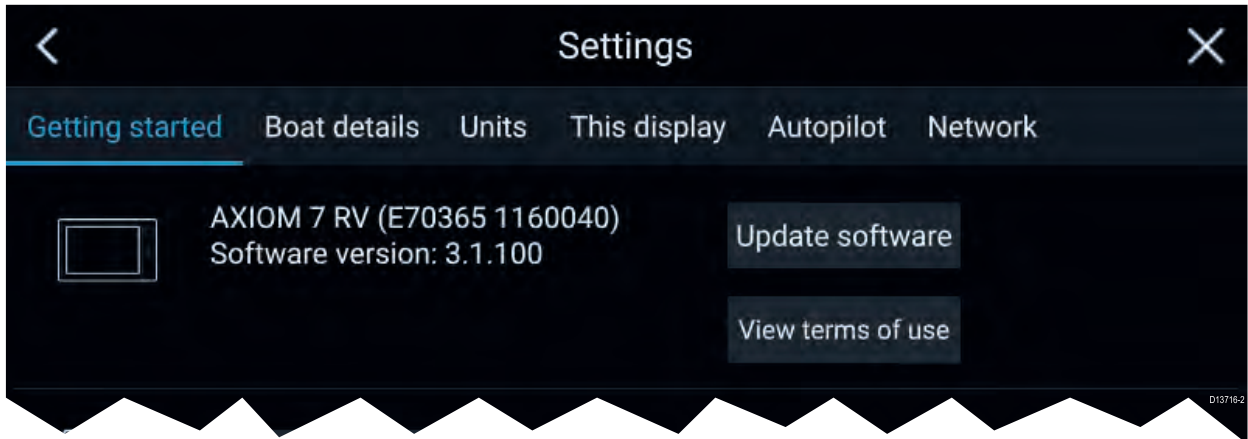

1. Select **Settings**, from the Homescreen.



7.2 Learning resources

Raymarine has produced a range of learning resources to help you get the most out of your products.

Video tutorials

	<p>Raymarine official channel on YouTube:</p> <ul style="list-style-type: none">• http://www.youtube.com/user/RaymarineInc <p>LightHouse 3 video tutorials:</p> <ul style="list-style-type: none">• http://www.raymarine.com/multifunction-displays/light-house3/tips-and-tricks
	<p>Video Gallery:</p> <ul style="list-style-type: none">• http://www.raymarine.co.uk/view/?id=2679
	<p>Product Support videos:</p> <ul style="list-style-type: none">• http://www.raymarine.co.uk/view/?id=4952
<p>Note:</p> <ul style="list-style-type: none">• Viewing the videos requires a device with an Internet connection.• Some videos are only available in English.	

Training courses

Raymarine regularly runs a range of in-depth training courses to help you make the most of your products. Visit the Training section of the Raymarine website for more information:

- <http://www.raymarine.co.uk/view/?id=2372>

FAQs and Knowledge Base

Raymarine has produced an extensive set of FAQs and a Knowledge Base to help you find more information and troubleshoot any issues.

- <http://www.raymarine.co.uk/knowledgebase/>

Technical support forum

You can use the Technical support forum to ask a technical question about a Raymarine product or to find out how other customers are using their Raymarine equipment. The resource is regularly updated with contributions from Raymarine customers and staff:

- <http://forum.raymarine.com>

Chapter 8: Technical specification

Chapter contents

- 8.1 Axiom XL technical specification on page 70
- 8.2 Internal GNSS (GPS / GLONASS) receiver specification on page 72

8.1 Axiom XL technical specification

Power

	Axiom™ XL 16	Axiom™ XL 19	Axiom™ XL 22	Axiom™ XL 24
Nominal supply voltage	12/24 V dc			
Operating voltage range	8 V dc to 32 V dc			
PoE operating voltage range	9.5 V dc to 32 V dc			
Fuse requirements	<ul style="list-style-type: none"> • Inline fuse = 15 Amp, or • Thermal breaker = 15 Amp 			
Maximum current	10 A			
LEN	1			

Environmental

	Axiom™ XL 16	Axiom™ XL 19	Axiom™ XL 22	Axiom™ XL 24
Operating temperature range	-25°C to + 55°C			
Storage temperature range	-30°C to + 70°C			
Humidity	up to 93% @ 40°C			
Water ingress protection	IPx6 and IPx7			
Product weight (MFD only)	5.9 kg	7.6 kg	9.9 kg	11.3 kg

LCD specification

	Axiom™ XL 16	Axiom™ XL 19	Axiom™ XL 22	Axiom™ XL 24
Size (diagonal)	15.6"	18.5"	21.5"	24"
Type	IPS (In-Plane Switching)			
Color depth	24 bit			
Resolution	1920 x 1080 FHD			1920 x 1200 WUXGA
Ratio	16:9			16:10
Illumination	1300 nits / 1300 cd/m ²	1200 nits / 1200 cd/m ²	1500 nits / 1500 cd/m ²	1300 nits / 1300 cd/m ²
Viewing angle	Top 88° / Bottom 88° / Left 88° / Right 88°		Top 89° / Bottom 89° / Left 89° / Right 89°	
Number of simultaneous touches	2			

Data connections

NMEA 2000	1 x DeviceNet male connector
NMEA 0183	2 x NMEA 0183 ports via Power/Video/NMEA 0183 cable: <ul style="list-style-type: none"> • NMEA port 1: Input and output, 4,800 / 38,400 baud rate • NMEA port 2: Input only, 4,800 / 38,400 baud rate

GA150	1 x TNC type external GNSS antenna connection
Alarm / Video 1	<ul style="list-style-type: none"> • 1 x Composite female BNC connector via Alarm / Video 1 connector. • 1 x external Alarm connection via Alarm / Video 1 connector.
Video 2	1 x Composite female BNC connector via Power/Video/NMEA 0183 cable.
Accessory	1 x USB Micro B connection
Network / PoE	3 x RayNet type SeaTalkhs™ connector 10/100 Mbps/s with PoE
HDMI	<ul style="list-style-type: none"> • 1 x HDMI input via HDMI input connector • 1 x HDMI output via HDMI output connector
Touch	<ul style="list-style-type: none"> • 1 x Touch input via Standard USB A Touch in connector • 1 x Touch output via Standard USB B Touch out connector
Wi-Fi	Dual band (2.4 GHz and 5 GHz) 802.11/b/g/n
Bluetooth	Bluetooth V4.0

Storage

Internal	64 GB Solid State
External (via RCR-SDUSB accessory)	<ul style="list-style-type: none"> • 1 x SD card slot • 1 x USB A
External (via RCR-2 accessory)	2 x MicroSDHC card slots

8.2 Internal GNSS (GPS / GLONASS) receiver specification

Channels	Multiple — ability to simultaneously track up to 28 satellites
Cold start	<2 minutes
Receiver IC Sensitivity	<ul style="list-style-type: none"> • 165 dBm (Tracking) • 160 dBm (Acquisition) • 148 dBm (Cold start)
GNSS compatibility	<ul style="list-style-type: none"> • GPS • GLONASS • Beidou* • Galileo*
SBAS compatibility	<ul style="list-style-type: none"> • EGNOS • GAGAN • MSAS • QZSS • WAAS
Operating frequency	1574 MHz to 1605 MHz
Signal Acquisition	Automatic
Almanac Update	Automatic
Geodetic Datum	WGS-84 (alternatives can be selected on the MFD)
Refresh Rate	10 Hz (10 times per second)
Antenna	<ul style="list-style-type: none"> • External — An external passive antenna is required
Position Accuracy	<ul style="list-style-type: none"> • Without SBAS: <= 15 metres 95% of the time • With SBAS: <= 5 metres 95% of the time

Note: * Supported in future software update.

Chapter 9: Spares and accessories

Chapter contents

- [9.1 AXIOM XL accessories on page 74](#)
- [9.2 AXIOM XL spares on page 75](#)
- [9.3 RayNet to RayNet cables and connectors on page 76](#)
- [9.4 SeaTalkng[®] cables and accessories on page 78](#)

9.1 AXIOM XL accessories

Part number	Description
A80440	RCR-SDUSB — External MicroSD and USB reader
A80438 / T70293	RMK-10 — MFD remote control
A80288	GA150 — passive GNSS (GPS) antenna
A80578	Touch in — USB A to USB B 5 m (16.4 ft) cable
A80579	Touch out — USB B to USB A 5 m (16.4 ft) cable
A80219	HDMI cable 5 m (16.4 ft) cable
A80235	Alarm / Video cable 2 m (6.56 ft)

9.2 AXIOM XL spares

Item	Part numbers
Power/Video/NMEA 0183 cable 1.5 m (4.9 ft)	R62379
Angled Power/Video/NMEA 0183 cable 1.5 m (4.9 ft) with right angled connector	R70029
Suncover	<ul style="list-style-type: none">• Axiom™ XL 16: R70665• Axiom™ XL 19: R70666• Axiom™ XL 22: R70676• Axiom™ XL 24: R70667
Rear mounting kit	<ul style="list-style-type: none">• Axiom™ XL 16: R70668• Axiom™ XL 19: R70669• Axiom™ XL 22: R70675• Axiom™ XL 24: R70670

9.3 RayNet to RayNet cables and connectors

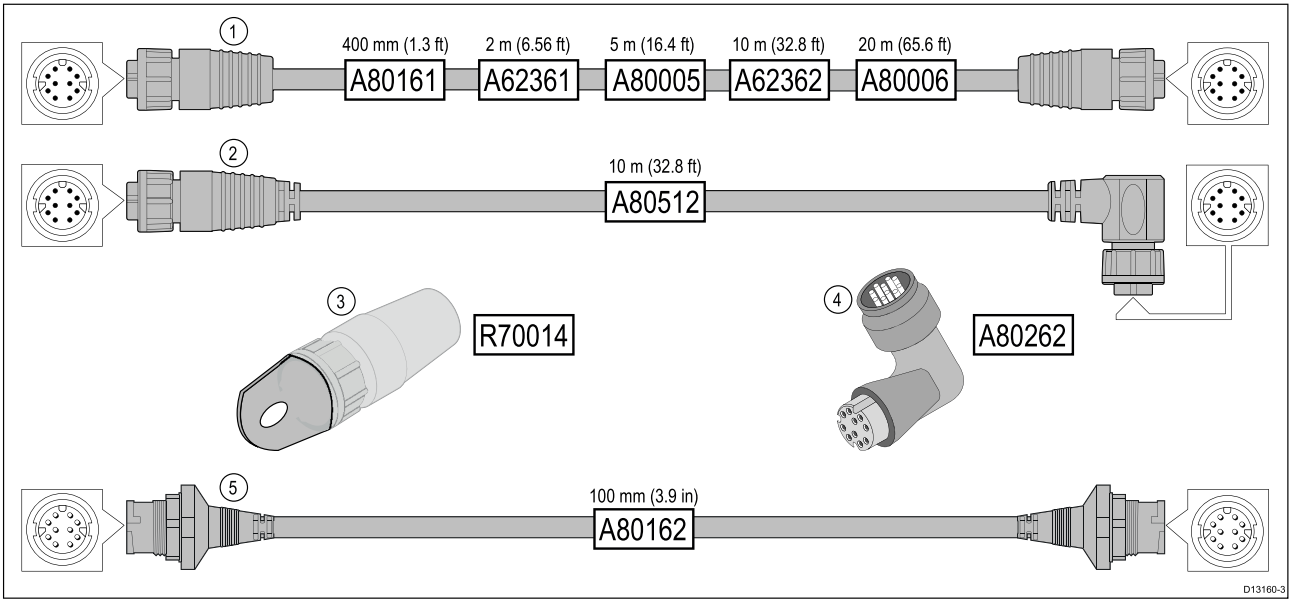

	Description
1	Standard RayNet connection cable with a RayNet (female) socket on both ends.
2	Right-angle RayNet connection cable with a straight RayNet (female) socket on one end, and a right-angle RayNet (female) socket on the other. Suitable for connecting at 90° (right angle) to a device, for installations where space is limited.
3	RayNet cable puller (5 pack).
4	RayNet to RayNet right-angle coupler / adapter. Suitable for connecting RayNet cables at 90° (right angle) to devices, for installations where space is limited.
5	Adapter cable with a RayNet (male) plug on both ends. Suitable for joining (female) RayNet cables together for longer cable runs.

RayNet to RJ45 adapter cables

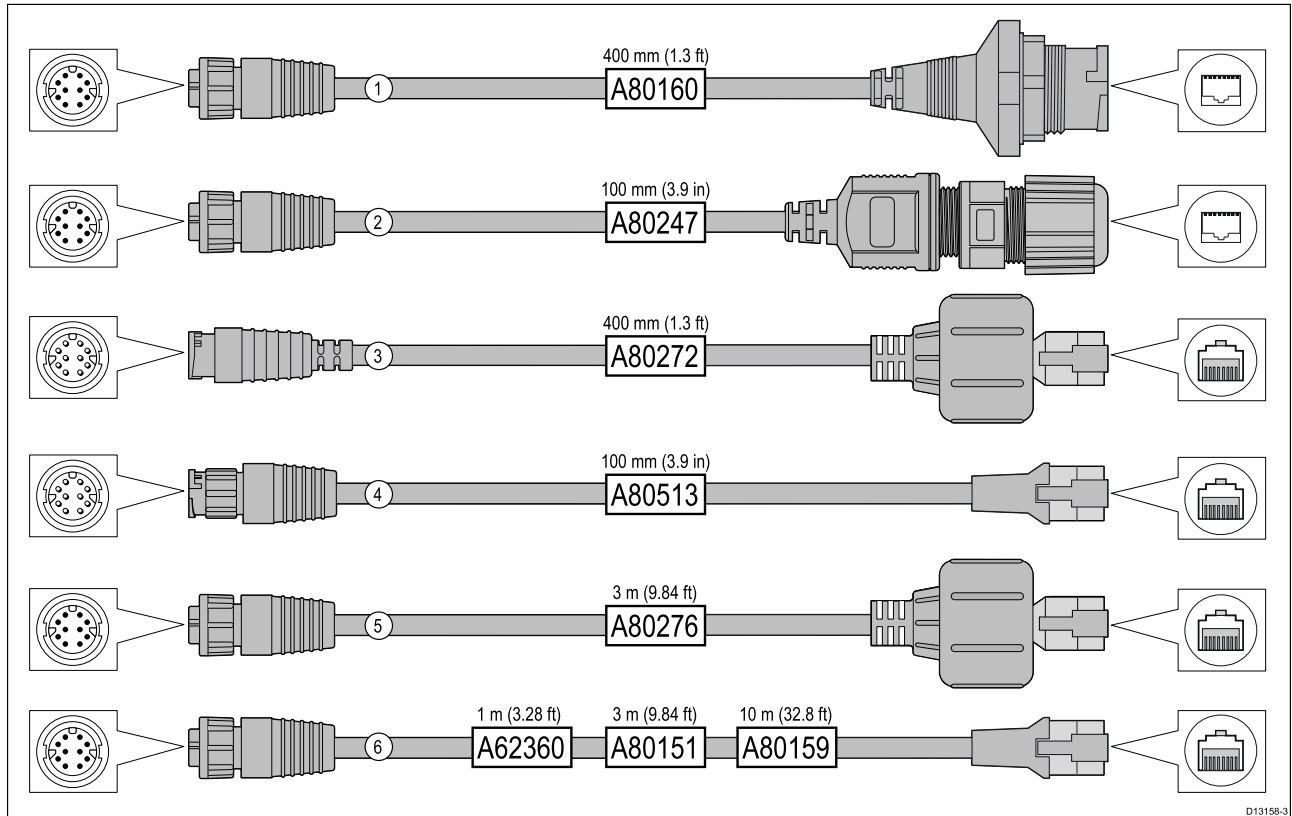

	Description
1	Adapter cable with a RayNet (female) socket on one end, and a waterproof (female) socket on the other end accepting the following cables with an RJ45 SeaTalk^{hs} waterproof locking (male) plug: <ul style="list-style-type: none"> • A62245 (1.5 m). • A62246 (15 m).
2	Adapter cable with a RayNet (female) socket on one end, and a waterproof (female) RJ45 socket on the other end, along with a locking gland for a watertight fit.
3	Adapter cable with a RayNet (male) plug on one end, and an RJ45 SeaTalk^{hs} waterproof (male) plug on the other end.
4	Adapter cable with a RayNet (male) plug on one end, and an RJ45 SeaTalk^{hs} (male) plug on the other end.
5	Adapter cable with a RayNet (female) socket on one end, and an RJ45 SeaTalk^{hs} waterproof (male) plug on the other end.
6	Adapter cable with a RayNet (female) socket on one end, and an RJ45 SeaTalk^{hs} (male) socket on the other end.

9.4 SeaTalkng[®] cables and accessories

SeaTalkng[®] cables and accessories for use with compatible products.

Part No	Description	Notes
T70134	Starter kit	Includes: <ul style="list-style-type: none"> • 1 x 5 Way connector (A06064) • 2 x Backbone terminator (A06031) • 1 x 3 m (9.8 ft) spur cable (A06040) • 1 x Power cable (A06049)
A25062	Backbone Kit	Includes: <ul style="list-style-type: none"> • 2 x 5 m (16.4 ft) Backbone cable (A06036) • 1 x 20 m (65.6 ft) Backbone cable (A06037) • 4 x T-piece (A06028) • 2 x Backbone terminator (A06031) • 1 x Power cable (A06049)
A06038	Spur cable 0.4 m (1.3 ft)	
A06039	Spur cable 1 m (3.3 ft)	
A06040	Spur cable 3 m (9.8 ft)	
A06041	Spur cable 5 m (16.4 ft)	
A06042	Elbow spur cable 0.4 m (1.3 ft)	
A06033	Backbone cable 0.4 m (1.3 ft)	
A06034	Backbone cable 1 m (3.3 ft)	
A06035	Backbone cable 3 m (9.8 ft)	
A06036	Backbone cable 5 m (16.4 ft)	
A06068	Backbone cable 9 m (29.5 ft)	
A06037	Backbone cable 20 m (65.6 ft)	
A06043	SeaTalkng [®] to bare wire spur cable 1 m (3.3 ft)	
A06044	SeaTalkng [®] to bare wire spur cable 3 m (9.8 ft)	
A06049	Power cable 1 m (3.3 ft)	
A06077	Right angled connector	90° right angle spur connector.
A06031	Terminator	
A06028	T-piece	Provides 1 x spur connection
A06064	5-way connector block	Provides 3 x spur connections
A06030	Backbone extender	
E22158	SeaTalk to SeaTalkng [®] converter kit	Allows the connection of SeaTalk devices to a SeaTalkng [®] system.
A80001	Inline terminator	Provides direct connection of a spur cable to the end of a backbone cable. No T-piece required.
A06032	Spur blanking plug	
R12112	ACU / SPX SeaTalkng [®] spur cable 0.3 m (1.0 ft)	Connects an SPX course computer or an ACU to a SeaTalkng [®] backbone.
A06047	SeaTalk (3 pin) to SeaTalkng [®] adaptor cable 0.4 m (1.3 ft)	

Part No	Description	Notes
A22164	SeaTalk to SeaTalkng [®] spur cable 1 m (3.3 ft)	
A06048	SeaTalk2 (5 pin) to SeaTalkng [®] adaptor cable 0.4 m (1.3 ft)	
A06045	SeaTalkng [®] to DeviceNet (Female) adaptor cable 0.4 m (1.3 ft)	Allows the connection of NMEA 2000 devices to a SeaTalkng [®] system.
A06075	SeaTalkng [®] to DeviceNet (Female) adaptor cable 1 m (3.3 ft)	Allows the connection of NMEA 2000 devices to a SeaTalkng [®] system.
A06046	SeaTalkng [®] to DeviceNet (Male) adaptor cable 1.5 m (4.92 ft)	Allows the connection of NMEA 2000 devices to a SeaTalkng [®] system.
A06076	SeaTalkng [®] to DeviceNet (Male) adaptor cable 1 m (3.3 ft)	Allows the connection of NMEA 2000 devices to a SeaTalkng [®] system.
A06078	SeaTalkng [®] to DeviceNet (Male) adaptor cable 0.1 m (0.33 ft)	Allows the connection of NMEA 2000 devices to a SeaTalkng [®] system.
E05026	DeviceNet (Female) to bare wires adaptor cable (0.4 m (1.3 ft)	Allows the connection of NMEA 2000 devices to a SeaTalkng [®] system.
E05027	DeviceNet (Male) to bare wires adaptor cable (0.4 m (1.3 ft)	Allows the connection of NMEA 2000 devices to a SeaTalkng [®] system.

Index

A

Accessories	74
Network adapter cables	77
Network cables	76
RayNet cables	76
Accessory connection	42
Additional components	15
Alarm connection	41
Axiom™ XL MFDs	15

C

Card reader connection	42
Cleaning	51
Screen	51
Compass safe distance	19
Connecting cables	29
Connections	28
Accessory	28, 42
Alarm	28
Analog camera	47–48
Analog video	47–48
Battery	31
Card reader	42
Distribution panel	32
Ethernet	37
External storage	42
GA150	28, 40
Ground	28
HDMI	28
HDMI in	43, 46
HDMI out	44–45
Network	37
NMEA 0183	28, 36
NMEA 2000	28, 35
Optional Grounding	34
PoE	39
Power	28, 30
RayNet	28, 37
RCR	42
Remote MFD alarm buzzer	41
SeaTalkhs	37
SeaTalkng	35
Touch	28
Touch in	45
Touch out	46
USB	28
Video	28
Video 1	47
Video 2	48
Connectors	28
Contact details	66

D

Declaration of Conformity	11
Dedicated grounding	34
DeviceNet cables	79

E

Electromagnetic Compatibility	18
EMC, <i>See</i> Electromagnetic Compatibility	
Ethernet connection	37
External storage connection	42

F

Factory reset	55
Fuse rating	30

G

GA150 connection	40
GNSS antenna connection	40
GPS antenna connection	40

H

HDMI in connection	43, 46
HDMI out connection	44–45

I

Installation	
Best practice	33
Flush mounting	24
Mounting options	22
Surface mounting	24
Interference	19
<i>See also</i> Compass safe distance	
RF	19

L

LightHouse 3	14
Location requirements	
General	18
GNSS	19
GPS	19
Touchscreen	20
Viewing angle	20
Wireless	20

M

Maintenance	50
Mounting surface requirements	9, 18

N

Network connection	37
NMEA 0183	
Baud rate	36
NMEA 0183 connection	36
NMEA 2000 connection	35

O

Operation instructions, LightHouse 3	14
--	----

P

Parts supplied	
----------------	--

Axiom XL.....	16
PoE connection	39
PoE device class.....	38
Power	
Battery connection.....	31
Distribution	30
Distribution panel.....	32
Grounding.....	33
Sharing a breaker	32
Power cable extension	33
Power connection	30
Power over Ethernet (PoE)	38
Power troubleshooting	55
Product dimensions.....	21
Product support.....	66
Product variants.....	15

R

Radio Frequency (RF) interference.....	19
RayNet	
cables	76–77
RayNet connection	37
RCR-SDUSB.....	14
Recovery mode	55
Routine checks	50

S

SeaTalkhs connection	37
SeaTalkng cables	78
SeaTalkng connection.....	35
Service Center.....	66
Servicing.....	50
Spares	75
Suppression ferrite	37

T

Technical specification	69
Technical support.....	66
Touch in connection.....	45
Touch out connection.....	46
Troubleshooting	54
GNSS	56

V

Ventilation	18
Video connection	47–48

W

Warranty	66
WEEE Directive.....	11
Wireless	
Interference	20



Raymarine

Marine House, Cartwright Drive, Fareham, Hampshire.
PO15 5RJ. United Kingdom.

Tel: +44 (0)1329 246 700

www.raymarine.com

Raymarine®

a brand by  **FLIR®**