

EPIRB1 Pro Float-Free Category 1 EPIRB

Communication and Safety at Sea

The SafeSea EPIRB1 Pro operates in the 406MHz satellite band. This band comprises the international distress frequencies that are constantly monitored by Cospas-Sarsat, the international search and rescue satellite operator, ensuring a rapid response when a signal is received, no matter where it is in the world.

- Complies with MED (2014/90/EU)
- 406 MHz (link via satellite to emergency services)
- 121.5 MHz Homing Signal (to aid final locating by search & rescue)
- High Intensity Strobe
- 30% (typ) Smaller
- 10 year Battery Life
- 2 Year Warranty
- 66 Channel GPS (fact accurate positioning)



Specification

Transmitter

Satellite Transmission	406.040 MHz ^(12W Max. EIRP)
Homing Transmission	121.5 MHz ^(50mW nominal)
GPS	Internal GPS ^(66 Channel)

Components

Strobe	LED Strobe
Battery	Class 2 Lithium Battery (non-hazmat / LiMnO2)
Battery Replacement Interval	10 Years
Waterproof	33 ft (10 m) for 1 hour
Operational Life	48 Hours minimum @ -4°F (-20°C)
Operating Temp.	4°F to +131°F (-20°C to +55°C) (Class 2)
Limited Warranty	2 Years

Category I Automatic Release Housing (ARH)

ARH Release Depth	13 ft. (4m) Maximum
ARH Dimensions	9.3" x 7.5" x 4.8" (237mm x 191mm x 121mm)

Approvals
 MED & Cospas-Sarsat
 Pending: FCC, USCG, IC, AMSA, CCS

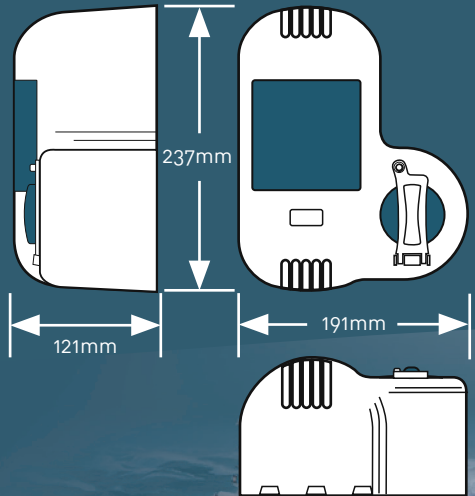

EPRIB1 Pro Dimensions

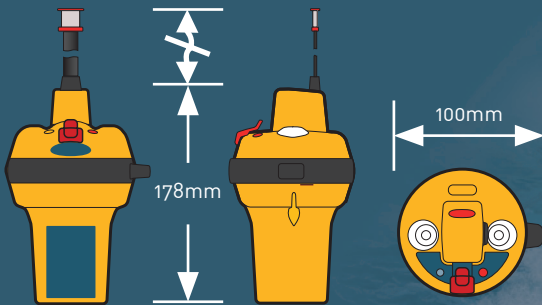

This device has not been authorized as required by the rules of the FCC. This device is not, and may not be offered for sale or lease, or sold or leased, until authorization is obtained.

