

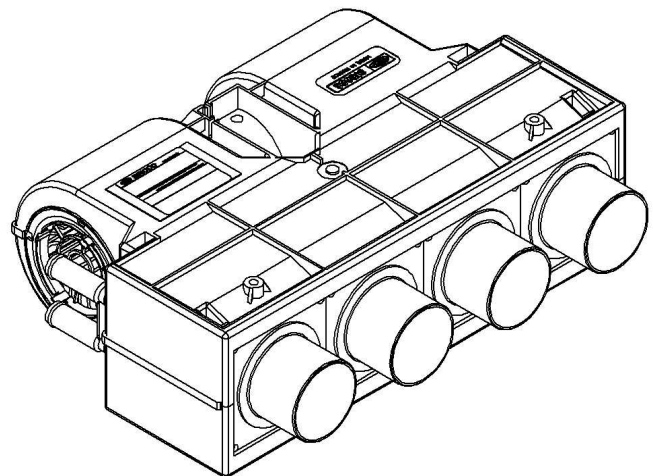

# SAHARA B-C-D-F-H-I

- 1 - Device description**
- 2 - Operation**
- 3 - Mounting information**
- 4 - Trouble shooting**
- 5 - Security advice**



SIROCO S.A.S.  
10 rue Jean Rostand - Z.I.  
BP 315  
69745 GENAS Cedex  
Tel: +33 (0)4 78 90 96 96  
Fax: +33 (0)4 78 90 15 98  
[www.siroco.fr](http://www.siroco.fr)



## 1 - Device description

SAHARA heater consist of a blower, a coil and two plastic parts. Plastic parts are made from heat and impact resistant ABS. Heater can operate under three different speeds: four electrical wires have to be connected. There are input-output cooling water supply and input-output air supply.

Nine versions are available : B - C - D - F - H and I versions which front side is different.

All versions are available in 12 V or 24 V with connections pipes diameters of 14 mm or 16 mm, also of 19 mm to C version.

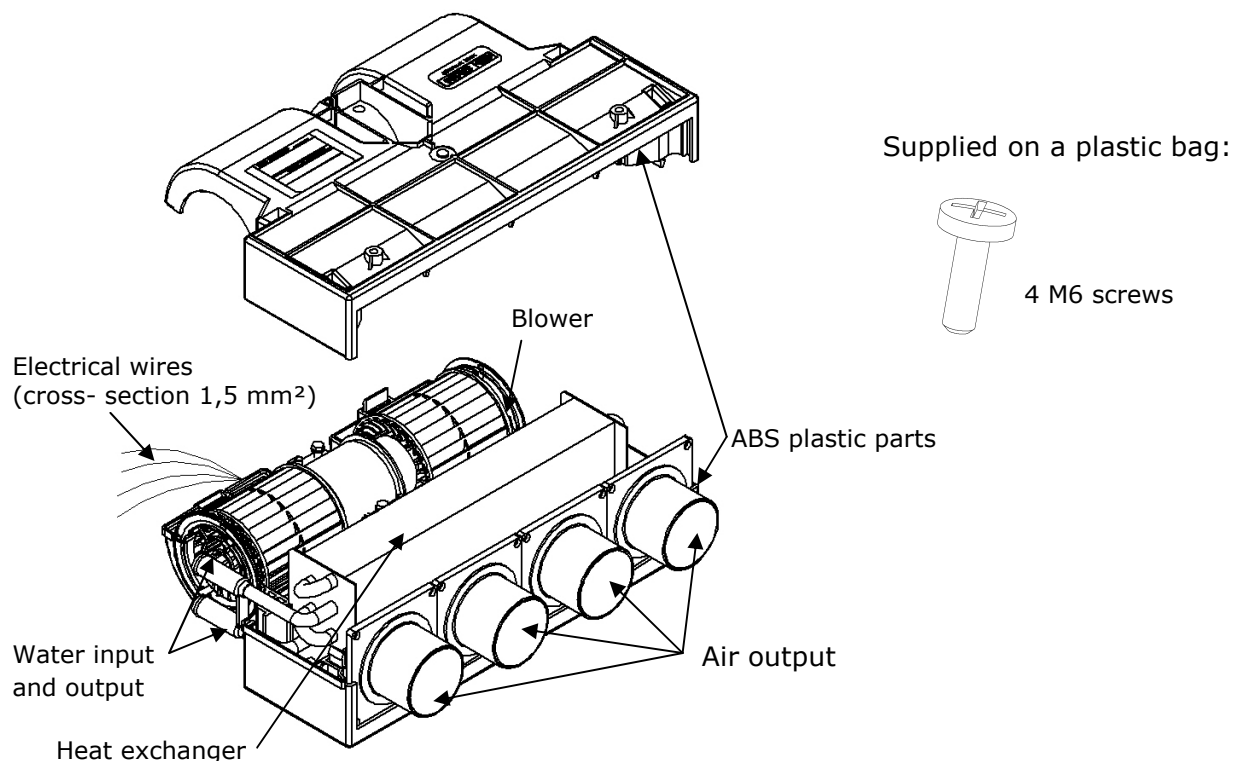

### Product part numbers:

Voltage	Pipes Ø (mm)	SAHARA B	SAHARA C	SAHARA D Ø40	SAHARA D Ø45	SAHARA D Ø50	SAHARA D Ø55	SAHARA D Ø60
		Part number	Part number	Part number	Part number	Part number	Part number	Part number
12 V	Ø 14	0170 1001	0170 1011	0170 1021	0170 1023	0170 1025	0170 1027	0170 1020
	Ø 16	0170 2003	0170 2013	0170 2023	0170 2025	0170 2027	0170 2029	0170 2021
	Ø 19	-	0170 3002	-	-	-	-	-
24 V	Ø 14	0170 1002	0170 1012	0170 1022	0170 1024	0170 1026	0170 1028	0170 1029
	Ø 16	0170 2004	0170 2014	0170 2024	0170 2026	0170 2028	0170 2030	0170 2022
	Ø 19	-	0170 3003	-	-	-	-	-

Voltage	Pipes Ø (mm)	SAHARA F	SAHARA H	SAHARA I
		Part number	Part number	Part number
12 V	Ø 14	0170 1035	0170 1050	0170 1060
	Ø 16	0170 2040	0170 2050	0170 2060
24 V	Ø 14	0170 1036	0170 1051	0170 1061
	Ø 16	0170 2041	0170 2051	0170 2061



## 2 - Operation

Cooling water, beforehand heated by the vehicle, run on coil. In the same time, fan unit blows fresh air through the heat exchanger. Then, air temperature rise up. Finally, air output evacuate hot air.

### Operating conditions:

Product must be on a ventilated place.

Operating temperature have to be between -30°C and +80°C.

Cooling fluid must be antifreeze and anticorrosive for copper and aluminum. Use a cooling fluid officially recognize by automotive manufacturers.

### Technical data:

Voltage	Electrical power	Weight	Nominal air flow	Heating capacity
12/24 V	150 W	3,1 kg	320 m <sup>3</sup> /h	8,6 kW

Optimum heating capacity is reached with air inlet temperature of 0°C, nominal air flow of 0,5 m<sup>3</sup>/h, free ethylene glycol water and water inlet temperature of 100°C.

## 3 - Mounting information

- 1** Fix product on its stand with 4 supplied screws (M6). Blower motor axis should rather be in horizontal position on the vehicle.

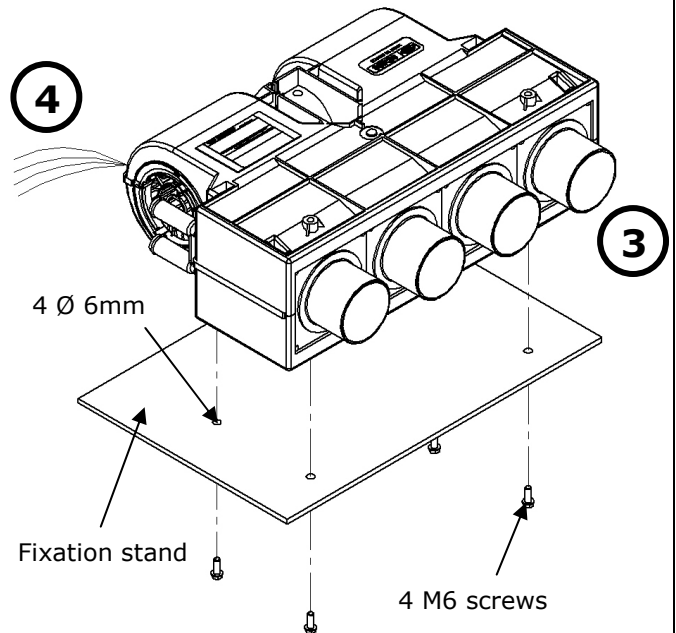
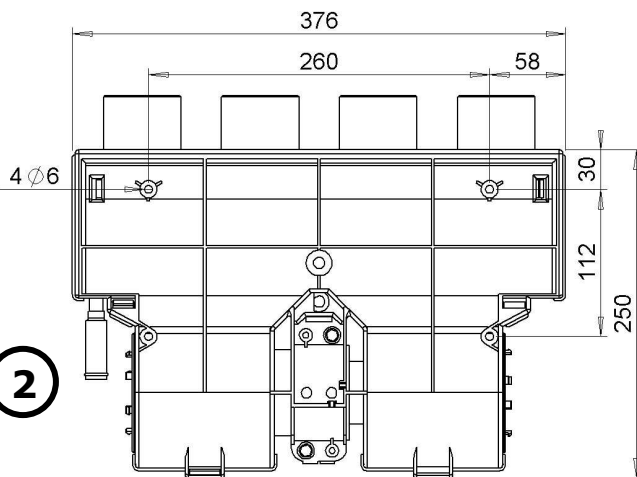
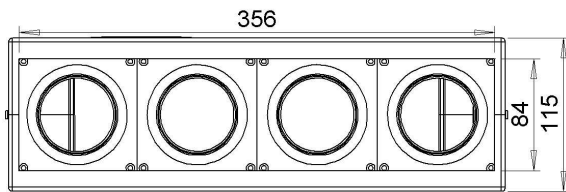

Do not drill heater's body so as not to damage heat exchanger !



- 2
3
 Connect water input and output using cooling pipes with corresponding diameter (cf. product part number §1). Using suitable clamping rings. There is no preferential cooling water direction.

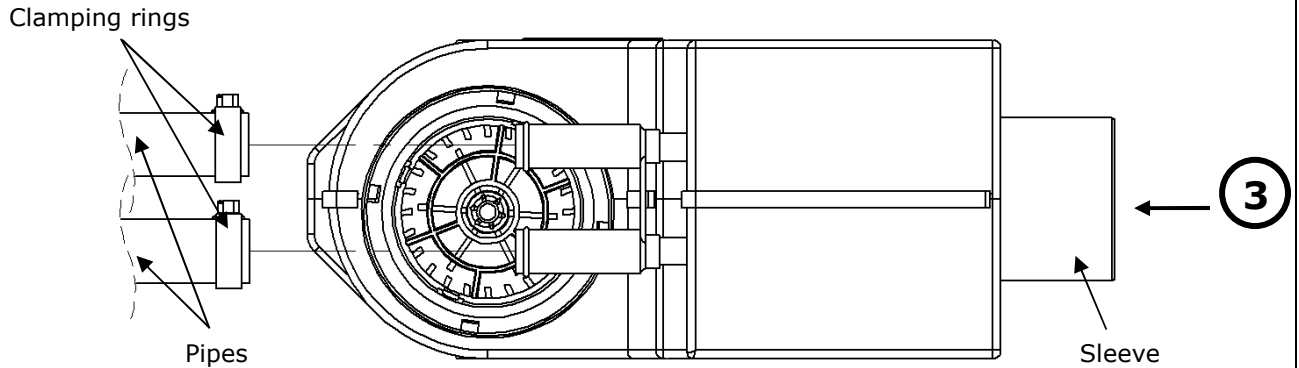

Check for leaks in water.

- 3
 About D, H and I versions, put sheaths on sleeves. Make sure the system is airtight by using clamping rings.

Check for leaks in air.

- 4
 Connect electrical wires according to the following circuit diagram. Use at least 1,5 mm<sup>2</sup> cable cross-section.

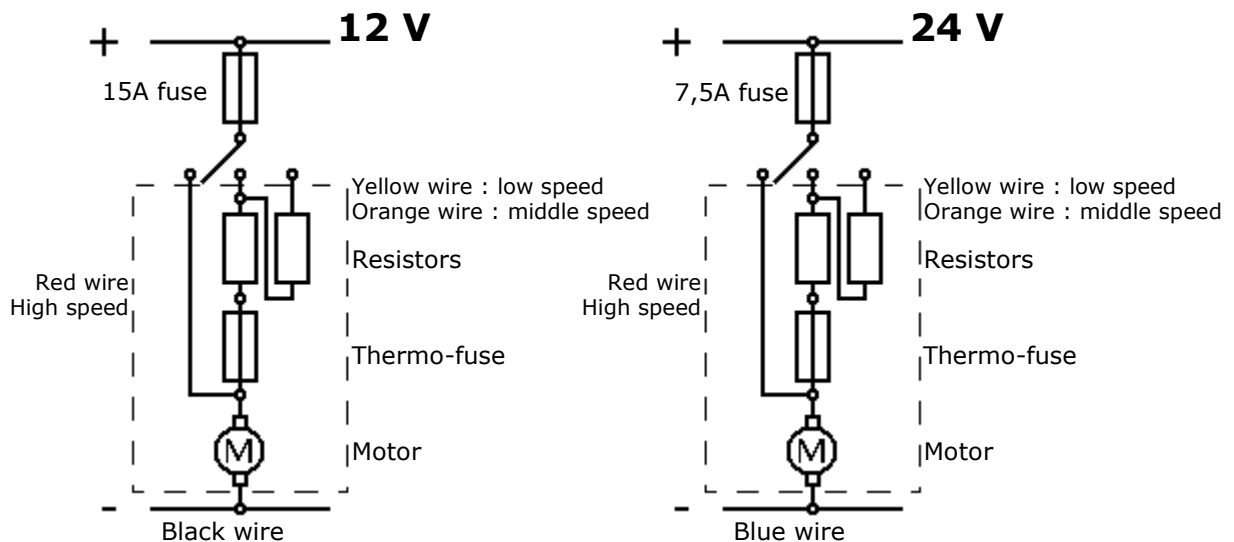

Heater

**4 - Trouble shooting**

<b>Fault found</b>	<b>Possible cause</b>	<b>Action to take</b>
Blower not working	Fuse defective	Check fuse position and amperage. If necessary replace it. Before renew a fuse, always identify causes. Examine blowers for a blockage or another type of defect and rectify the cause.
	No vehicle power	Switch on ignition and/or main battery switch.
		Check battery connections.
		Check vehicle operating instructions for possible advice.
	Connecting cable damaged or torn out	Replace cable. Check for correct cable routing and connections according to the circuit diagram.
	Electrical connections reversed	Check connecting wires according to the circuit diagram and if necessary assemble correctly.
	Blower switch defective	Replace the switch with a new original component.
	Blockage in fan unit	Rectify cause of blockage, e.g. object in impeller. If necessary order new unit.
Blower motor defective	Replace plastic part + motor.	
Blower doesn't operate at all speeds	No blower power	Check connection on blower switch.
	Defective resistance	Replace plastic part + motor.
Blower only runs at low and middle speed	Fuse defective	Replace fuse.
Unit cannot be switched off	Short-circuit in cable	Rectify circuit diagram. If necessary, install new cable.
Blower only operate at reduced power	Rated voltage is wrong	Rated voltage of unit and on-board circuit must be the same. Order new unit.
	Air nozzles closed or covered	Open nozzles or free up inlet/outlet openings.
	Electrical wires are underdimensioned	Install recommended cable cross-section.
	Heat exchanger severely contaminated	Carefully clean avoiding damage which can lead to leaks. <b>WARNING!</b> Observe safety instructions.
Heating doesn't function	Vehicle engine is not running	Start engine.
	Cooling water still cold	Wait until the engine reaches operating temperature
	Water valve closed	See the vehicle manufacturer's operating instructions.
	Water lines kinked or squashed	Eliminate fault by installing correctly.
	Water pump pressure insufficient	Heat exchanger does not have cooling water flowing through. Install additional pump or more powerful one.
Reduced heating performance	Volumetric air flow from blower is too low	See action to take under "Blower"
	Water flow rate through heat exchanger is too low	Water lines kinked or squashed. Relay hoses. Water pump pressure too low (see above for action).
	Air in heat exchanger	Flush-out water circuit.
		When the pumping pressure is sufficient the heater is self bleeding. Install additional or more powerful water pump.
	Unit is underdimensioned	Install a more powerful unit.
	Insufficient pumped water pressure	Install additional pump or a more powerful one.
	Heat exchanger severely contaminated	Carefully clean avoiding damage which can lead to leaks.



Products which have already been pulling appart are not covered by guaratee.



## 5 - Security advice

Consider the following advice for your own safety :

- Installation must only be done by well-formed and authorized specialists.
- Product must operate on a well-ventilated place.
- Products have to be used only according to the intended use. Products shall not be used in improper environment. Pay attention to guarantee.
- Before using products, ensure that regulations and laws are strictly adhered according to the country.
- For security reasons (fire hazards), fuses with required amperage must be used to protect electrical connections.
- Cut electrical connections before working on product.
- Do not get into contact with the heat exchanger and its connections.
- Do not grip into the unit and do not put objects inside.