



DUFOUR
YACHTS

OWNER'S MANUAL



YACHT DESIGN CATEGORY: A

COMPLIANT WITH EUROPEAN DIRECTIVE 2013-53-EU

This page intentionally left blank.

This page intentionally left blank.

This page intentionally left blank.

Your agent:

Surname

is the **DUFOUR YACHTS** representative and will give you all the help you need to solve any difficulties you might have during the launching and masting of your boat, as well as for commissioning and maintenance technical checks. If necessary, he will help you with the administrative process of registering your boat.

As soon as you become the owner, familiarize yourself with the manual supplied with your boat, sign and date the receipt acknowledgements below, and give (or send) the last one to your agent.

Acknowledgement of receipt of the Owner's Manual. Owner's copy to be kept in your Manual

I, the undersigned:

Name

Address

owner of DUF0UR 430 No.

confirm that I have received the DUF0UR 430 Owner's Manual and accept that it is written in the English language.

Dated:

Signature:

Detach along dotted line

✂.....

Owner's Manual receipt acknowledgement to be returned to DUF0UR YACHTS

11, Rue Blaise Pascal- 17187 PERIGNY CEDEX- FRANCE

I, the undersigned:

Name

Address

owner of DUF0UR 430 no.

confirm that I have received the DUF0UR 430 Owner's Manual and accept that it is written in the English language.

Dated:

Signature:

This page intentionally left blank.

This page intentionally left blank.

This page intentionally left blank.

CONTENTS

<i>INTRODUCTION</i>	7
<i>I. GENERAL INFORMATION</i>	8
Yacht design category _____	8
Certification _____	8
Identification _____	8
Builder's plate _____	9
Degrees of danger _____	9
<i>II. PRINCIPAL SPECIFICATIONS</i>	10
<i>These values are those of the deep-keel version with a standard mast.</i>	11
<i>III. ELECTRICAL SYSTEMS</i>	12
Safety and operating instructions for the electrical system _____	12
Fitting new equipment _____	12
Batteries _____	13
Electric windlass _____	13
Ins 220/110 Volt installation (ISO 13297: 2000) _____	14
<i>IV. GAS INSTALLATION</i>	15
General Information _____	15
<i>V. DRAIN & SANITATION SYSTEM</i>	17
Characteristics of the drain system (ISO 15083: 2003) _____	17
Pressurized fresh-water pump _____	17
Seacocks _____	18
Operation of the sea toilets _____	18
Holding tank operation (ISO 8099:2000) _____	18
<i>VI. FLOODING</i>	19
<i>VII. FIRE PROTECTION</i>	19
Installation _____	19
Safety Instructions _____	20
<i>VIII. ENGINE</i>	21
General precautions _____	21
Exhaust gas emission _____	21
Safety _____	21
Wintering _____	22
<i>IX. FUEL INSTALLATION</i>	22
<i>X. HELM SYSTEM</i>	22
Helm _____	22
Emergency tiller _____	23
<i>XI. SAILING</i>	24
<i>XII. FALL PREVENTION AND MEANS OF GETTING BACK ABOARD</i>	25
<i>XIII. LIGHTNING PROTECTION</i>	26
Maintenance _____	26
Personal protection during thunderstorms _____	26
<i>XIV. ENVIRONMENTAL PROTECTION & SAFETY</i>	26
<i>XV. SAFETY FACILITIES</i>	27
<i>XVI. HANDLING, TRANSPORTING, HAUL-OUT</i>	27
<i>XVII. MOORING, ANCHORING, AND TOWING</i>	28
Responsibility _____	28
<i>XVIII. GUARANTEE, TRANSFER OF OWNERSHIP</i>	29
1. <i>Presentation</i>	34

2.	<i>Accommodation layout</i>	35
3.	<i>Deck fittings layout</i>	38
4.	<i>Sail plan</i>	40
5.	<i>Running rigging, sheets and halyards layout</i>	42
6.	<i>220V circuit diagram</i>	47
7.	<i>Charging and power system diagram</i>	49
8.	<i>12V electric panel</i>	51
9.	<i>Electrical panel rear wiring</i>	53
10.	<i>12V electrical installation diagram</i>	57
11	<i>220V electrical installation diagram</i>	60
12	<i>Fuse location diagram</i>	63
13	<i>Steering system diagram</i>	66
14	<i>Gas system diagram</i>	68
15	<i>Abandon ship plan</i>	71
16-	<i>Freshwater system diagram</i>	74
17	<i>Drain system diagram</i>	77
18	<i>Skin fitting location diagram</i>	79
19	<i>Mechanical installation diagram</i>	82
20	<i>Gas system diagram</i>	84
21	<i>Holding tank installation diagram</i>	86
22	<i>Lifting diagram</i>	88
23	<i>Navigation lights</i>	90

INTRODUCTION

DUFOUR YACHTS is pleased to present you with this manual, which will help you get to know your boat better.

This Manual has been produced to help you use your boat safely and enjoyably. It contains details of the boat, the equipment supplied or fitted, its systems and information about their use. Read it carefully and familiarize yourself with the boat before using it.

This Owner's Manual is not a course in sailing safety or seamanship. If this is your first boat or you are changing to a type of boat you are unfamiliar with, for your convenience and safety, make sure you gain experience in handling and using it before taking command. Your agent, national sailing or cruising federation or yacht club will be happy to give you information about sailing schools or qualified instructors in your area.

Ensure that forecast wind and sea conditions correspond to the design category of your boat, and that you and your crew are capable of handling the boat in these conditions. Even when your boat is suitable for them, the sea and wind conditions corresponding to design categories A, B, and C vary from severe storm for category A to severe conditions for the top end of category C, subject to dangers of abnormal gusts or waves; these are dangerous conditions in which only an experienced, trained crew in good shape, sailing a properly-maintained boat, can sail in a satisfactory manner.

This Owner's Manual is not a detailed maintenance or repair guide. In the event of problems, consult the boatbuilder or their representative. If a maintenance manual is provided, be sure to use it.

Always employ the services of an experienced professional for maintenance, fitting accessories, or modifications. Modifications that could affect the characteristics of the boat must be assessed, performed and documented by qualified personnel. The boatbuilder cannot be held responsible for modifications made without their approval.

In certain countries, a skipper's license or some form of authorization is required, or special rules and regulations are applicable.

Always maintain your boat correctly and make allowances for deterioration due to age or resulting, where applicable, from heavy or unsuitable use. Any boat, however sturdy, can be severely damaged if it is used incorrectly. This is incompatible with safe sailing. Always suit your speed and heading to the prevailing sea conditions.

If your boat is equipped with a life raft, read its instruction manual carefully. The crew must have all the safety equipment on board (life-jackets, harnesses, etc.), corresponding to the type of boat, weather conditions, etc. In some countries, this equipment is mandatory. The crew must be familiar with the use of all the safety equipment and the emergency safety procedures (man overboard recovery, towing, etc.); training sessions are regularly organized by sailing schools and clubs.

It is recommended that all persons wear appropriate buoyancy aids (life-jackets, personal flotation devices) when on deck. It should be noted that in certain countries, it is compulsory to wear a buoyancy aid (complying with national regulations) at all times.

KEEP THIS MANUAL IN A SAFE PLACE AND PASS IT ON TO THE NEW OWNER IF YOU SELL THE BOAT.

NOTICE: *Our boats are regularly improved in light of our customers' experiences and research carried out by the shipyard. As a result, the specifications given in this Owner's Manual are not contractually binding and may be changed without notice and without any obligation to update them. This manual is intended to cover as much information as possible, so certain equipment or paragraphs might not apply to your boat. In case of doubt, please refer to the inventory which should have been given to you by your agent when you placed your order.*

I. GENERAL INFORMATION

Yacht design category

Your DUF40UR 430 enters into design category **OCEAN** (category A).

Under normal conditions of use, your boat is designed to sail in waves of a significant height over 4 m, winds of Beaufort force 8 and above, and to resist under more severe conditions.

This navigational capacity also depends on the skill of the crew, their physical capacity, boat maintenance and equipment.

So always take care before putting to sea.

DUF40UR YACHTS is not able to guarantee perfect functioning of the boat in exceptional sea conditions (violent storms, hurricanes, cyclones, waterspouts, etc.)

SUMMARY OF DESIGN CATEGORIES

Categories Design	Wind strength (Beaufort)	Wind speed	Significant wave height to be taken into account
A	Above 8	Up to 28 m/s	Above 4 m
B	Up to 8	Up to 21m/s	Up to 4 m inclusive
C	Up to 6	Up to 17 m/s	Up to 2 m inclusive
D	Up to 4	Up to 13 m/s	Up to 0.5 m inclusive

Check the weather forecast before putting to sea: **take to the sea, but don't take any risks!**

In port: every day, the Harbour Master's Office posts weather bulletins and forecasts for the next few days.

Météo France on 08 36 68 08 08

Navifax - direct on 08 36 70 18 52

VHF: CROSS transmits several bulletins per day, preceded by an announcement on Channel 16.

Certification

DUF40UR YACHTS has chosen Institut pour la **Certification et la Normalisation dans le Nautisme** (ICNN) as the notified body (0607) to check the conformity of the Dufour 430 series with European Directive CE 2013-53-EU, under module B.

Identification

The hull identification number is located on the starboard side of the transom. It contains a series of letters and numbers that begin with FR-DUF...

Builder's plate

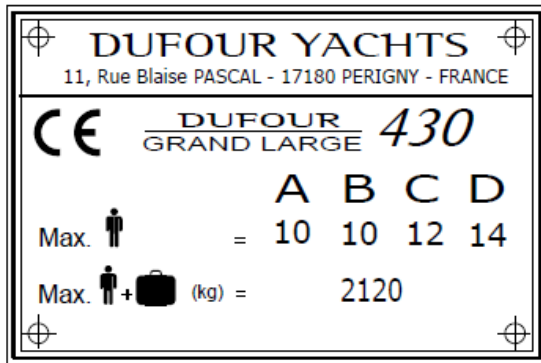

Some of this information is provided on the builder's plate attached to the boat. A full explanation of this information is given below.

Yacht design category = **A** : (see 1.1)

Max. number of people:



Category A = **10**
 Category B = **10**
 Category C = **12**
 Category D = **14**

: recommended by the builder when the boat sails under sea conditions that correspond to its design category.

WARNING

Do not exceed the maximum recommended number of people. However, many people there are aboard, the total weight of the people and equipment must never exceed the maximum recommended load.

Max recommended load:



Category A = **2120 kg**
 Category B = **2120 kg**
 Category C = **2120 kg**
 Category D = **2120 kg**

: recommended by the manufacturer including the weight of all passengers aboard, provisions and personal belongings, in addition to all equipment not included in the boat's light displacement, but excluding the contents of the tanks.

WARNING

When loading the boat, never exceed the recommended maximum load. Always load the boat carefully and distribute the weight in a suitable manner in order to maintain the theoretical trim (approximately horizontal). Avoid placing heavy loads in the upper parts.



: CE marking indicating the compliance of the boat with all the provisions of the Directive. (See also: Written Declaration of Compliance).

Degrees of danger

DANGER	Indicates an extreme intrinsic risk that presents a high probability of death or permanent injury if proper precautions are not taken.
WARNING	Indicates a risk that presents a high probability of death or permanent injury if proper precautions are not taken.
CAUTION	Indicates a reminder about safety-related practices, or points out dangerous practices that could result in personal injury or damage to the boat or its components, or to the environment.

II. PRINCIPAL SPECIFICATIONS

	Model:	DUFOUR 430 Grand Large
	Constructor	Dufour Yachts 11, Rue Blaise Pascal 17180 Périgny - FRANCE
	Architecture:	Umberto FELCI
	Interior design	DUFOUR Design
	Yacht design category	A
	No. of the notified body	CE/0607
	CIN No.	FR-DUFHXXX1XXXX
	Primary means of propulsion	Sail
L _{max}	Length overall * (with bowsprit)	13.24 m
L _H	Hull length*	12.50 m
B _{max}	Maximum beam*	4.30 m
B _H	Hull beam*	4.30 m
H _A	Maximum air draft*	19.20 m
T _{max}	Unladen draft (Deep keel) *	2.10 m
	Deep keel weight	2600 kg
	Unladen draft (Shallow keel) *	1.75 m
	Shallow keel weight	2700 kg
	Standard mainsail area (approx.)	46 m ²
	Jib area (approx.)	29 m ²
	Genoa area (approx.)	38 m ²
	Maximum permissible on-board engine power	60 CV / 44 kW
	Water capacity excl. 40 L (approx.) water heater	430 L
	Diesel capacity (approx.)	250 L
	Holding tank / total volume	95 L
	Engine battery	105 Ah
	Auxiliary battery (excluding options)	315 Ah

* The above specifications comply with ISO 8866, i.e.:

L_{max}: maximum length of the boat including normally fixed parts such as bow rollers, pulpits, etc.

L_H: maximum length of the vessel including structural elements that are an integral part of the vessel, and excluding removable parts.

B_{max}: breadth of the vessel measured between the outermost portions and may include detachable parts such as top rails, railings, etc.

B_H: breadth of the vessel measured between the outermost fixed portions and excluding all removable parts

H_A: vertical distance between the unladen water line and the highest point of the mast structure. (this does not take into account equipment such as lights and antennas that may be attached to the masthead)

T_{max}: the maximum draft is measured at the lowest point of the boat's keel

N.B.: due to the trim and load of the boat, it is not usually possible to use all the various tank capacities for fresh water and diesel. It is recommended that you maintain a diesel reserve of 20%.

Weights and displacements

	A	B	C	D
M _{LC}	9982	10008	10082	10108
M _{MO}	10246	10272	10346	10372
m _L	2718	2718	2718	2718
M _{LDC}	12700	12726	12800	12826
m _{LA}	11702	11728	11802	11828

Values expressed in kg

A = deep keel + standard mast version - B = deep keel + furling mast version

C = shallow keel + standard mast version - D = shallow keel + furling mast version

M_{LC}: Boat's weight specification for light displacement

M_{MO}: Boat's weight specification for minimum conditions of use

m_L: maximum load used for the stability study, including the maximum recommended load (see builder's plate) and 95% of the total weight of the various liquids (drinkable or not) contained in the tanks.

M_{LDC}: Boat's weight specification for maximum load conditions

m_{LA}: Weight specification for the boat in maximum load conditions minus 85% of the stationary tanks or tanks holding fuel, oil and drinking water and minus 90% of the edible provisions, but including the combination of optional items of equipment or deck fittings least favourable for stability.

The total weight of liquids includes the black water tanks: the scenario taken into account is the most restrictive with three items of equipment.

Specific information

This vessel has been assessed with the help of the Stability Index (STIX), a measure of overall safety with regard to stability, which takes into account the effects of the length of the vessel, its displacement, hull proportions, stability characteristics and its resistance to flooding.

The second index (AVS, angle of vanishing stability) represents the heel angle at which stability is lost, in degrees.

	Minimum operating condition (M _{MO})	Loaded arrival condition (M _{LA})
STIX (deep keel)	41.61	37.99
AVS (deep keel)	120.0°	114.2 °

These values are those of the deep-keel version with a standard mast.

III. ELECTRICAL SYSTEMS

Safety and operating instructions for the electrical system

WARNING

Improper use of the DC and/or AC systems may give rise to fire or explosion hazards.
Improper use of the DC and/or AC systems may give rise to fire or explosion hazards.

Always:

- Check the condition of the batteries (charge and electrolyte level) and the charging system before putting to sea.
- Disconnect and remove batteries for wintering.
- Do not let battery voltage drop below 10.5 V during wintering.
- Carry spare bulbs for all navigation lights and interior lighting. Respect power ratings, particularly for navigation lights.
- Check the operation of navigational instruments.
- Check the operation of navigation lights before sailing at night.

Never:

- Work on an electrical installation under voltage.
- Modify an installation and the relevant layouts, except by a qualified naval electrician.
- Change or modify the circuit breaker capacity of protection devices.
- Install or replace the devices or electrical equipment by elements that exceed the prescribed capacity without recalibrating conductors and protection devices.
- Leave the boat unattended when the electrical installation is under voltage, except for an automatic bilge pump and protection circuits against fire or theft.

If a fuse or circuit-breaker trips repeatedly, you should consult a specialist to determine the cause of the short-circuit.

Fitting new equipment

Since 1 January 1996, electrical equipment is subject to the European Directive on "electromagnetic compatibility" (Ref 89/336/EEC). It is therefore necessary that any new equipment you may wish to install meets the requirements of this standard and bears the CE mark. Equipment must also be supplied with a compliance certificate and instructions for use.

In the case of 220 or 110 V installations, use only double-insulated or earthed equipment. Respect the instructions for installation when installing these devices (wire gauge, protection).

To avoid maintenance problems, note any modifications to the electrical layout in the manual.

Batteries

The standard battery installation consists of two 105 Ah auxiliary batteries and one 105 Ah engine battery. With the electric winch option, there are three 92 Ah AGM batteries. For a windlass and bow thruster, add one or two 92 Ah AGM batteries at the front.

Their capacities have been designed to handle the power requirements of the on-board accessories. To avoid any problems, it is necessary to keep a close eye on the maintenance and correct charging of the batteries.

CAUTION!

- When you install new electrical devices, make sure that the overall consumption of these devices remains proportional to the capacity of your batteries.
- Always disconnect the negative (-) battery terminal before the positive (+) terminal.
- Never allow a conductive object (tools, etc.) to bridge across the two battery terminals.
- When handling batteries, avoid any leakage of electrolyte liquid by keeping them horizontal. Wear gloves and proper clothing to avoid any risk of contact with the electrolyte in the event of a leak.
- In the event of a projection of electrolyte, thoroughly rinse the part of the body concerned and consult a doctor.

Electric windlass

CAUTION!

When you use the electric windlass, it is essential to run your engine with a slight acceleration.

DANGER!

The on-board 220V installation is protected by a circuit breaker and fitted with a residual current device. The wiring of additional 220V on-board accessories must be carried out by professionals and the master circuit-breaker updated if necessary.

- Do not modify the electrical installation of the boat or the relevant layout. Installation, modification and maintenance should be carried out by a qualified naval electrician. Have the system checked every 2 years
- Disconnect the boat power supply when the system is not in use.
- Connect the metallic housing of on-board electrical devices to the boat's protection conductor (green conductor or green with a yellow stripe).
- Use double-insulated or earthed electrical appliances.
- A test of the differential circuit breaker (RCD) should be carried out every month if possible.

CAUTION!

When the boat is moored at the quayside, set the isolator to the open position.

DANGER!

Your boat is not supplied with a shore/boat supply cable or a male plug for the shore outlet. The cable must be suitable for outdoor use. Its diameter should be adapted to its length and the power of the main circuit breaker (See the electrical diagram). The plug must be suitable for the shore socket (if necessary, seek professional advice). It should be as close as possible to the **IP 67/IEC529 type**

WARNING: To reduce the risk of electric shock and fire.

- Switch off the shore supply at the on-board isolator before connecting or disconnecting the shore/boat supply cable.
- Connect the shore/boat supply cable to the boat before connecting it to the shore outlet.
- Disconnect the shore/boat supply cable at the shore outlet before disconnecting it from the boat.
- Properly close the protection of the power supply inlet when docked

Never:

- Make any modifications to the shore supply cable: use only compatible connectors.
- Swim near a boat connected to a shore supply socket: risk of electrocution!

Location of the 220 V master circuit-breaker: aft starboard cabin.

Have the system checked at least every 2 years.

During haul-out maintenance, set to the closed position in order to have **earth [grounding] protection** via the shore socket.

WARNING

Never let the extremity of a ship/shore supply cable dangle into the water. It may create an electrical field that could injure or kill nearby swimmers.

IV. GAS INSTALLATION

General Information

- Pressure for use: 30 mbar (see indication on the label in the gas locker and on the regulator valve)
- Vents to use for the evacuation of burnt gas: hatch above the cooker and companionway
- Do not obstruct quick access to the elements of the gas installation (cylinder locker, shut-off valve).
- Regularly inspect the hoses at least once a year and change them if damaged, if the expiry date is exceeded, or five years after the manufacture date printed on the hose.
- Valves attached to empty cylinders must be closed and disconnected. Protective covers, caps and plugs must be kept in place. Reserve cylinders must be kept in housings or lockers for LPG cylinders with ventilation to the exterior, or stored at the exterior of the boat, protected from weather and mechanical damage, and in such a way that any leaking gas can only escape to the exterior of the boat.
- Lockers for LPG cylinders must not be used for the storage of any other equipment.
- Ensure that the gas cylinder and regulator comply with the requirements of the cooker (flow rate, pressure, type of gas) and with the regulations in force in the country where it is being used.
- Make sure that all valves are closed when replacing gas cylinders.

Operation of the LPG system

- The valves of the supply lines and cylinders must be closed when the devices are not used or before filling, and must be immediately shut off in case of emergency.
- The valves of the appliances must be closed before opening the cylinder valve.

WARNING

Fuel-burning naked-flame appliances use up the oxygen in the cabin and release combustion products inside the vessel. Proper ventilation is necessary: open both the deck hatch or porthole located nearby and the companionway when the appliances are in operation.

- The cooker is suspended and can therefore be used when under sail. However, limit its use when large angles of roll or heel are likely.

Checking the system

- The LPG system should be checked for leaks before each use as follows:
- Close the valve of the appliance, open the LPG cylinder valve, allow the pressure of the pressure gauge to stabilise, close the valve of the LPG cylinder, check the pressure indicated by the pressure gauge located near the cylinder for three minutes. The pressure indicated by the pressure gauge should be constant if there is no leak in the system.
- Information: the pressure gauge does not give an indication of the quantity of liquid LPG remaining in the cylinder but only its vapour pressure, which is a constant at a given temperature.

- If a leak of LPG is detected or suspected, immediately take the following steps:
- Cut off the supply at the main supply valve(s).
- Extinguish any naked flames and other sources of combustion (heating appliances, cooking appliances, lights, etc.)
- Do not operate any electrical switches.
- Evacuate the area, if possible.

WARNING

• Do not use an installation with a leak before it has been inspected and repaired by a competent person.

DANGER!

Never use a naked flame to look for leaks.

- N.B.: The tests above do not replace the recommended periodic inspection by a professional.

Safety warnings

WARNING

Never leave the boat unattended when naked flames are in use

Refrain from smoking or using a naked flame while LPG cylinders are being changed. Close the valve on the empty cylinder before disconnecting it to change. Properly ventilate the cylinder compartment when replacing cylinders.

Do not use the cooker/oven as a heating appliance.

If a leak is detected, close the main LPG supply and do not use LPG appliances.

After the boat has been shut up, never smoke when going below, and ensure that there is no smell of gas.

Do not modify the boat's LPG system. Installation, modification and maintenance must be carried out by a competent person. Have the system inspected at regular intervals or at intervals fixed by national requirements.

CAUTION!

Certain precautions must be taken to avoid any contact with naked flames or other hot areas.

Do not use solutions containing ammonia during manual tests for leaks

Detection system

The boat must be equipped with a fire alarm system (smoke detector, heat detector, etc.).

The recommended location is indicated on the evacuation plan (15).

This detector emits an audible signal in the case of an alert.

It has an independent battery that must be replaced when it indicates a loss of power, in compliance with the manufacturer's instructions or those indicated on the device.

It is essential to carry out a routine test at each boarding or every week in the case of prolonged presence on board.

If the test shows that the device is faulty, it should be replaced by an equivalent device.

V. DRAIN & SANITATION SYSTEM

Characteristics of the drain system (ISO 15083: 2003)

Pump type	Theoretical flow rate
Manual	38 L @ 45 strokes/minute
12 V electric	2,000 L/h

Read the operating and maintenance instructions for your boat's bilge pump carefully.

WARNING

The bilge pump system is not designed to handle water entering as a result of holing of the hull. It is intended to remove water coming from spray, leaks from seacocks or other moderate leaks.

CAUTION!

- The level of water in the bilges must be kept to a minimum
- Make sure that bilge pumps are in working order before putting to sea.
- Regularly clean the bilge and pump suction points or strainers to keep them free of any debris that could obstruct them.

If the watertight bulkheads isolating the forepeak and afterpeak are fitted with valves, these should be kept closed and only opened to drain water in the main bilge.

- Know where to find each hand pump and its handle.
- Locate the switch for the electric bilge pump on the electrical panel.

Pressurized fresh-water pump

Fresh water is supplied to the sink and washbasins by an electric pump. A filter is installed upstream of the pump, and must be cleaned regularly.

Never allow the pump to run if the tank is empty. Refill the tank before using the water supply again.

The tanks can be sterilized using Clonazone® tablets (available from pharmacies). Every year, remove the inspection covers and clean them by filling with water containing a bactericidal detergent; leave it to act for a few hours, then rinse two or three times. During wintering, completely fill the tanks to avoid the development of algae or bacteria. If there is a risk of freezing, empty the tanks; never use anti-freeze.

Hot water is produced by a water-heater connected to the engine cooling circuit and the shore electric supply.

After the water-heater has been emptied, make sure that the element is covered before power is re-applied.

Seacocks

Seacocks are of the ¼-turn type:

- OPEN position: handle in the direction of the seacock body,
- CLOSED position: handle perpendicular to the seacock body.

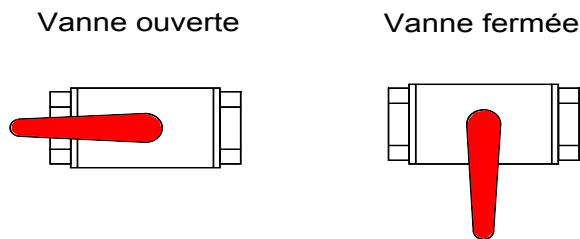

CAUTION!

- Never interfere with the tightening of the seacocks to the hull. In the event of a leak, consult a professional.
- In bad weather or when leaving your boat, close all the sanitation system seacocks.
- Keep the seacocks closed when not in use and remember to manipulate them regularly to maintain their flexibility of use. An unused seacock can eventually seize up.
- During wintering, clean and rinse the seacocks and skin fittings. Inspect brass fittings; slight surface corrosion is normal.
- In the event of more serious corrosion, consult your agent.

Operation of the sea toilets

- Open the sea water inlet cock.
 - Open the bowl emptying seacock.
 - Set the lever to the "FLUSH" position.
 - Operate the pump.
 - To empty the bowl and avoid any water slopping when heeling, set the lever to the "DRY BOWL" position.
 - Operate the pump until the bowl is dry.
 - Repeat these flushing/emptying operations as many times as is necessary to ensure complete emptying of the pipes.
- When toilets are not being used, set the lever to the "DRY BOWL" position, or the "CLEF" position for certain models.
- **Close seacocks after use, as the toilet is below the waterline.**
 - Change the toilet seals regularly.

Holding tank operation (ISO 8099:2000)

CAUTION!

Where a holding tank is fitted, take care to lock the discharge valve, to avoid any accidental discharge during wintering.

- Black water tanks operate with the manual toilet pump.
 - The contents of the toilet pan are discharged straight into the holding tank.
 - Periodically check that the vent is working properly.
 - A deck plate is provided for emptying the tank.
 - The discharge valve can be sealed in the closed position using a padlock.
 - Once a season, arrange to clean out the tank using a biodegradable disinfectant chemical. Use a biodegradable deodorant product without formaldehyde to limit odours.
- Leave the system empty if the vessel is to be left in below-freezing temperatures. During winter lay-up, use a food-grade, non-toxic antifreeze that complies with local regulations.

VI. FLOODING

To avoid the risk of flooding the boat:

- Check that portholes, deck hatches, and any other openings that may cause flooding, are closed before putting to sea.
- While under way, close all seacocks when they are not in use, except for the engine water intake.
 - Do not exceed the maximum recommended loading.
 - The level of water in the bilges must be kept to a minimum.
 - Avoid adding weight in high places so as not to affect the stability.

Periodically check:

- Skin fittings, seacocks and pipes are watertight.
- Proper emptying of the cockpit drains.
- Stern glands or sail-drive seals for watertightness.

WARNING

Cockpit locker covers must be fastened shut before putting to sea. This is particularly important for lockers with a serious risk of flooding

VII. FIRE PROTECTION

Installation

Since fire extinguishers are subject to national regulations, they are not supplied with the boat. However, when in use, this boat must be fitted with portable extinguishers with the following capacities, installed in the following locations (see drawing in appendix):

- No. 1 - cockpit locker, within reach of the helmsman - capacity 1 kg - 5A34B
- No. 2 - saloon banquette (fore) - extinction capacity 1 kg - 5A34B

If you decide to install a carbon dioxide (CO₂) extinguisher, be aware that it may only be fitted in accommodation areas that contain powered electrical equipment (e.g. electric motors, battery compartments, electrical panels) or flammable liquids (e.g. galley).

Only compatible replacement parts must be used in the fire protection system. They must bear the same markings and be technically equivalent.

In addition, a fire blanket must be stowed in the aft starboard cabin (in the L-galley version) or near the cooker, which can be very useful in the case of a cooker fire caused by oil.

Similarly, for safety on deck, a fire bucket equipped with a lanyard must be stored in an immediately accessible locker.

If non-combustible materials are stored in the engine compartment, they must be secured to avoid the risk of falling onto the machinery and must not obstruct access to the engine compartment or its exit.

WARNING

If a CO₂ extinguisher is fitted, the following information must be displayed close to its location:

“This extinguisher contains CO₂ - use only on electrical or cooker fires. To avoid suffocation after discharging, leave the area immediately. Ventilate before entering.”

Do not open the engine compartment immediately after putting out a fire to avoid the release of toxic smoke or spraying of burning materials (oil, water)."

Safety Instructions

CAUTION!

It is the responsibility of the owner/skipper to:

- Have fire-fighting equipment checked in accordance with the stipulations of the builder and the regulations in your country.
- Replace fire-fighting equipment if it has expired or been discharged, with extinguishers of equal or greater capacity.
- Show members of the crew:
 - The location and operation of fire-fighting equipment.
 - the location of the engine compartment discharge hole
- Ensure that fire-fighting equipment is readily accessible whenever the boat is occupied.
- Always keep the bilge clean and check that there is no fuel or gas vapour and no fuel leak.
- Indicate escape routes.

You must never:

- Obstruct passageways to the emergency exits (deck hatches).
- Obstruct safety controls (gas valves, fuel valves, electrical switches).
- Obstruct fire extinguisher stowages.
- Leave the boat unattended with a cooker or heater on.
- Use a gas lamp in the boat.
- Fill a fuel tank or change a gas cylinder while the engine is running, or the cooker or heater are on.
- Smoke while handling fuel or gas.
- Place free-hanging curtains near the cooker or any other appliance which has an open flame.
- Store flammable substances in the engine compartment.
- Modify, or allow any non-qualified person to modify, any of the boat's installations (especially electrical, fuel, or gas).

VIII. ENGINE

Regular maintenance must be carried out in compliance with the engine manufacturer's recommendations. Read the engine operating instructions that come with the boat carefully. Do not hesitate to consult your agent or a qualified professional. In particular, follow the instructions for wintering.

General precautions

CAUTION!

Do not use the sail and engine if the heel angle is more than 10°.

Any engine change must respect the capacities of the boat and be performed by an engineer specializing in marine mechanics.

After the first launching and tensioning of rigging, check the alignment of the propeller shaft or the sail-drive flange ring.

- Ensure that the ventilation openings (vents, engine air intake grating) are clear.
- Make sure that the water intake seacock for the cooling system is open, and that water is indeed coming out of the engine exhaust.
- Prevent any deterioration to the fuel supply circuits.
- Do not store equipment containing petrol (outboard motor, tank, petrol generator, etc.) in compartments not designed for this purpose.

Put the throttle in neutral before starting the engine to keep the boat from moving and/or the propeller from turning.

On subsequent launches, a brief check of propeller fixing can be made. Incorrect operation of the folding propeller will lead to vibration.

Regularly check the condition of the anodes and ensure that they are suitable for the boat's environment (fresh water, salt water). Change the anodes every year. The anodes have an average life of 1–2 years.

These anodes are made of zinc. You must not use magnesium ones. Impressed current cathodic protection systems should be avoided.

If the anodes are not eroded, you need to check:

- that they have not been painted over,
- that they are correctly attached and in contact with the hull,
- and that they are indeed made of zinc.

Exhaust gas emission

DANGER!

Internal combustion engines produce carbon monoxide. Prolonged exposure to exhaust gases can have serious consequences, and may even cause death.

Safety

DANGER!

In order to avoid all risk of serious injury from the propeller, the engine must not be started when there are people swimming near the boat.

Whenever possible, the engine must be stopped for any engine maintenance or checking operations. Otherwise, special attention must be paid to moving parts (propeller shafts, belts, etc.) in order to avoid any risk of injury.

Wintering

Read the operating and maintenance instructions for the engine that goes with your boat and the instructions for wintering carefully.

In the absence of other instructions, proceed as follows:

- Close the engine water intake seacock,
- Disconnect the hose from the engine water intake seacock,
- Drain the sea-water circuit,
- Place the pipe into a drum of -25° anti-freeze coolant,
- Run the engine until the fluid comes out of the exhaust,
- At the end of this operation, re-connect the pipe to the seacock,
- Attach a notice to the electrical panel and the battery isolator stating that the engine water intake seacock is closed.

IX. FUEL INSTALLATION

In the event of deterioration, flexible fuel pipes must be replaced by pipes bearing the same markings. Do the same for all fuel lines.

CAUTION!

- Depending on the trim and loading of your boat, not all of the nominal fuel capacity may be used. Always maintain a 20% reserve for safety.
- Avoid contact between flammable materials and hot parts of the engine.
- Clean up any overflow of fuel that may occur when filling the tanks.

You must never:

- Store flammable materials in unventilated spaces.
- Smoke while filling tanks.
- Obstruct ventilation openings (vents, engine air intake grating): make sure they are clear.
- Modify the installation except by a qualified technician.

X. HELM SYSTEM

The steering system plays a vital role in the safety and comfort of your boat.

Helm

The DUF0UR 430 is fitted with a dual wheel with a system of rudder cables and chains as well as with an emergency tiller.

Checks to be carried out periodically: check the play in the various elements (rudder stock/bearings, tension and wear in mechanical components) and grease the sprocket and chain if necessary.

Your system is designed with 6mm stainless steel cable, twisted 7x19. These cables may be replaced due to wear and fatigue.

The frequency of the change depends on the type of use and the tension and maintenance conditions that might affect their lifespan.

Careful examination will reveal any damaged cables. A cloth soaked in machine oil may be used to wipe along the entire length of the cables.

If you find a broken twist, this means that the cable has reached the end of its lifespan and that you will need to change it.

The same type of cable (material and diameter) must strictly be used to avoid any risk of breakage or premature fatigue.

In the event of any doubt or problem, consult your agent.

Emergency tiller

CAUTION!

- The **Dufour 430** is fitted with an emergency tiller which must be kept readily accessible; we advise stowing it in one of the nacelle cockpit lockers.
- It is designed only for sailing at reduced speed in the event of damage to the helm.

To use it:

- Unscrew the deck-plate to reveal the head of the rudder stock.
- Fit the tiller onto the head of the rudder stock.

XI. SAILING

WARNING

In all situations, adapt the speed of your boat to the surrounding conditions and always maintain a safety margin. Pay particular attention to:

- Sea conditions, currents and the strength of the wind
- Movement of other boats
- Port manoeuvres
- When passing through mooring areas
- Obey the rules of right of way as set out in the COLREGs
- Make sure that you always have sufficient distance to stop or manoeuvre if necessary to avoid a collision
- Respect speed limits
- Out of courtesy and for the safety of other vessels, make sure not to create a significant wake near other craft.
- Movable items must be carefully secured when at sea

WARNING

- You must fit your boat with grab lines. Anchor-points are provided on the deck. Please refer to the deck fittings plan for your boat. These grab lines are used as an anchor-point for the harnesses for moving towards the front of the boat.
- The stability of your boat has been designed taking into account the boat's weight specification for light displacement, the standard equipment on board and the manufacturer's catalogue options.

Any alteration to on-board weight distribution (e.g., the addition of a radar, engine replacement, etc.) can affect the stability, trim and performance of your boat.

Breaking waves represent a significant threat to stability.

Towing another boat produces significant extra loading, which will have an adverse effect on the stability of your boat.

- **You must never:**

Lift heavy weights using the boom.

Field of vision

The skipper's vision from the steering position may be obstructed by one or more of the following variable conditions:

- Loading and distribution of the load
- Speed
- Sea conditions
- Reduced visibility (due to rain, darkness and fog)
- Reduced visibility (due to changing and raising the sails)
- Lights inside the boat
- Position of awnings or covers
- Moving people or equipment located within the helmsman's field of vision.

Pay attention when you are moving from one helm position to another.

CAUTION!

Some large size forward sails (Genoa, code 0, spinnakers, etc.) may obstruct vision for a long time. Keep an active watch while they are in use.

XII. FALL PREVENTION AND MEANS OF GETTING BACK ABOARD

While underway, it is recommended to move about on deck only in areas provided for this purpose. These areas (side decks, cockpit, coach roof, lateral seats, etc.) are provided with non-skid coverings or teak (optional) to make it safe to move about.

On the DUFOUR 430, the entire working deck inside the guard lines and bulwarks can be used safely. Passageways have been provided, when necessary, on glass surfaces and are marked by anti-slip zones.

Note that the aft platform, when open, is not considered as a secure area. Moreover, it must be kept closed when sailing.

Depending on sea conditions, wind and the degree of heel, it is also recommended that you use the harness by attaching it to the various attachment points mentioned in the deck fittings plan.

When sailing, use whenever possible the various handholds provided by the helm grab rails, cockpit table, lateral grab rails on the coach roof, shrouds, etc.

The DUFOUR 430 is equipped with a telescoping emergency ladder fixed to the aft gate. To use it, lower the aft gate by releasing the hoisting line and then unfold the ladder and pivot it into the correct position.

A safety ladder is also provided in case of emergency. When the boat is in use, it must be located on the port or starboard pushpit and must be accessible from the water. Be sure to familiarize yourself with this system, so that it is operational in any circumstances, including when under sail.

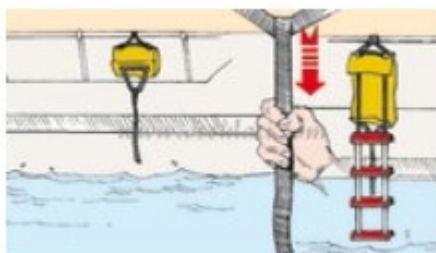

XIII. LIGHTNING PROTECTION

Your boat is protected against lightning. The rigging is electrically earthed (grounded). Nonetheless, for your safety, it is necessary to respect certain precautions.

Maintenance

If the vessel is struck by lightning:

- the protection equipment must be inspected for material damage and the condition of the system, including the continuity of the earthing, must be checked.

- compasses, electrical and electronic equipment must be inspected to determine if damage or compass calibration changes have occurred.

Personal protection during thunderstorms

WARNING

During a thunderstorm, it is recommended that you comply with the following instructions:

- People should stay below as much as possible.
- People should stay out of the water and not let their arms or legs hang into the water.
- While ensuring the satisfactory control of the boat and navigation, passengers must not touch any element connected to a lightning protection installation, especially not in such a way as to create a bridge between these elements.
- People should avoid touching any metallic parts of the rigging, spars, deck fittings and guard-lines.

XIV. ENVIRONMENTAL PROTECTION & SAFETY

We recommend that you find out about local regulations concerning the environment and obey international regulations against pollution in the marine environment (MARPOL), together with the codes of good practice.

Do not discharge the toilets or the contents of the holding tanks near coasts or in prohibited areas; use port or marina pumping systems for emptying the holding tanks before leaving port.

CAUTION!

- Most cleaning products, engine oils and fuels are likely to impact the environment, so they should be discharged in authorized locations (check with the Harbour Master's office).
- Do not run the bilge pump when oil or fuel is present in the engine compartment, as these chemicals must be discharged in authorized locations.
- Certain products can also pose a risk to your safety and that of others, which is why it is important to read and follow the instructions for use.
- Chemicals must be labelled and stored in an appropriate place on the boat.

XV. SAFETY FACILITIES

There is no harmonization of mandatory safety equipment across the European Community. You should find out about current national requirements for CE-marked vessels.

In France, the skipper is responsible for ensuring that recreational craft bearing the CE mark carry the mandatory handling and safety equipment stipulated for the relevant sailing category.

Your boat is equipped with a life raft locker in the transom – direct access after opening the aft gate. Carefully read the life raft instructions manual. The entire crew must be familiar with the use of all safety equipment (harnesses, flares, life raft, etc.). Sailing schools and clubs regularly organise training sessions.

XVI. HANDLING, TRANSPORTING, HAUL-OUT

When craning, take care that the slings are correctly positioned and are not fouling the propeller, the sail-drive or a fragile transducer.

Lifting frames must be wide enough, or fitted with spreaders, so as to avoid applying excessive lateral pressure on the rubbing strakes.

Avoid allowing slings to foul the life-lines. During transport or haul-out, the keel should be in proper contact with its support and should be taking most of the boat's weight.

Cradle pads must be positioned against structural elements in order to exert only the pressure necessary for the boat to be properly balanced.

Take advantage of haul-outs to inspect the propeller, rudder, skin fittings and sensors.

CAUTION!

The aft lifting point is located near the propeller.

XVII. MOORING, ANCHORING, AND TOWING

Be sure to regularly inspect the various anchoring points of the boat. Replace any that show signs of deterioration.

CAUTION! (ISO 15084:2003)

- The anchor points for anchoring and/or towing are the 2 fore cleats, which have a breaking strain of approximately 6000 kg. Rear and mid-ship cleats can also be used for mooring. They have a breaking strain of approximately 6000 kg.
- The breaking strain of the lines/chains should in general not exceed 80% of the breaking strain of the anchor points, i.e. in this case a galvanized chain of 10 mm max. and a polypropylene line of 18 mm max.
- Always tow or be towed at reduced speed. Never exceed the hull speed of a displacement boat in tow.
- The tow line should always be made fast in such a way that it can be released when under load.

Responsibility

It is the owner/operator's responsibility to ensure that the mooring lines, towing cables, anchor chains and lines, together with the anchors, are suitable for the boat's intended use, i.e. that the lines or chains do not exceed 80% of the breaking strain of the corresponding anchor point.

Moreover, the owner must take into consideration all necessary actions when attaching a tow line to the boat.

XVIII. GUARANTEE, TRANSFER OF OWNERSHIP

A) CONTRACTUAL GUARANTEES

Note: This guarantee does not apply to boats being used for commercial purposes (it being specified that any hiring or chartering activity falls into this category) nor to sailing boats taking part in competitions, which may be covered by special guarantees.

8 - Guarantees

a) New boats and equipment:

8.1.1 – For both Commercial Purchasers and private consumers domiciled outside the territory of the European Union, the Seller grants the statutory warranties as defined in the context of the sale of vessels by Articles 1641 and 1648 of the French Civil Code and in the context of a marine construction contract by Articles 7 and 8 of Law no. 67.5 dated 3rd January 1967 pertaining to vessels.

8.1.2 – For Purchasers domiciled within the territory of the European Union and taking out the contract as private consumers, the Seller is required to furnish the guarantees as defined in the context of a boat sales contract by Articles 7 and 8 of the Act dated 07/01/1967 pertaining to vessels, and in the context of the Order (2005-136) dated 17/02/2005 and incorporated into the French Consumer Code. Independently of this guarantee, the Seller remains liable for discrepancies between the goods and the contract and for redhibitory defects under the conditions provided for under Articles 1641 to 1649 of the French Civil Code (see. 8.1.1).

8.2 – Visible defects: acceptance by the Purchaser releases the Seller from their obligation in respect of discrepancies and visible defects.

8.3 - Contractual guarantee:

Except for guarantee or penalty clauses expressly agreed at the time of accepting the order, the Seller's guarantee is granted under the following conditions:

- The Purchaser benefits from a contractual guarantee running for two years from the date of acceptance of the vessel, as noted on the acceptance report.
- This is limited to the replacement or free repair, at the yacht-builder's discretion, of any parts acknowledged as being defective by the yacht-builder's technical services; this being without any other compensation of any kind.
- For components and accessories visibly bearing the mark of another supplier, the guarantee is limited to

the guarantee offered by that supplier.

- It is stipulated that any handling, transport, parking, or conveying costs incurred in carrying out these operations remain the sole liability of the buyer/user, unless DUFOR YACHTS yacht-builders offer to waive them in full or in part.
- The boat-builder's warranty excludes:
 - the cost of transporting the boat or any parts, and any consequences thereof, together with expenses and/or any damage arising out of the inability to use the boat and/or the equipment;
 - normal wear and tear;
 - cracking, crazing, or discolouration of the gelcoat;
 - damage resulting from:
 - fortuitous events or cases of force majeure;
 - conversions and modifications, or repairs, even partial, carried out other than in workshops authorized by the maker;
 - failure to observe the maintenance recommendations set out in the Owner's Manual supplied with the boat;
 - improper use, in particular through negligence, carelessness, abuse, or abnormal usage;
 - participating in competitions;
 - failure to take necessary protective measures;
 - unsuitable storage or transport conditions.

In order to benefit from the yacht-builder's contractual guarantee, each time they make a claim under it, the buyer/user will be required to submit the boat delivery certificate and the guarantee document, duly completed, and, on pain of rendering it void, must notify their dealer/vendor of the fault or defect in writing, in detail and with justifications, within 15 days of its being discovered.

8.4 – the guarantee covers usage at sea in wind and sea conditions acceptable for safety and in accordance with the vessel's approval category. Under these conditions, it cannot under any circumstances cover events arising during or resulting from collisions, groundings, breaking seas, tidal waves, cyclones, severe storms, and all other exceptional events and/or events arising out of an error of seamanship.

8.5 – Loss of or damage to products occurring after handover do not release the Purchaser from their obligation to pay the price.

b) Second-hand boats and equipment:

The order form specifies if the boat or equipment is second-hand. The Purchaser benefits from a contractual guarantee, covering hull and engine only, running for one year from the date of acceptance of the vessel or goods, as noted on the acceptance report.

c) In addition to the contractual guarantee detailed above, the Seller remains liable for discrepancies in the goods and for latent defects under the conditions provided for under Articles 1641 to 1649 of the French Civil Code and the provisions of the Order dated 17/02/2005, where applicable.

B) COMMON GUARANTEE CONDITIONS

Any claim under these guarantee conditions must be made formally to DUFOUR YACHTS in writing as soon as the defect is discovered, and within eight (8) days for claims under the contractual guarantee. Any claim will also be required to quote the serial number of the boat concerned, and where applicable the part number(s) of the part(s) involved in the guarantee claim.

Furthermore, the request must indicate the exact circumstances under which the problem occurred.

In order to investigate the request, DUFOUR YACHTS may ask for any details and appoint, at its own expense, a surveyor or technician of its choice to determine the circumstances of the occurrence of the problem and demand any necessary papers.

Immobilization following problems encountered and/or replacement and/or repair work, whatever the duration, does not create entitlement to compensation.

The owner shall under all circumstances remain liable for parking fees, customs dues and other ancillary expenses.

All repairs and/or replacements will be carried out by an authorized DUFOUR YACHTS agent or by a professional duly acting under the Boatbuilder's instructions. If the nature of the repairs requires the guarantee repair work to be carried out in DUFOUR YACHTS workshops or in any location other than the place where the Product is located, the owner will be liable for the cost of both outward and return transport to the Yacht builder.

In the event that the boat needs to be taken out of the water, haul-out and re-launching costs will be at the owner's expense.

C) TRANSFER OF GUARANTEES

The guarantees are afforded to the first purchaser of the boat involved. They are only transferable with DUFOUR YACHTS' prior written agreement.

An ownership transfer note is supplied with the Product documents. This must be sent to DUFOUR YACHTS within thirty (30) days of the transfer.

This note must bear the names, addresses and telephone numbers of the old owner and the Purchaser, the date of sale, and the Product's hull number.

Upon reception, DUFOUR YACHTS will confirm the guarantee expiry dates and specify whether the unit has received the annual inspection that gives entitlement to the continuation of the contractual guarantees.

D) STATUTORY DECLARATIONS

Article L.211-4 of the Consumer Code:

"The seller is obliged to deliver goods that are compliant with the contract and is liable for any defects of compliance on delivery.

He shall likewise be liable for discrepancies arising out of the packaging, assembly instructions, or installation when he is liable for this under the contract or it has been carried out under his responsibility."

Article L. 211-5 of the Consumer Code:

"In order to conform to the contract, the goods must:

1) Be suitable for the normal expected use for similar types of goods and, where applicable:

- correspond to the description given by the seller and possess the qualities the latter has presented to the buyer in the form of a sample or model;

- present the qualities that a buyer may reasonably expect with regard to public declarations made by the seller, by the producer or by his representative, particularly in advertising material or labelling;

2) Either present the characteristics defined by joint agreement between the parties, or be suitable for any special usage sought by the buyer that the seller has been made aware of and has agreed to."

Article L.211-12 of the Consumer Code:

"Actions arising out of a discrepancy lapse after two years from the date the goods are handed over."

Article 1641 of the Civil Code:

"The seller is obliged to guarantee against latent defects in the article sold which render it unfit for its intended use, or which adversely affect this use to such an extent that the buyer would not have purchased it, or would have only paid a lower price, if he had known about them."

Article 1648, paragraph 1 of the Civil Code:

"Actions arising out of redhibitory defects must be brought by the purchaser within two years of discovery of the defect."

This page intentionally left blank.

This page intentionally left blank.

This page intentionally left blank.

LAYOUT DIAGRAMS

1. Presentation	34	
2. Accommodation layout	35	
3. Deck fittings layout	38	
4. Sail plan	40	
5. Running rigging, sheets and halyards layout		42
6. 220V circuit diagram	47	
7. Charging and power system diagram	49	
8. 12V electric panel		51
9. Electrical panel rear wiring	53	
10. 12V electrical installation diagram	57	
11. 220V electrical installation diagram	60	
12. Fuse diagram	63	
13. Rudder system diagram		66
14. Gas system diagram	68	
15. Abandon ship plan	71	
16. Freshwater system diagram	74	
17. Drainage system diagram	77	
18. Skin fitting location diagram	79	
19. Mechanical installation diagram		82
20. Diesel system diagram	84	
21. Holding tank installation diagram	86	
22. Lifting diagram	88	
23. Navigation lights		90

24. Presentation



01

25. Accommodation layout

<i>Label</i>	<i>Description</i>
A	3-cabin front galley version
B	4-cabin long galley version

A

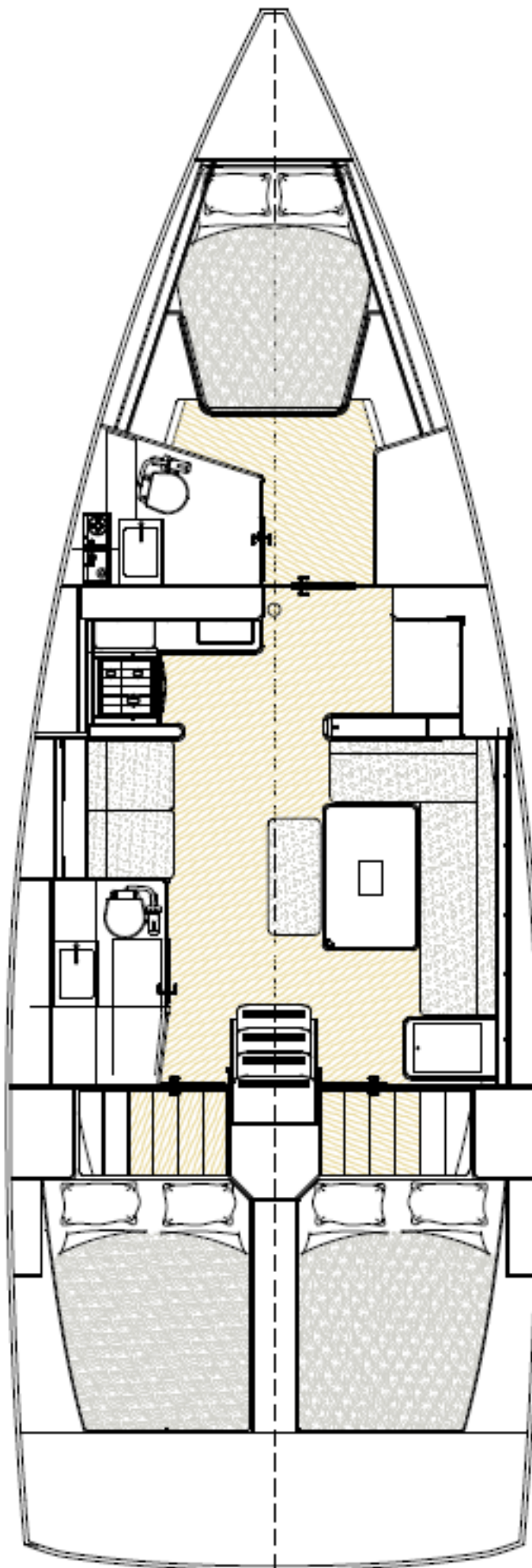

02

B

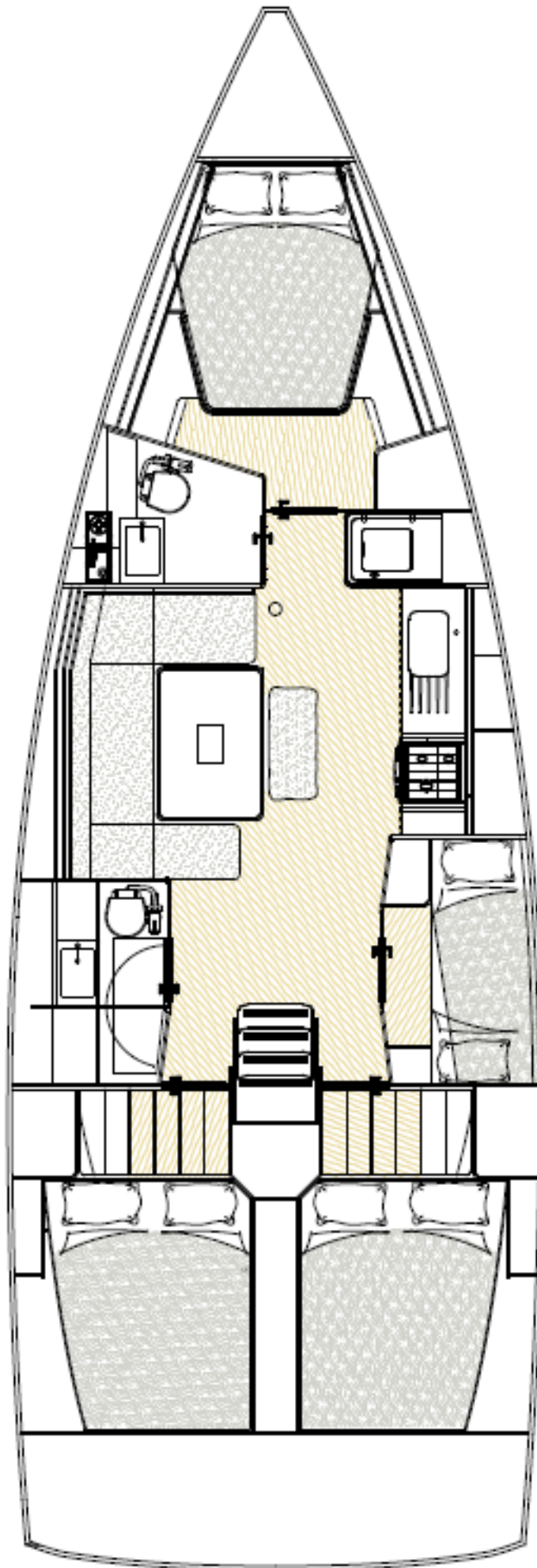

02

26. Deck fittings layout

No.	description	remarks
A	JACKLINE ANCHOR POINTS	Port and starboard cleats
B	TOWING POINTS	PT/STBD
C	IT IS OBLIGATORY TO KEEP THE HATCHES CLOSED WHEN SAILING	
D	"MAN OVERBOARD" REBOARDING LADDER	
E	LIFE RAFT STOWAGE	
F	ANCHOR POINT FOR SAFETY HARNESS	
G	LOCKER MUST BE CLOSED WHEN UNDERWAY	
1	BOW ROLLER	
2	WATERPROOF PAD EYE D8	Mast foot
3	FOLDING PAD EYE D8	Furling line
4	WATERPROOF PAD EYE D10	Spinnaker option
5	WATERPROOF PAD EYE D10	
6	FOLDING PAD EYE D8	Releasable forestay option
7	FOLDING PAD EYE D8	
8	SINGLE CLUTCH	furling line
9	SINGLE CLUTCH	spinnaker option
10	TRIPLE CLUTCH	
11	5-SHEAVE DECK ORGANIZER	
12	SIMPLE PULPIT	
13	PORT PUSHFIT	
14	STARBOARD PUSHFIT	
15	SWIMMING LADDER	
16	COACH ROOF GRAB RAIL	
17	FUEL DECK PLATE	
18	SELF-TACKING JIB TRACK	
19	GENOA TRACK	option
20	ALUMINUM MOORING CLEAT	
21	WINCH T45	

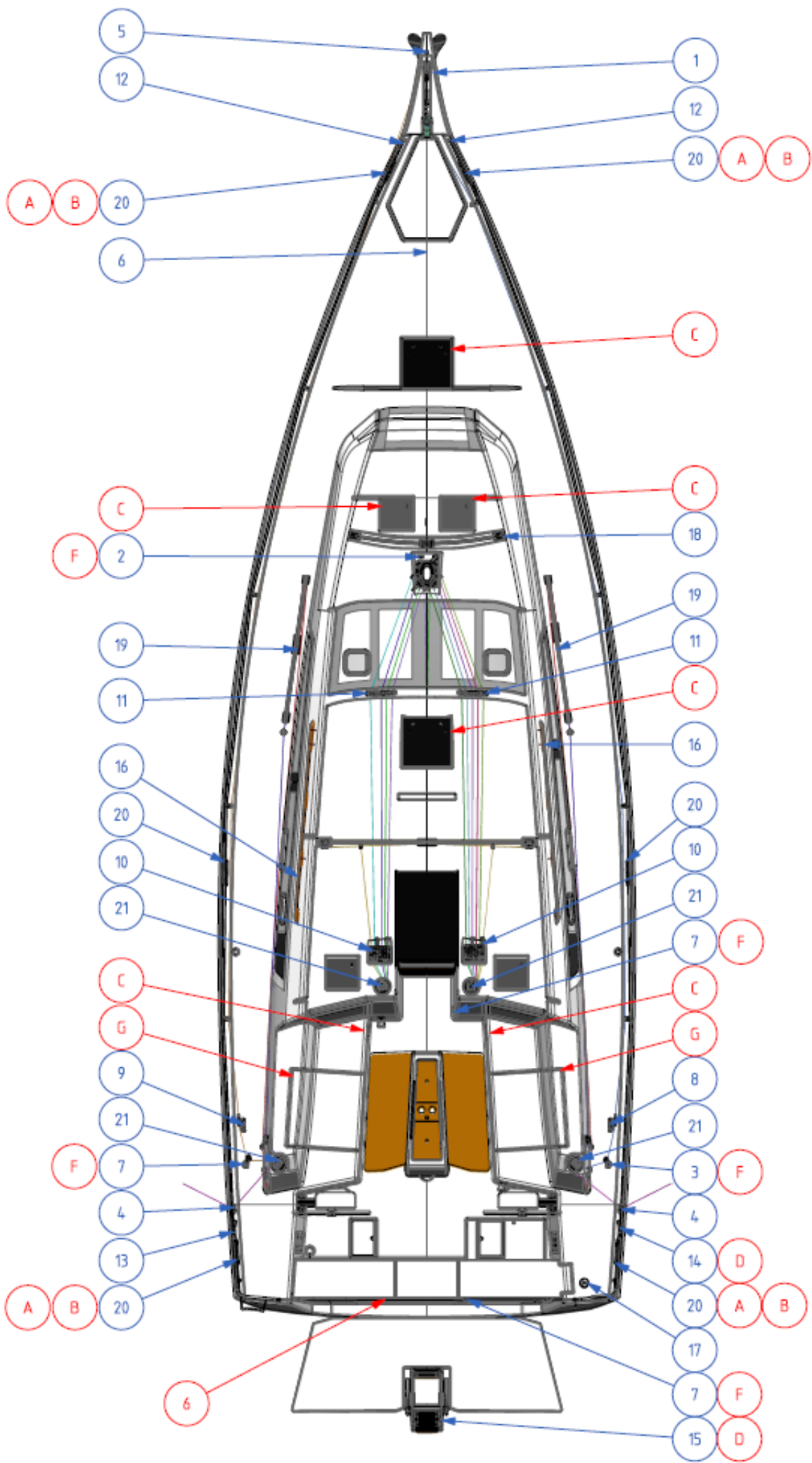

27. Sail plan

I	16.53 m
J	4.52 m
P	16.04 m
E	5.30 m
Self-tacking jib LP	3.92 m
Mainsail area	46 m ²
Self-tacking jib area	29 m ²
Genoa area*	38 m ²
* Option	

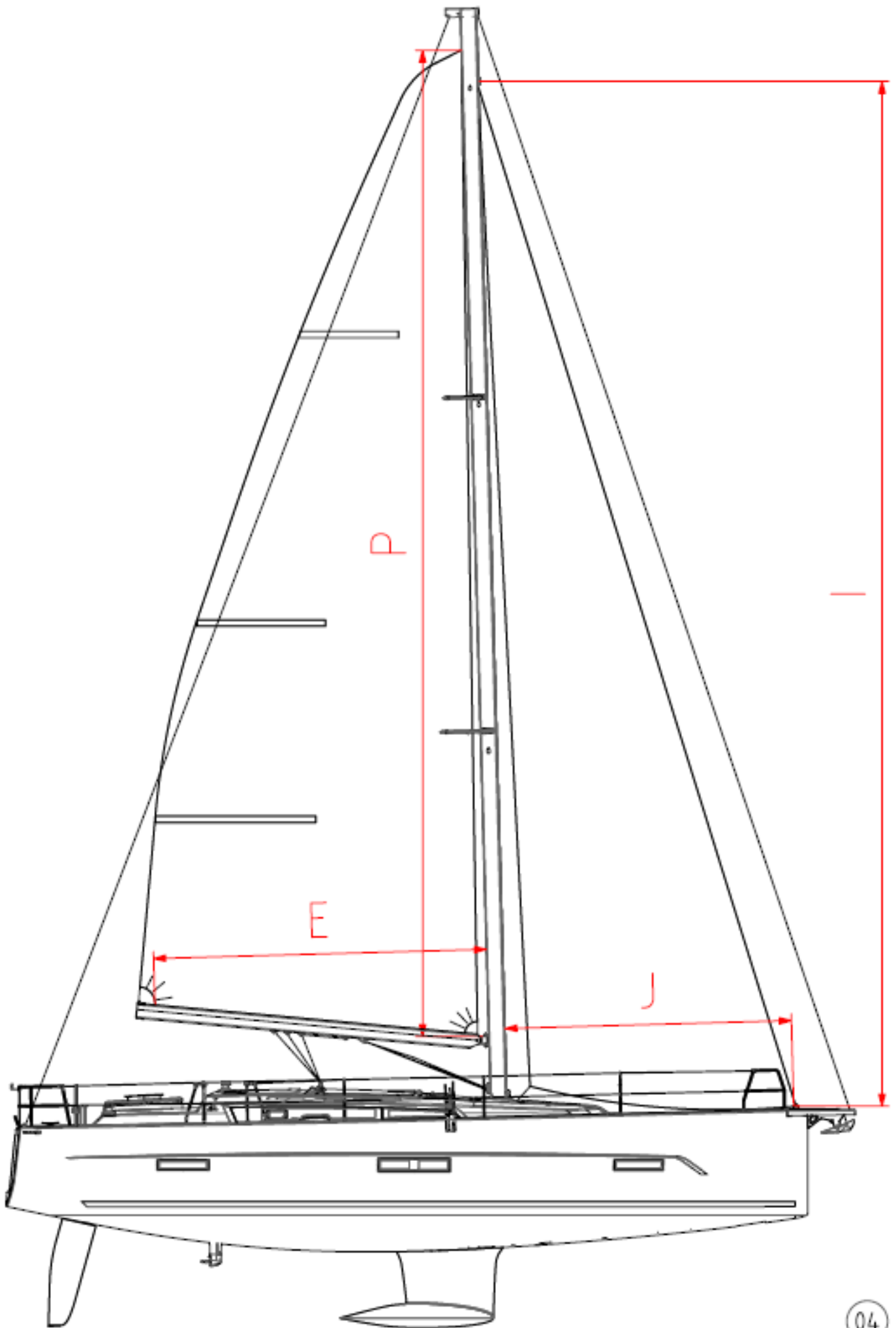

04

28. Running rigging, sheets and halyards layout

<i>Label</i>	<i>Description standard mast</i>
1	Mainsail traveller sheet*
2	Self-tacking jib sheet
3	Releasable forestay*
4	Self-tacking jib / Genoa halyard
5	Reef 1
6	Rigid boom vang
7a	Standard mainsheet
7b	German System mainsheet*
8	Reef 2
9	Mainsail foot
10	Mainsail halyard
11	Code 0/Spinnaker halyard
12	Genoa sheet*
13	Genoa traveller sheet*
14	Code 0 sheet*
15	Code 0 tack*
16	Furling line
17	Backstay hoist*
*	Option
A	D80 MAST FOOT BLOCK
B	D72 SYNC BLOCK
C	D90 FIDDLE BLOCK
D	D72 BECKET BLOCK
E	D90 SYNC BLOCK
F	D60 SYNC BLOCK
G	D50 SYNC BLOCK
H	D40 SINGLE BLOCK
I	D60 BECKET - CLEAT BLOCK

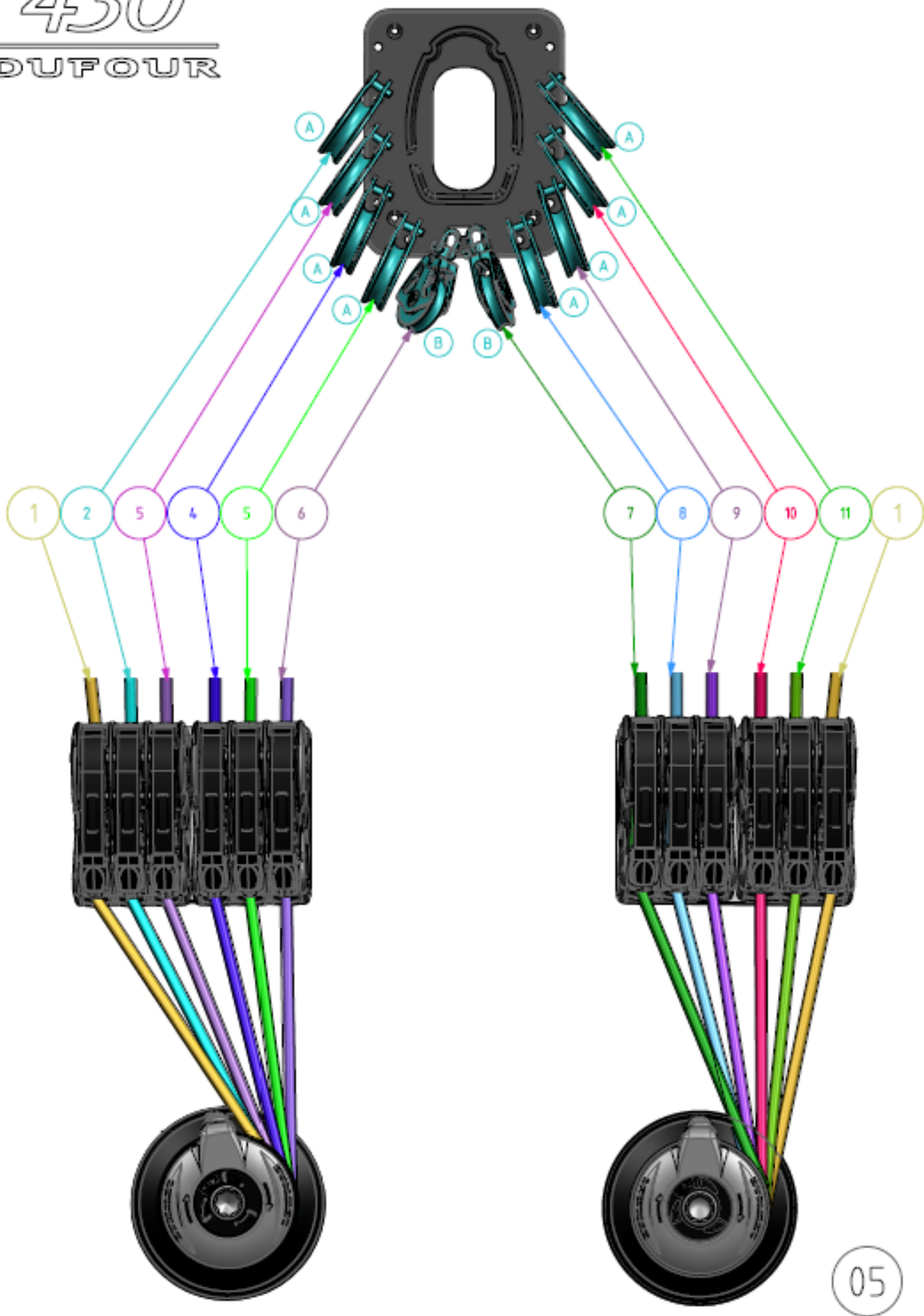

05

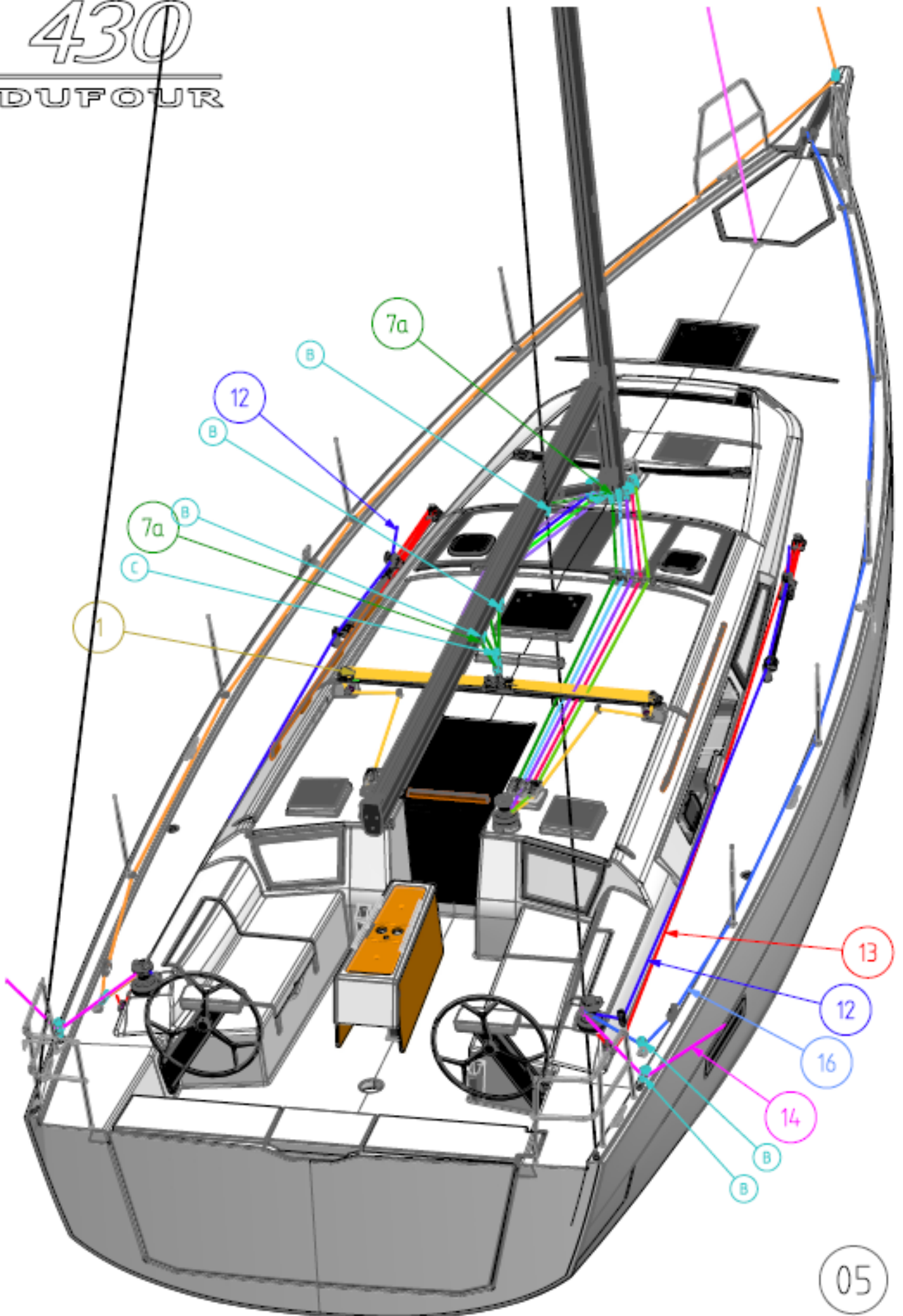

430

DUFOUR

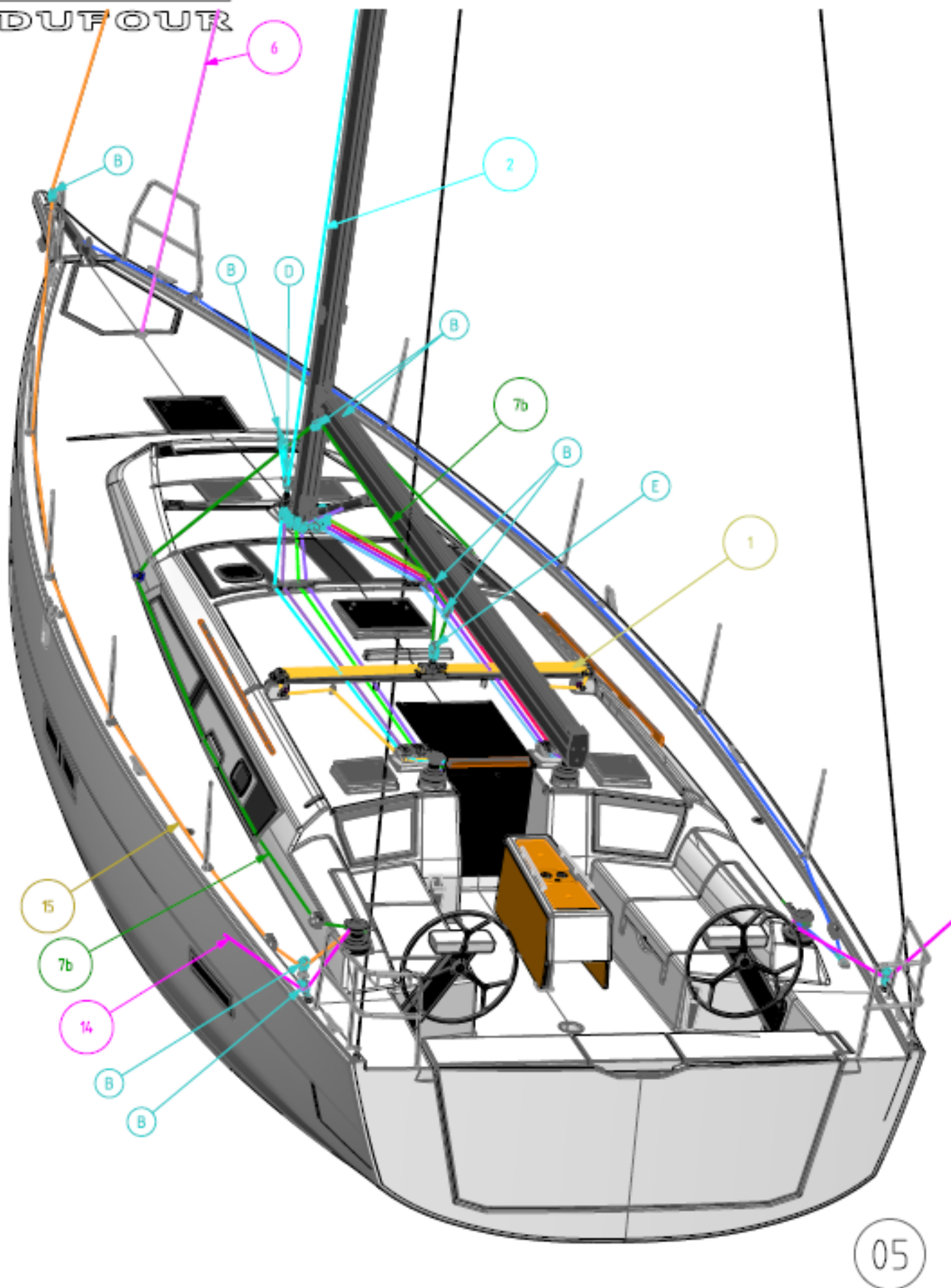

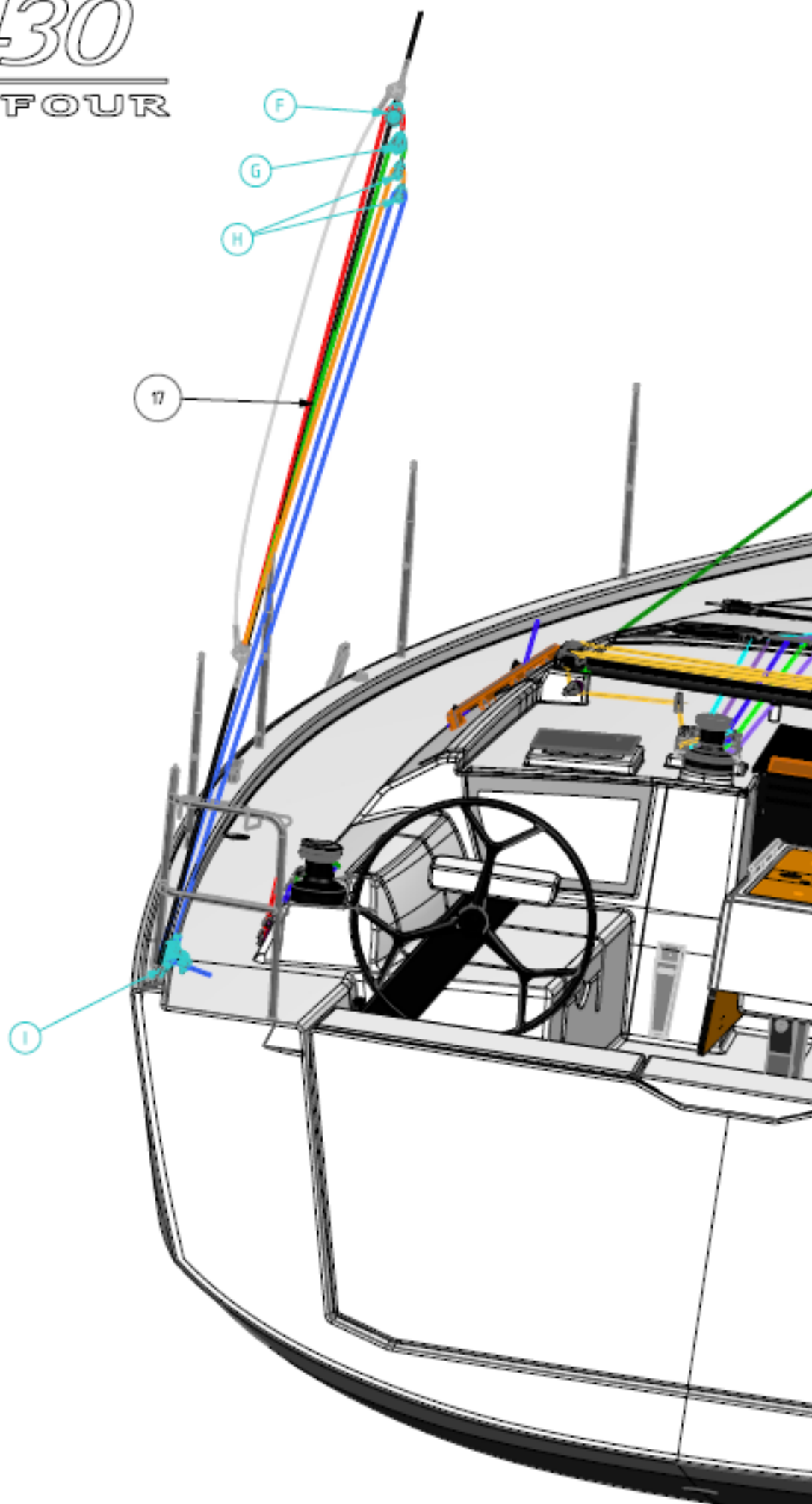

29. 220V circuit diagram

<i>Label</i>	<i>Description</i>
	<i>Facilities</i>
A	220V Shore cable**
B	Shore AC connection
C1	Aft cabin cabinet with main circuit breaker
C2	Chart table cabinet
D1	Standard auxiliary - engine charger
D2	Optional charger – Windlass*
E	Watertight water heater socket
F	Water heater
G	220V 10A outlets
H	Voltage presence connector
J1	3-way distribution connector
J2	6-way distribution connector
J3	12-way distribution connector
	<i>Electrical wiring colours</i>
<i>b</i>	light blue
<i>g</i>	green
<i>m</i>	brown
<i>n</i>	black
<i>r</i>	red
<i>v</i>	green/yellow
<i>w</i>	white
*	Option
**	Not supplied

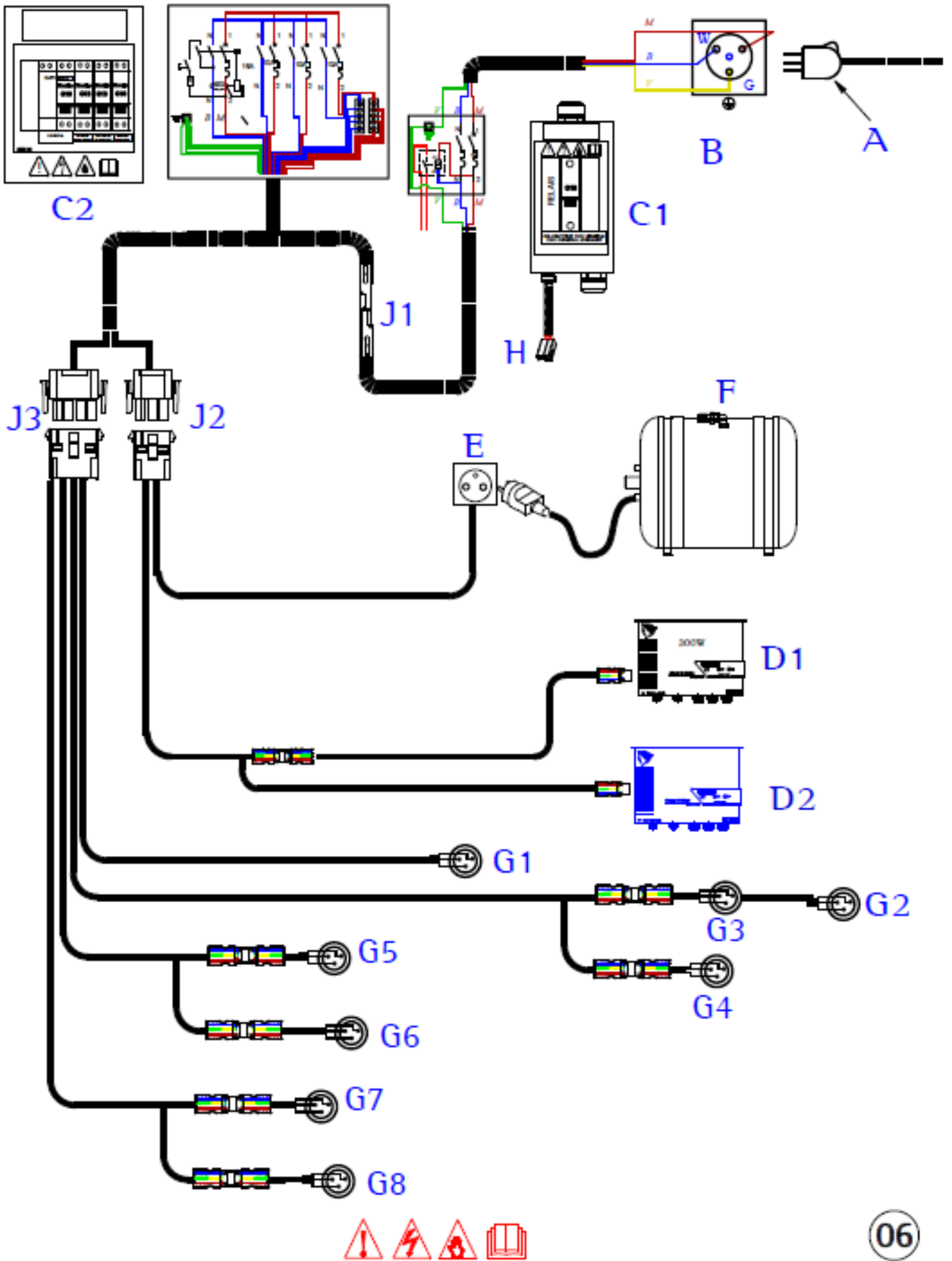

30. Charging and power system diagram

<i>Label</i>	<i>Description</i>
A	Windlass*
B	Windlass control* (remote)
C	Remote control relay*
D	8 A fuse – battery levels
E	Standard charger
E1	Windlass charger*
F	12V distribution panel
G	Single-pole 110 A circuit breaker*
H	Auxiliary batteries
I	160A fuse
J	Auxiliary batteries switch
K	5A fuse*
L	Alternator
M	Distributor
N	Starter
O	Engine battery
P	Engine battery isolator
Q	Windlass relay*
R	Bilge fan relay
S	5A fuse
T	Bilge fan
U	Windlass battery*
V	Windlass battery isolator*
B-	Terminal - (electrical panel)
T+	Terminal + (electrical panel)
Z-	Terminal - (technical area)
*	Option

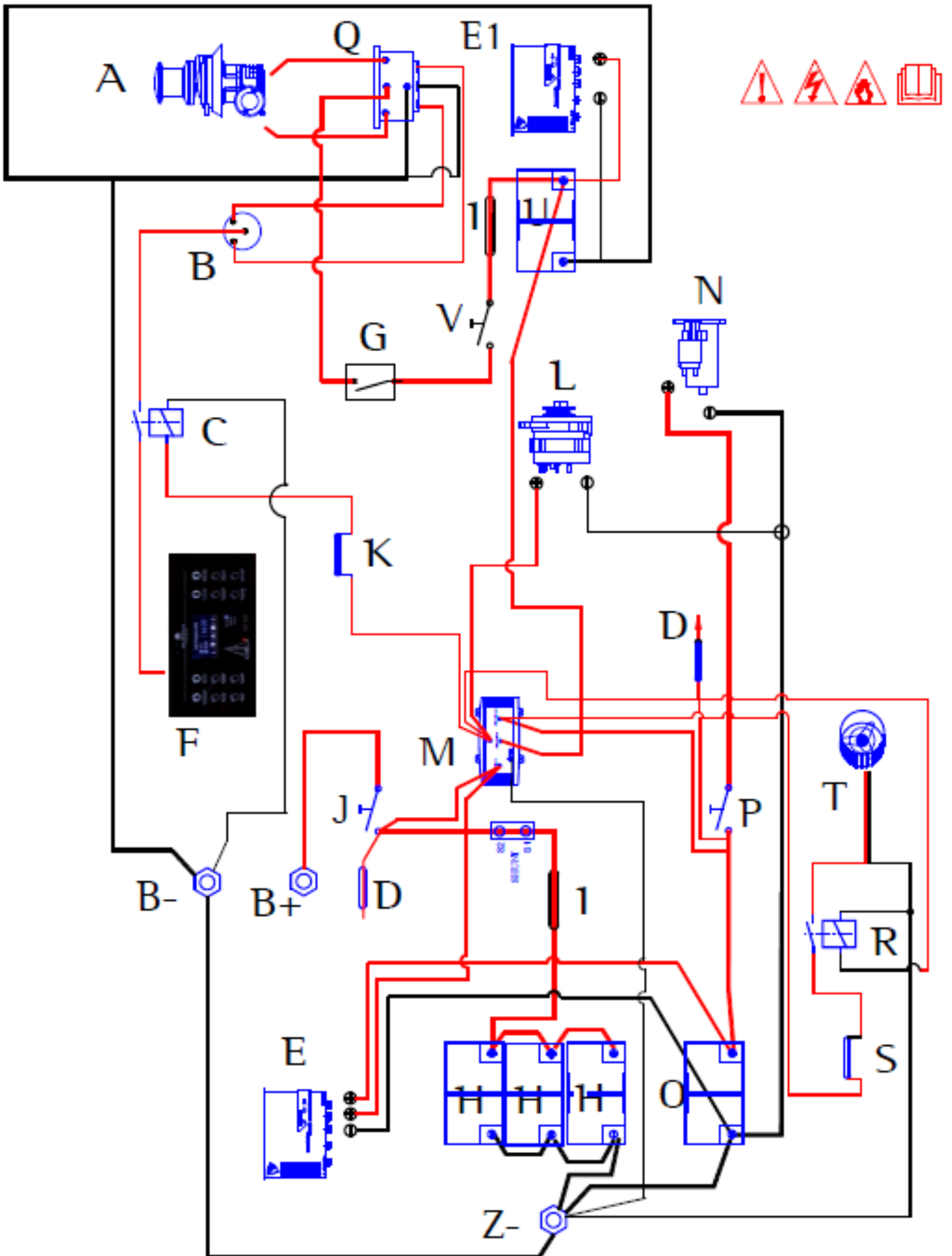

07

31. 12V electric panel

Label	Functions	Fuse code	Cut-off value
1	Navigation lights	FU15	5A
	Steaming light	FU17	5A
	Mooring light	FU16	5A
2	Auto-pilot	FU13	20A
3	Windlass control	FU14	10A
4	Deck light	FU8	10A
5	Instruments Navigation 1	FU7	10A
	Instruments Navigation 2	FU9	20A
6	Audio	FU10	10A
	Cabin USBs	FU12	10A
7	Saloon lights	FU4	15A
8	Water pump unit	FU5	10A
	Shower pumps	FU6	10A
9	Interior fridge	FU11	10A
10	Cabin lights	FU2	15A
11	Bilge pump	FU1	15A
12	Cockpit fridge	FU3	10A
13	Display screen	FU18	2A
14	Source indicator	AC supply	
15	Frontal USB socket		
16	Navigation lights indicator		

N.B.: depending on the type of boat or options, some features may not be active.

DUFOUR
YACHTS



1
NAVIGATION LIGHTS
FEUX DE NAVIGATION



4
DECK LIGHTS
FEUX DE PORT



2
AUTO PILOT
PILOTE AUTO



5
INSTRUMENTS
INSTRUMENTS



3
WINDLASS
GUINDEAU



6
HIFI SYSTEMS
SYSTEMES HIFI



7
SALOON LIGHTS
ECLAIRAGE CABINE



10
CABINS LIGHTS
ECLAIRAGE CABINES



8
WATER SYSTEMS
GROUPE D'EAU



11
BILGE PUMP
POUMPE DE CALE



9
GALLEY FRIDGE
REFRIGERATEUR



12
COCKPIT FRIDGE
FRIGO DE COCKPIT

Lundi 10 Septembre 2018

36,3 °C

1022 hPa

16:35

13

14

SHORE POWER

GENERATOR

INVERTER

15

16

32. Electrical panel rear wiring

Function switches

Position	Status
0	Disabled function
I	Forced Mode Function
II	Panel Mode Function – activated by the front

Label	Function
S1	Sailing Instruments
S2	Deck light
S3	Cockpit fridge
S4	Windlass control
S5	Audio / USB sockets
S6	Auto-pilot
S7	Interior fridge
S8	Cabin Lights
S9	Saloon Lights
S10	Navigation lights
S11	Bilge pump
S12	Water / shower pump unit
S13	Steaming light
S14	Mooring light

Connectors

K connectors

Label	Function
K1	AC Source Indicator – Shore Cable
K2	AC Source Indicator – Inverter
K3	AC Source Indicator – Generator
K4	Auxiliary and Optional battery installation voltage indicator
K5	Greywater holding tank level indicator
K6	CAN bus
K7	RS485 bus
K8	LIN bus

N.B.: depending on the type of boat or options, some features may not be active

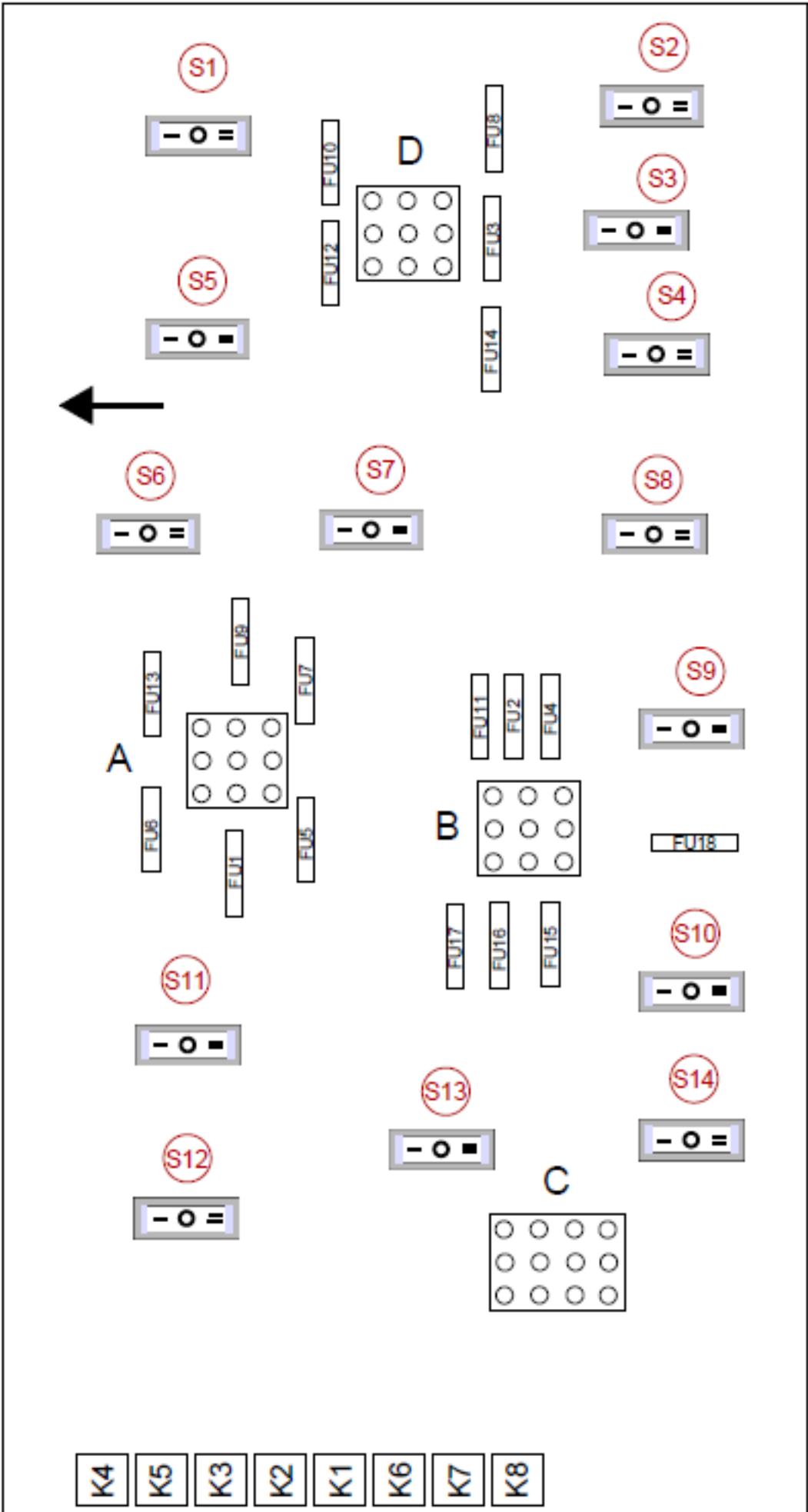

Power Connectors – A – B – D

Label	Type	Definition
A1	Outlet	Water pump unit
A2	Inlet	AUXILIARY BATTERIES
A3	Outlet	Interior fridge
A4	Outlet	Bilge pump
A5	Inlet	AUXILIARY BATTERIES
A6	Outlet	Navigation Instruments 2
A7	Outlet	Shower pump
A8	Inlet	GND
A9	Outlet	Auto-pilot
B1	Outlet	Navigation lights
B2	Inlet	AUXILIARY BATTERIES
B3	Outlet	Saloon Lights
B4	Outlet	Mooring light
B5	Inlet	AUXILIARY BATTERIES
B6	Outlet	Cabin Lights
B7	Outlet	Steaming light
B8	Inlet	GND
B9	Outlet	Audio System
D1	Outlet	Deck light
D2	Inlet	AUXILIARY BATTERIES
D3	Outlet	Navigation Instruments 1
D4	Outlet	Cockpit Fridge
D5	Inlet	AUXILIARY BATTERIES
D6	Outlet	USB sockets
D7	Outlet	Windlass control
D8	Inlet	GND
D9		FREE

Signal Connectors – C

Label	Type	Value	Definition
C1	Inlet	-50 mV	100A shunt
C2	Inlet	+50 mV	100A shunt
C3	Inlet	0-180Ω	No.3 WATER Tank Level
C4	Inlet	0-180Ω	No.1 WATER Tank Level
C5	Inlet	□□0-180Ω	No.1 FUEL Tank Level
C6	Inlet	0-14V	Engine Battery Voltage
C7	Inlet	0V	GND
C8	Inlet	0-180Ω	No.2 FUEL Tank Level
C9	Inlet	0-180Ω	No.2 WATER Tank Level
C10	Inlet	0-180Ω	No.1 Holding Tank Level
C11	Inlet	0-180Ω	No.2 Holding Tank Level
C12	Inlet	0-180Ω	No.3 Holding Tank Level

N.B.: depending on the type of boat or options, some features may not be active

A

7	8	9
4	5	6
1	2	3

B

7	8	9
4	5	6
1	2	3



D

9	6	3
8	5	2
7	4	1

C

3	2	1
6	5	4
9	8	7
12	11	10

33. 12V electrical installation diagram

A-3-cabin front galley version

B-4-cabin long galley version

<i>Label.</i>	<i>Description</i>
1	Windlass*
2	Windlass relay*
3	Windlass remote control*
4	Navigation lights*
5	Fresh-water gauge
6	Reading lights
7	Water pump unit
8	Saloon speaker*
9	12V electric panel
10	Flexible LED switch
11	USB socket
12	Submersible bilge pump
13	Steaming light
14	Mooring light
15	Saloon downlight
16	Saloon downlight switch
17	Galley downlight switch
18	Galley downlights
19	Refrigeration unit
20	Shower waste pump
21	Windlass battery*
22	Windlass circuit breaker*
23	Bathroom downlight
24	Courtesy lights
25	Engine battery
26	Auxiliary batteries
27	Fuel gauge
28	Motor fan
29	Alternator
30	Engine and auxiliary battery isolator
31	Distributor
32	Starter
33	NA
34	Seawater pump
35	Exterior speaker*
36	Steering compass
37	Auto-pilot motor*
38	Courtesy lights switch
39	Seawater pump switch
*	Option

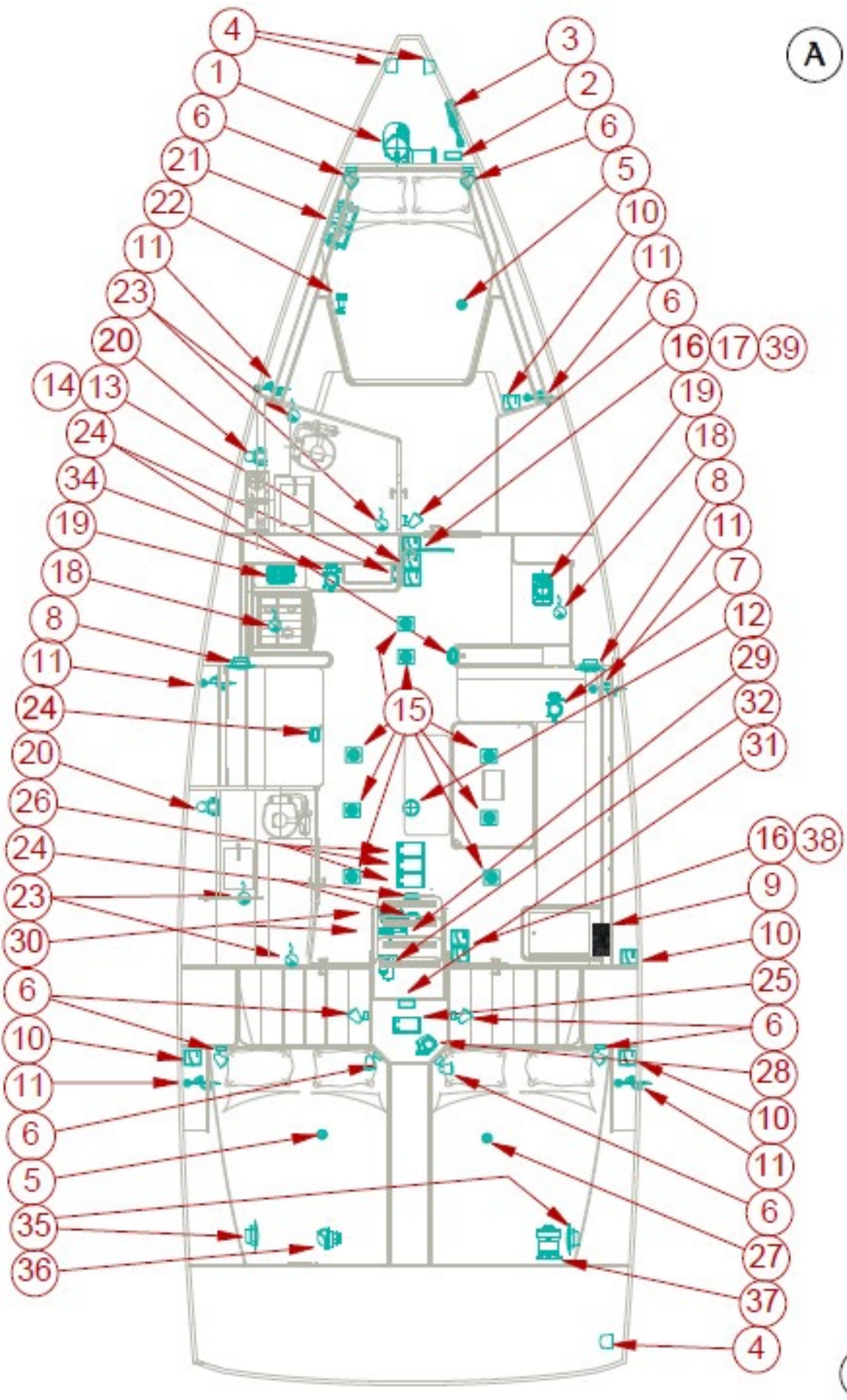

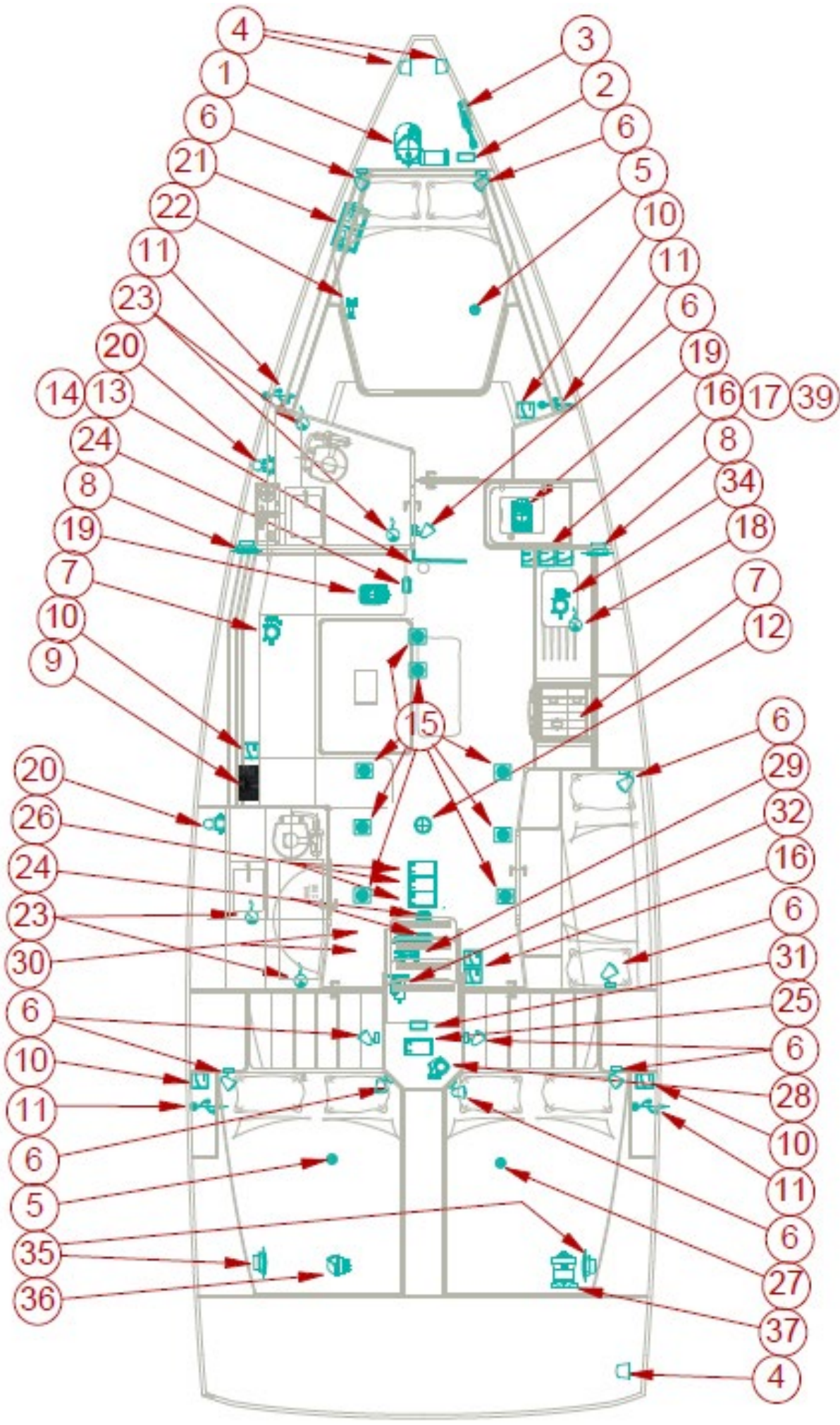

11- 220V electrical installation diagram

A- 3-cabin front galley version

B- 4-cabin long galley version

<i>Label</i>	<i>Description</i>
1	220 V (or 110 V) power socket
2	Water heater
3	Battery charger
4	Main circuit breaker box
5	E/F/G connectors
6	Shore AC connection
7	220V Microwave power socket*
8	General circuit breaker box
9	Optional charger – Windlass*
*	Option

A

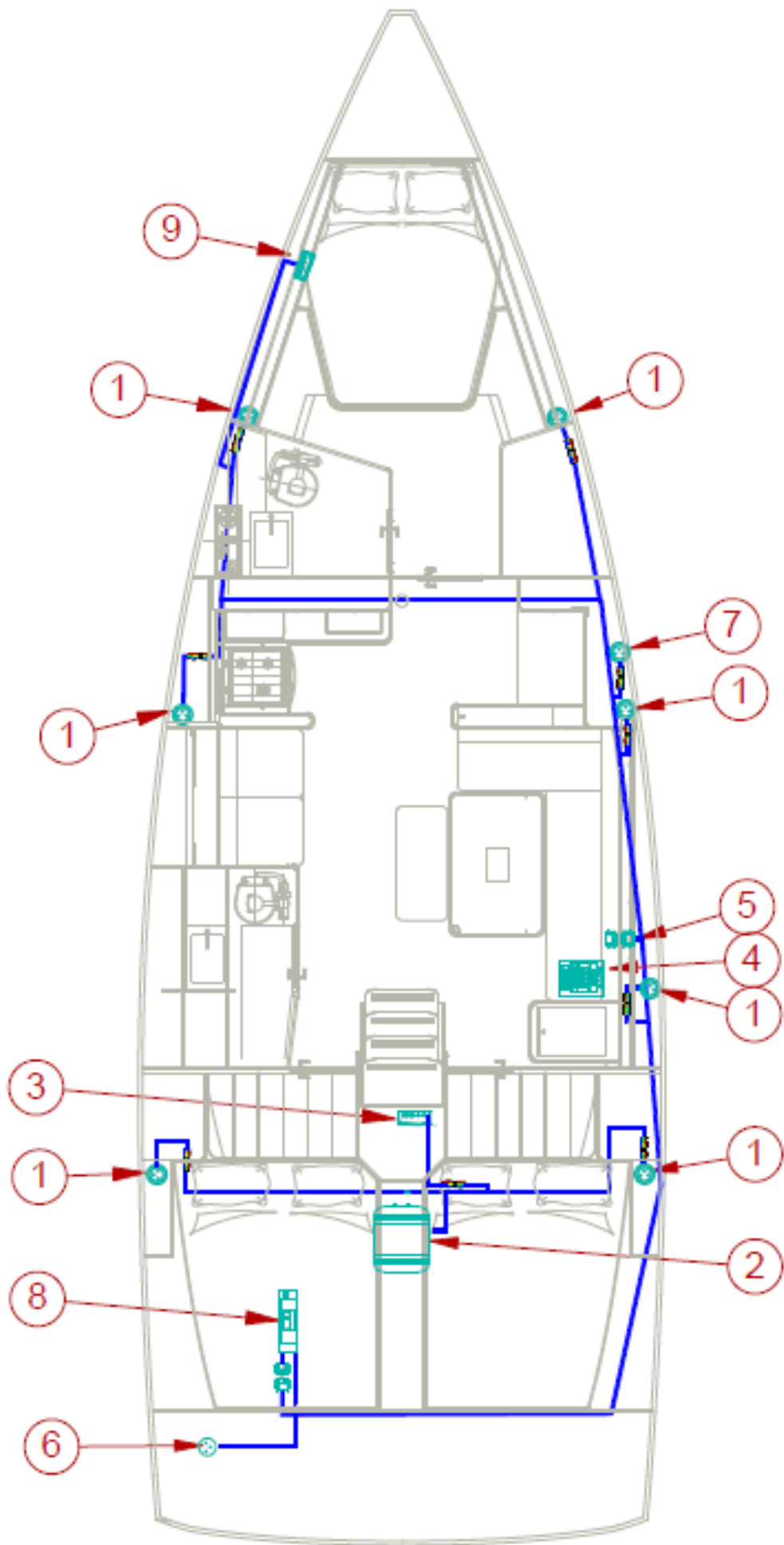

11

B

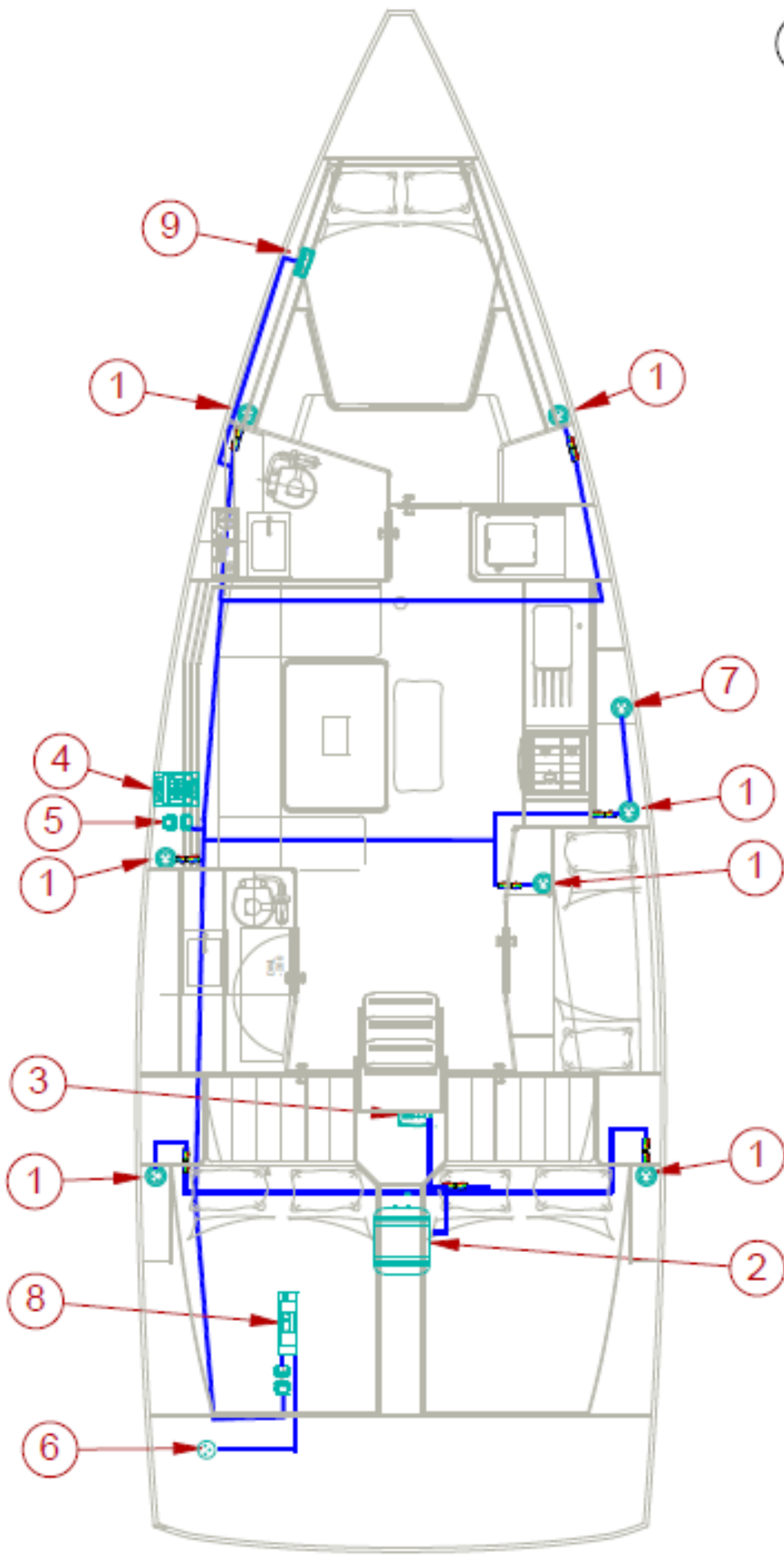

11

12- Fuse location diagram

A-3-cabin front galley version
B-4-cabin long galley version

<i>Label</i>	<i>Description</i>
A	<p><i>Zone A - 12V</i></p> <p>Strip fuse 500A: optional bow thruster*</p> <p>Differential circuit-breaker 110A: windlass*</p>
B	<p><i>Zone B - 12V</i></p> <p>Blade fuse 1A: with gas solenoid valve*</p> <p>Blade fuse 10A: heating option*</p> <p>Blade fuse 5A: bow thruster option*</p> <p>Blade fuse 10A: VHF option*</p> <p>Blade fuse 30A: inverter option*</p> <p>Resettable circuit breaker type C 16A: Electric toilets*</p>
C	<p><i>Zone C - 12V</i></p> <p>Blade fuse 10A: bilge fan</p>
D	<p><i>Zone D - 12V</i></p> <p>Strip fuse 160A: panel protection</p>
E	<p><i>Zone E - 220V General electrical box</i></p> <p>16A/30mA differential circuit breaker: general protection</p> <p>Phase/Neutral thermomagnetic circuit breaker 10A: water heater protection</p> <p>Phase/Neutral thermomagnetic circuit breaker 10A: charger protection</p> <p>Phase/Neutral thermomagnetic circuit breaker 10A: 220V socket protection</p>
F	<p><i>Zone F - 12V</i></p> <p>35A strip fuse: Electric aft gate*</p>
G	<p><i>Zone F: 220V</i></p> <p>General circuit breaker: shore protection</p>
*	OPTION

A

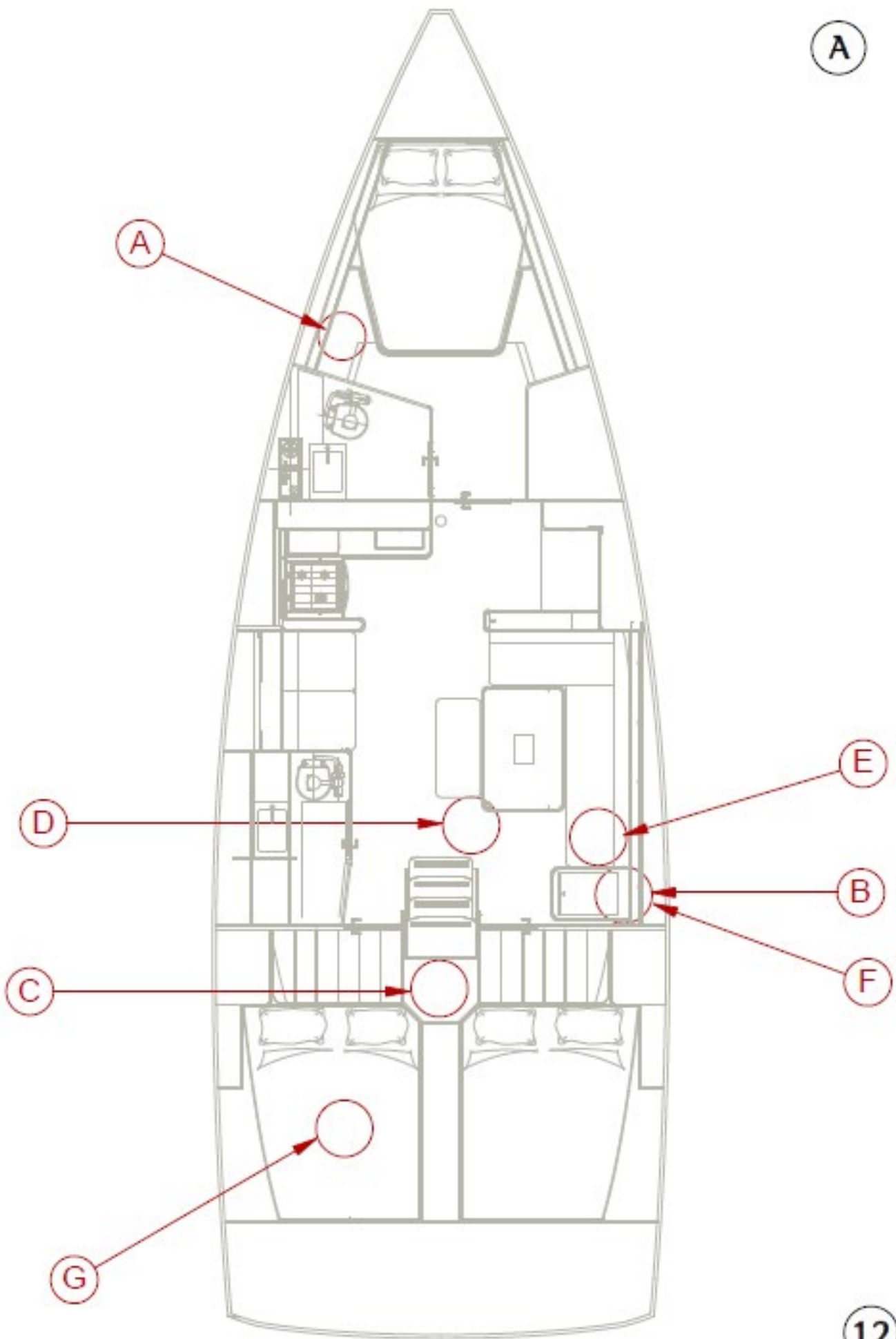

12

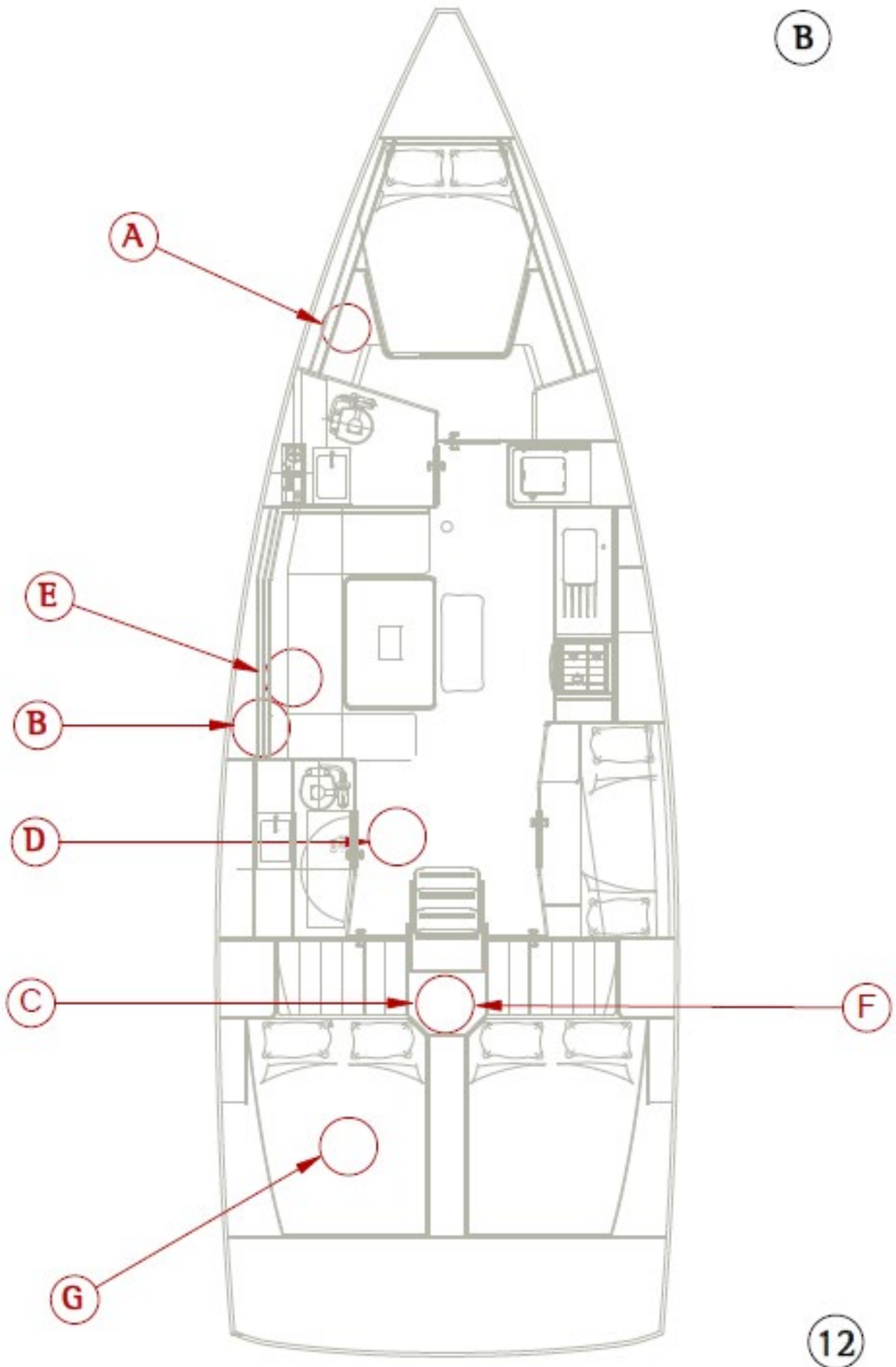

13 - Steering system diagram

<i>Label</i>	<i>Description</i>
1	Rudder blade + stock
2	Rudder trunk
3	Lower bearing
4	Lower bearing and rudder rings
5	Top bearing
6	Section stop
7	Steering wheel
8	Autopilot motor*
9	Helm angle indicator*
10	Emergency tiller
11	80 degree segment
12	Port and starboard helm pedestals
*	Option

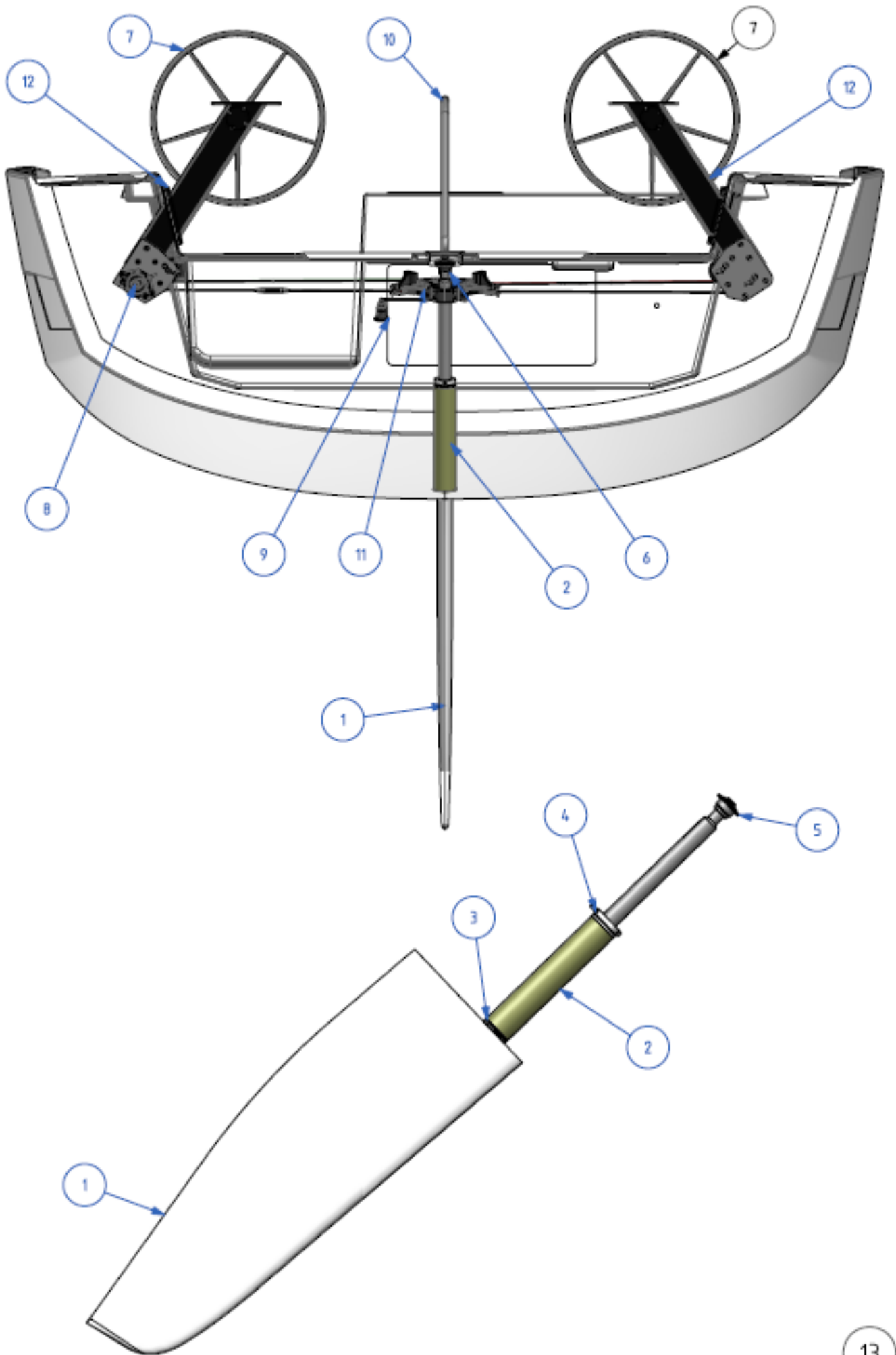

14 - Gas system diagram

A-3-cabin front galley version
B-4-cabin long galley version

<i>Label</i>	<i>Description</i>
1	1.8 kg gas cylinder**
2	CE shut-off valve (Fr. or Ger.)
3	30mbar CE regulator valve (Fr. or Ger.) / pressure gauge
4	Medium-length connecting hose
5	Spacer/tube 6 x 8
6	Watertight bulkhead fitting
7	PVC pipe
8	6 x 8 copper pipe
9	CE gas shut-off valve
10	Long connection hose
11	Cooker/Oven
12	Bulkhead gas locker
13	"T" gas connector*
14	Foldaway*
15	Split black sleeve
16	Gas foldaway hose *
*	Option
**	Not supplied

A

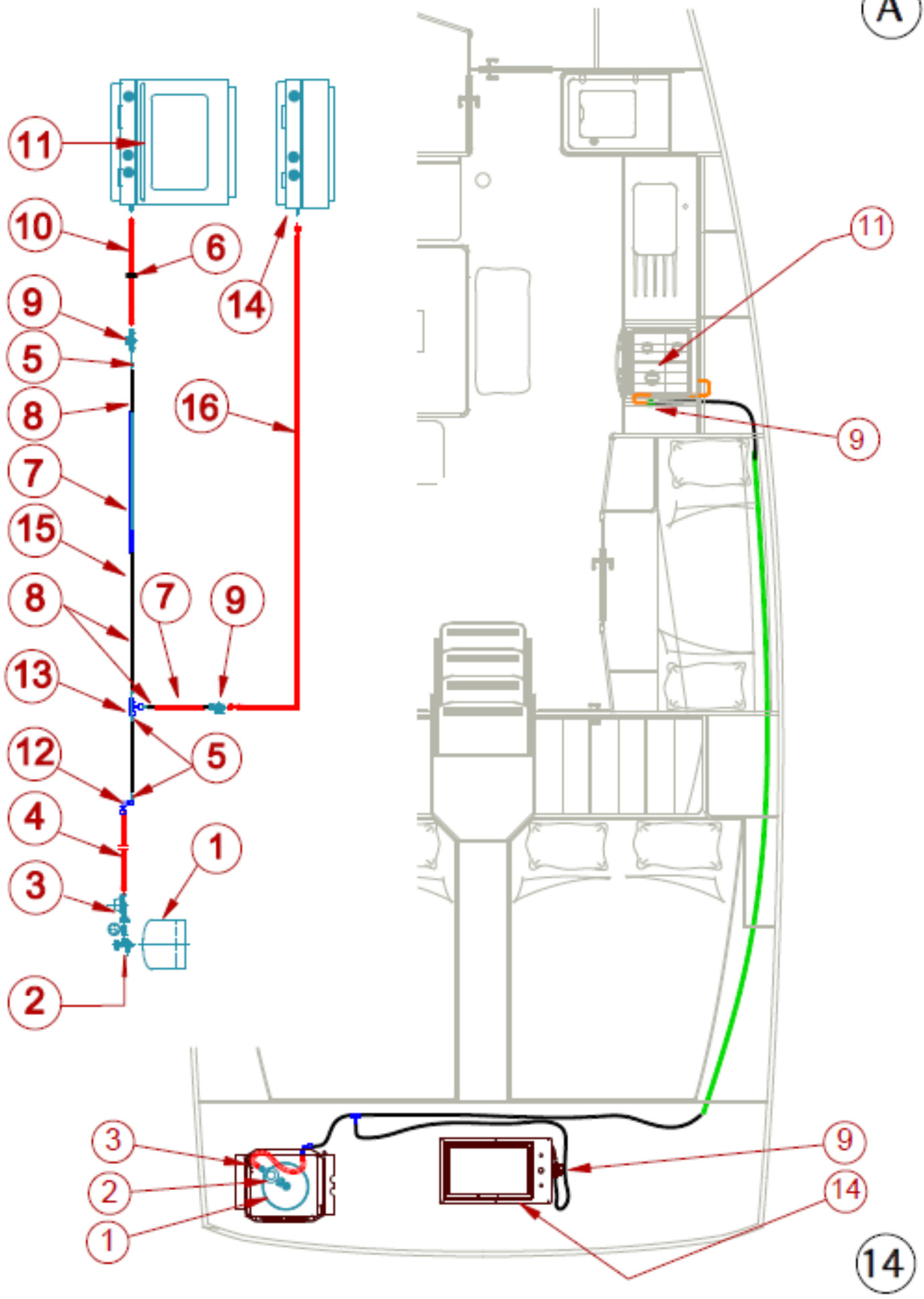

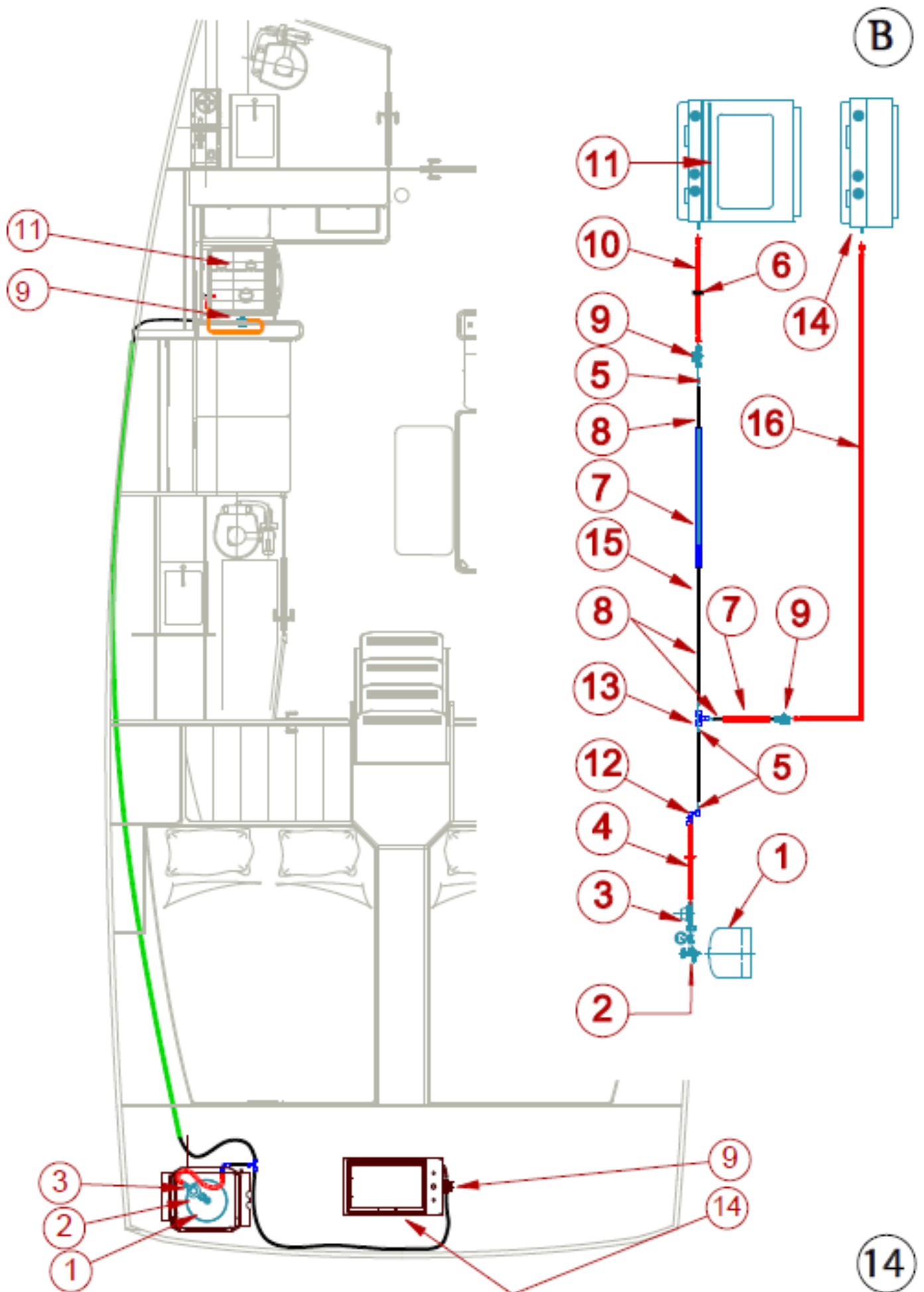



15- Abandon ship plan

A-3-cabin front galley version

B-2-cabin long galley version

<i>Label</i>	<i>Description</i>
	Recommended fire-extinguisher locations
1	1 kg powder fire extinguisher 5A/34B **
2	1 kg powder fire extinguisher 5A/34B **
Wh	Engine compartment extinguisher hole
SD	Fire Detector - recommended location
	Emergency exit
	Fire blanket (recommended location)
**	Not supplied

B

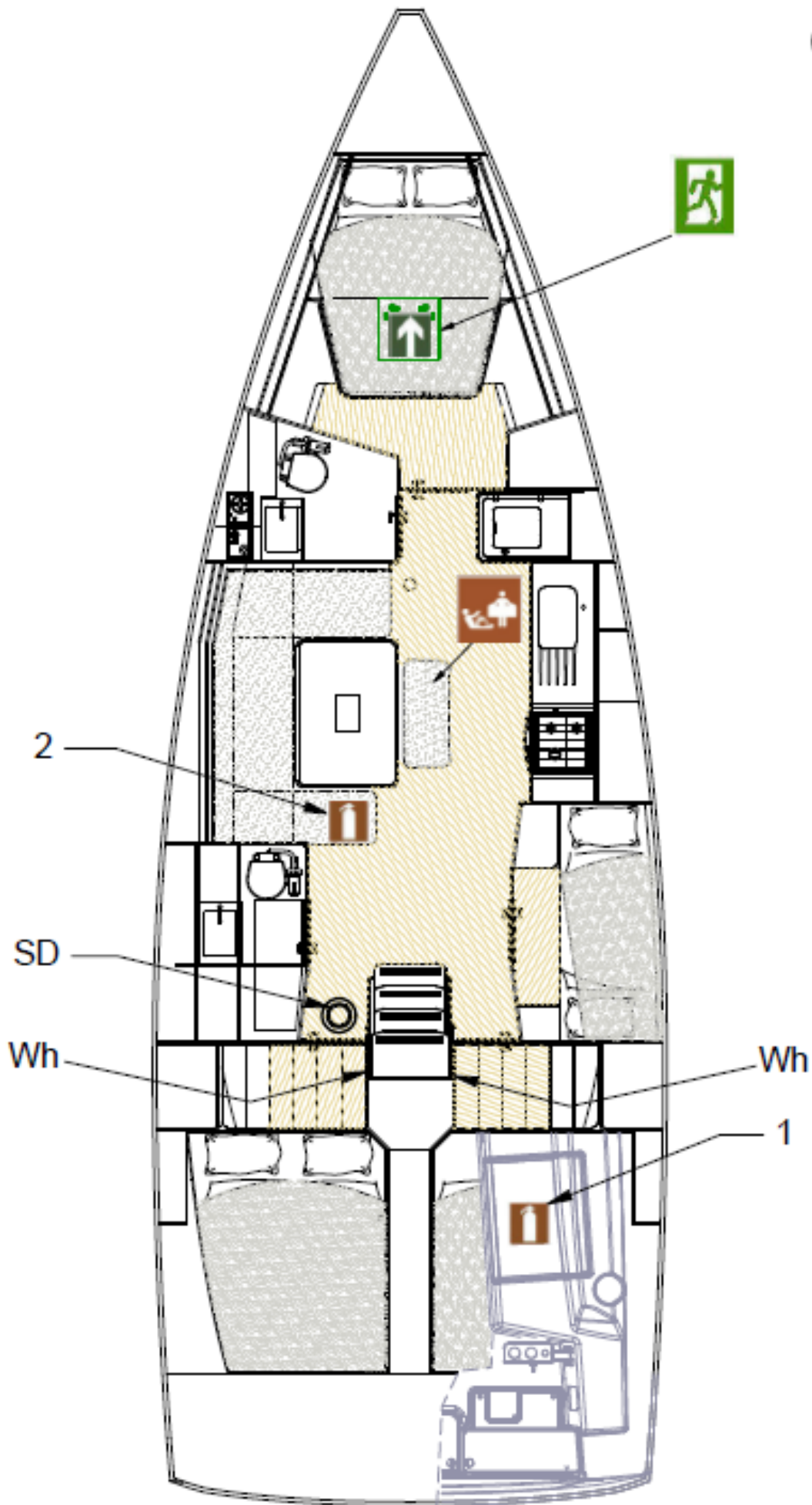

15

16- Freshwater system diagram

A-3-cabin front galley version

B-4-cabin long galley version

<i>Label</i>	<i>Description</i>
1	Filler deck plate
2	Filler hose
3	Vent
4	Vent hose
5	Fore water tank, 180 L
6	Stern water tank 250 L
7	Hot water pipe
8	Cold water pipe
9	Pressurized water pump unit
10	Fresh-water pump
11	Water heater
12	Head shower single-lever mixer tap
13	Galley single-lever mixer tap
14	Deck shower
15	Water tank selection valves
16	1/2" 3-way manifold
17	3/4" male brass cap
18	1/4 turn FF 1/2" valve
19	3/4" WX F connector
20	1/2" WX M connector
21	Seawater foot pump
22	Exterior sink tap*
*	OPTION

A

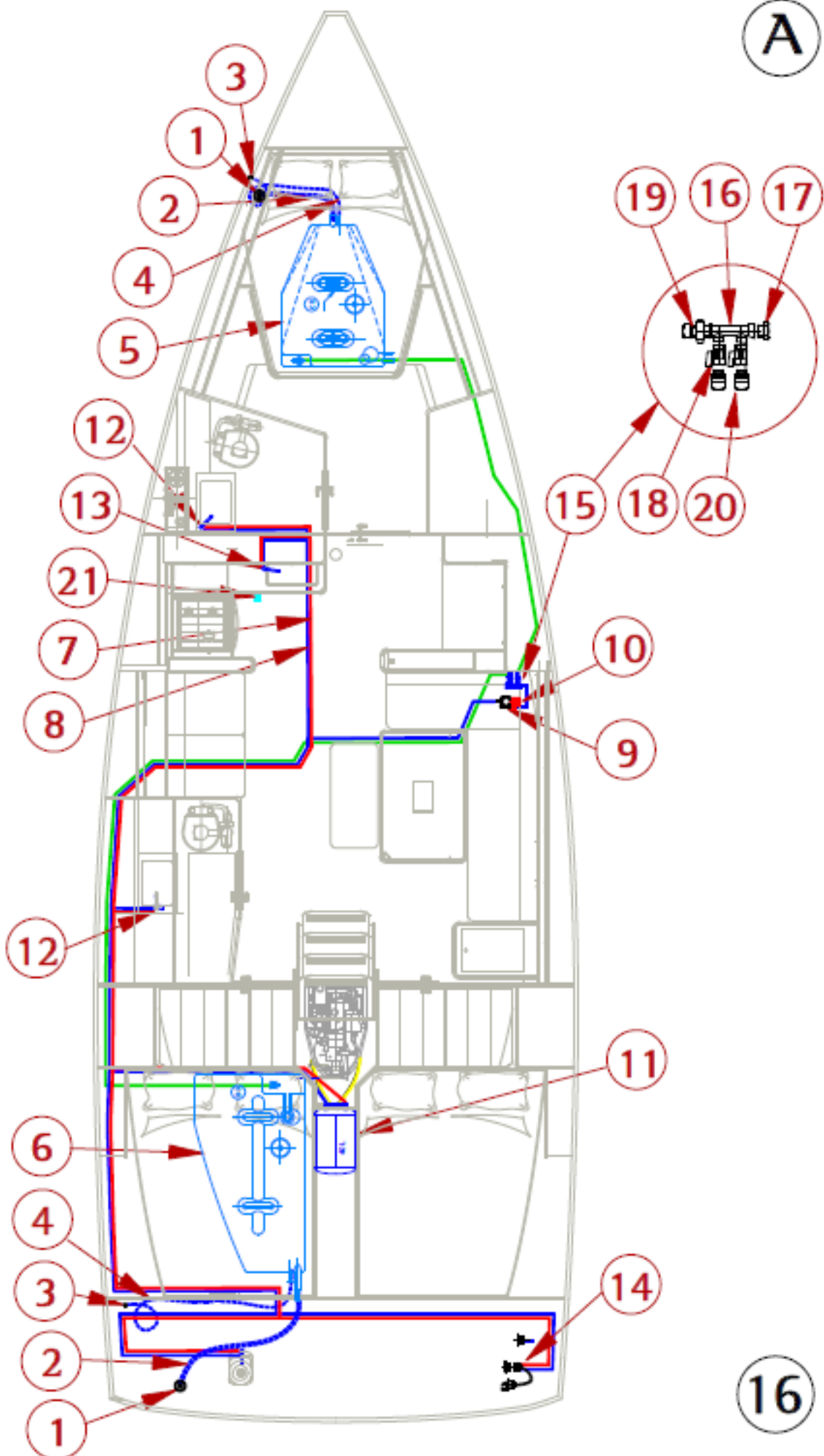

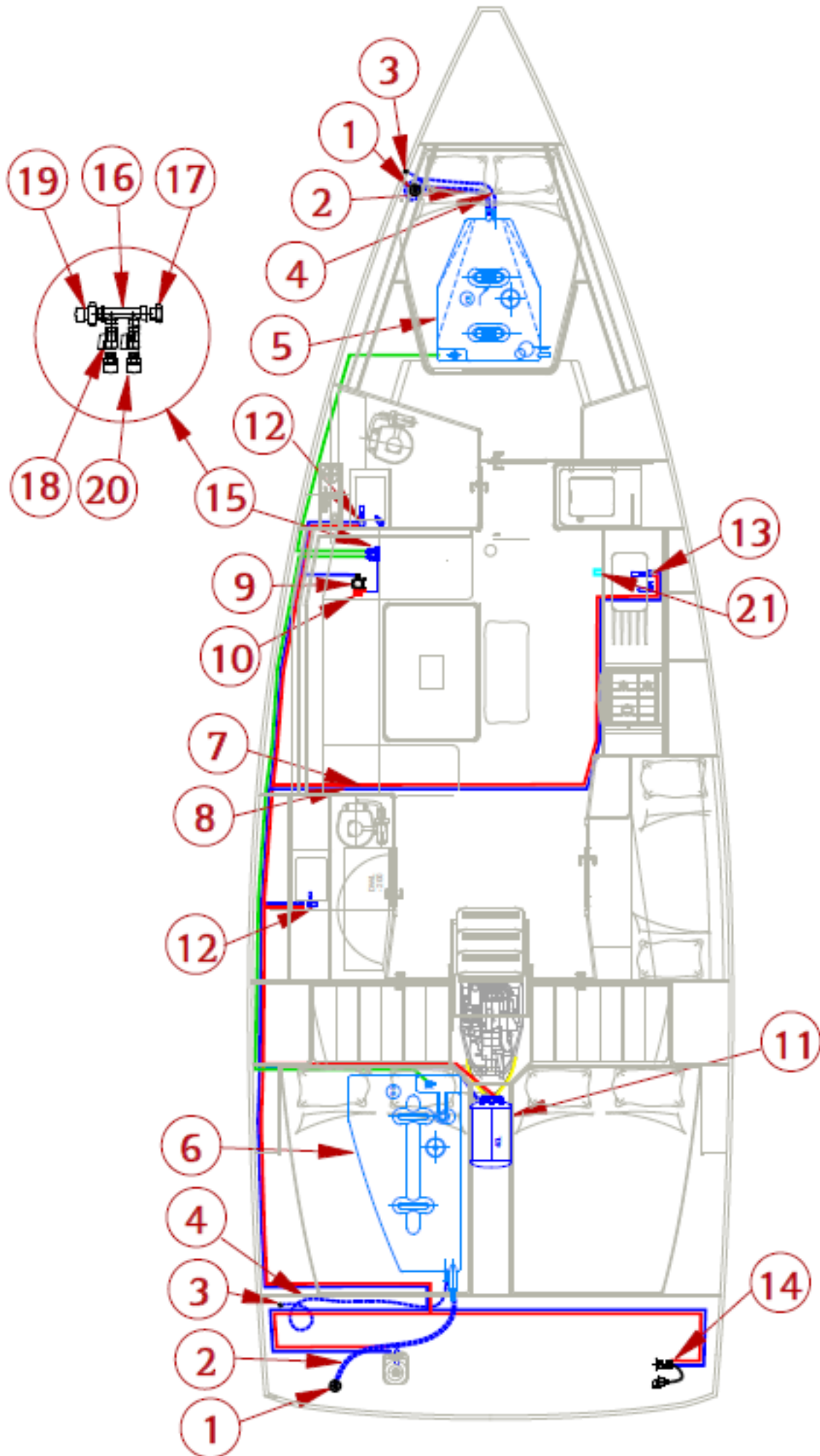

17 - Drain system diagram

<i>Label</i>	<i>Description</i>
1	<i>Electric bilge pump</i> Ø25 discharge hose
2	Submersible bilge pump
3	Skin fitting 1"
4	<i>Manual bilge pump</i> D25 Strainer with non-return valve
5	Ø25 discharge hose
6	Manual bilge pump
7	Skin fitting 1 "

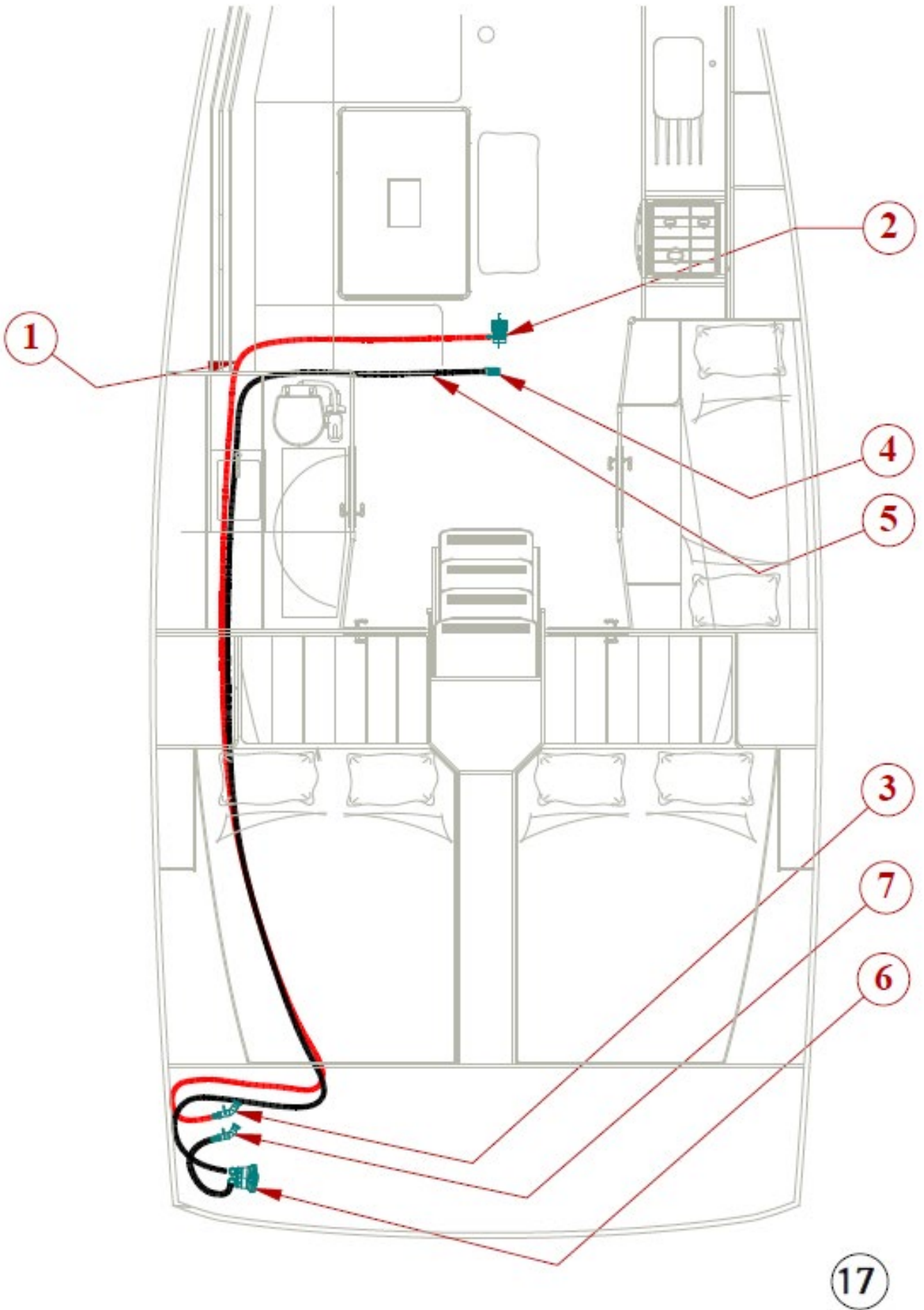

18 - Skin fitting location diagram

A - 3-cabin front galley version

B - 4-cabin long galley version

<i>Label</i>	<i>Description</i>	<i>Ø</i>
	<i>Skin fittings + seacocks</i>	
1	Galley sink discharge	1"
2	Washbasin and shower discharge	1"
3	Toilet sea-water intake	3/4"
4	Toilet discharge	1-1/2"
5	Seawater pump socket	1/2"
6	Cockpit discharge	2"
7	Exterior sink discharge and scupper	1"
8	Life raft locker discharge	1"
	<i>Skin fitting</i>	
9	Chain locker discharge	1"
10	Electric bilge pump discharge	1"
11	Manual bilge pump discharge	1"
*	Option	

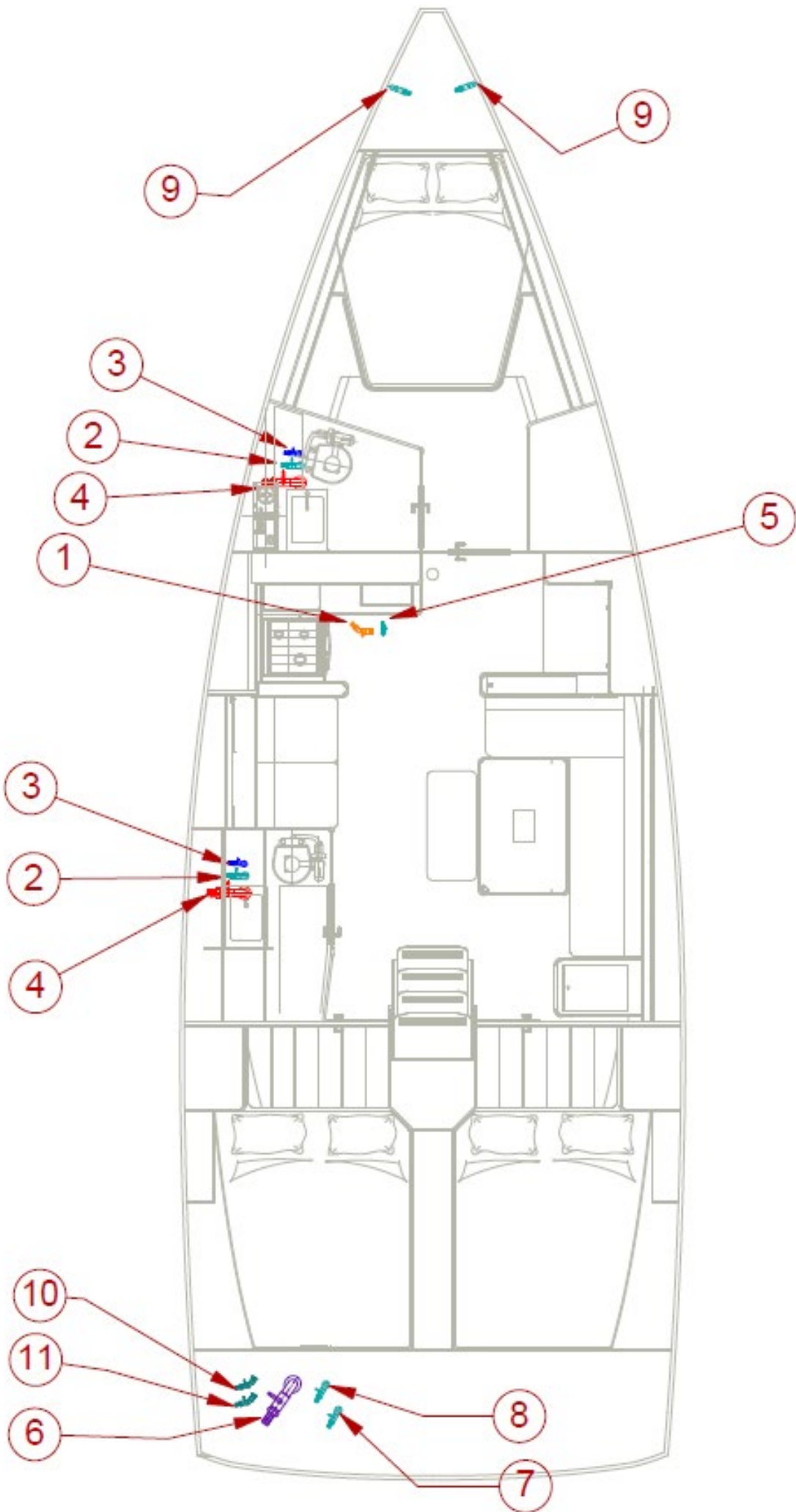

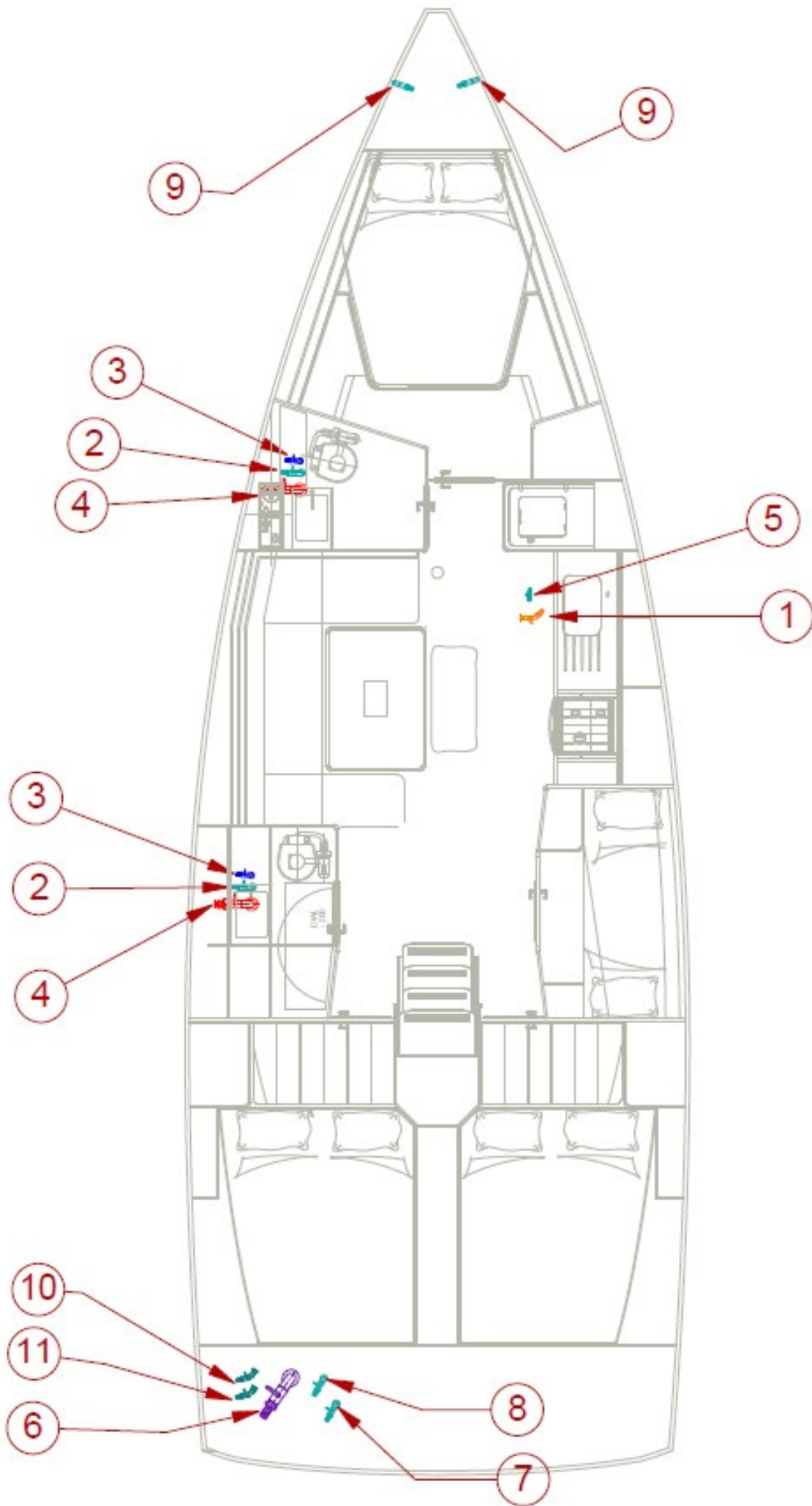

19 Mechanical installation diagram

<i>Label</i>	<i>Description</i>
1	Engine
2	Polyester frame
3	Sail Drive
4	Anode
5	Propeller
6	Foam insulation
7	Anti-siphon elbow
8	Waterlock silencer
9	Exhaust outlet
10	Bilge fan
11	Ventilation grilles
12	Starter battery
13	Isolator
14	Charge splitter
15	Engine control lever
16	Engine instruments
17	Seawater filter

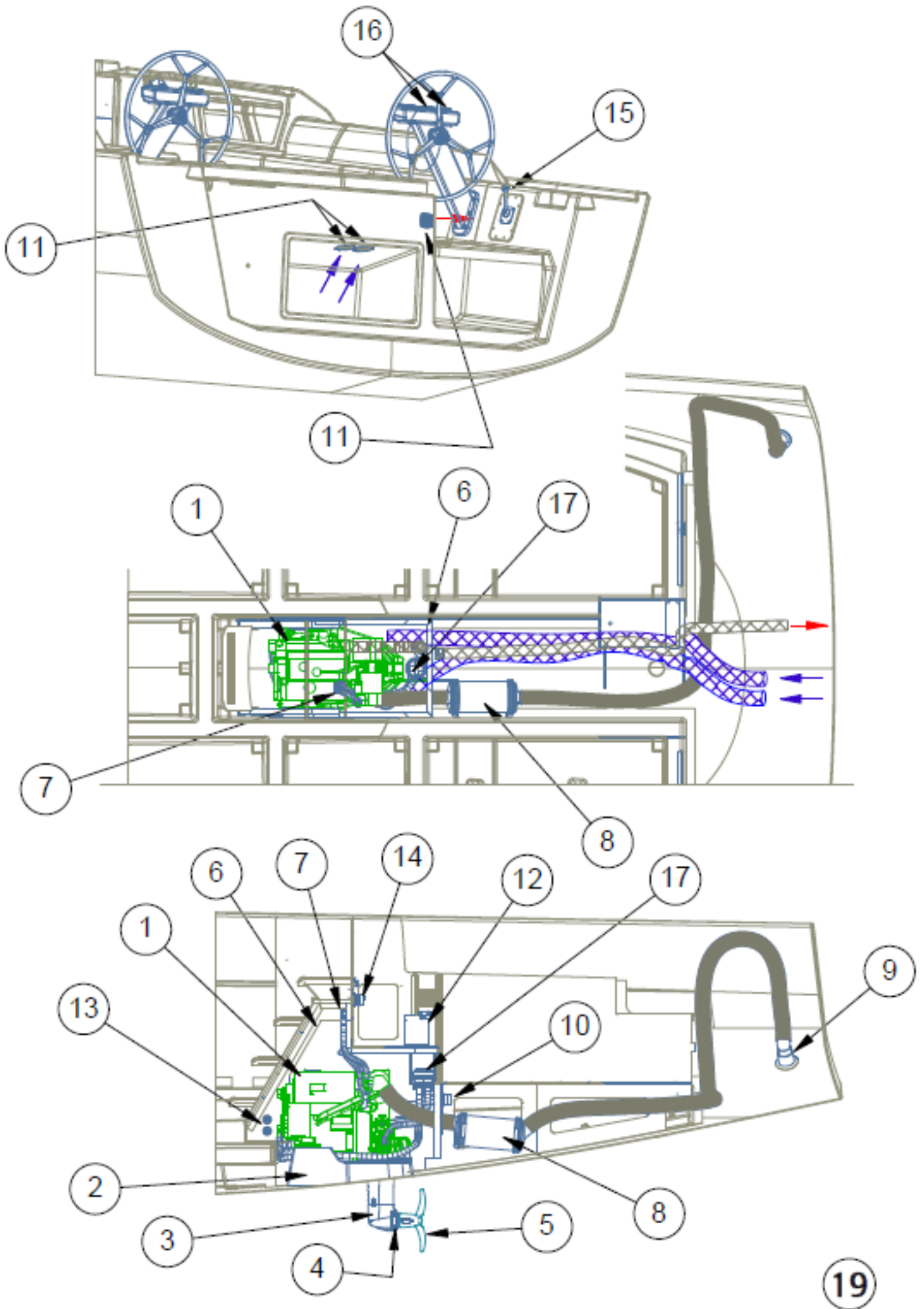

20 Gas system diagram

<i>Label</i>	<i>Description</i>
1	Diesel tank
2	Fuel shut-off valve
3	Overflow vent
4	Fuel deck plate
5	Tank vent
6	Fuel pre-filter

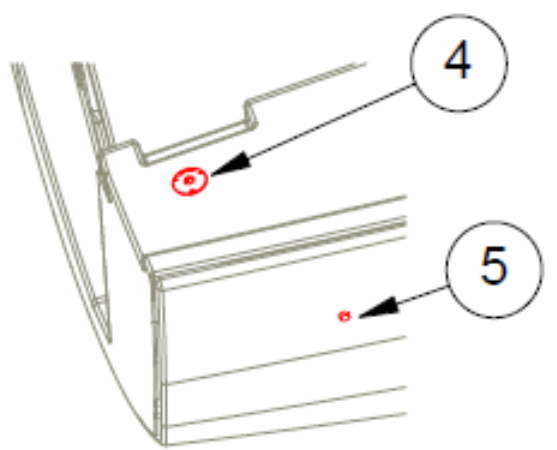
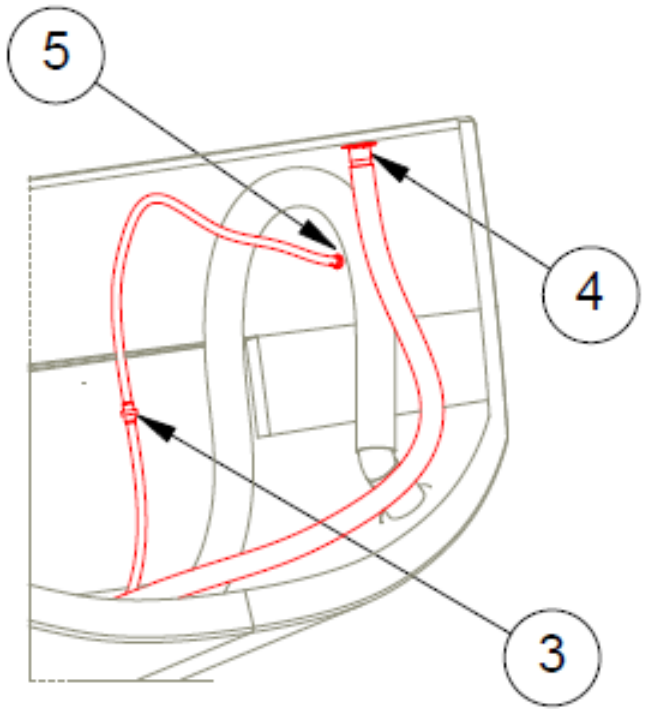
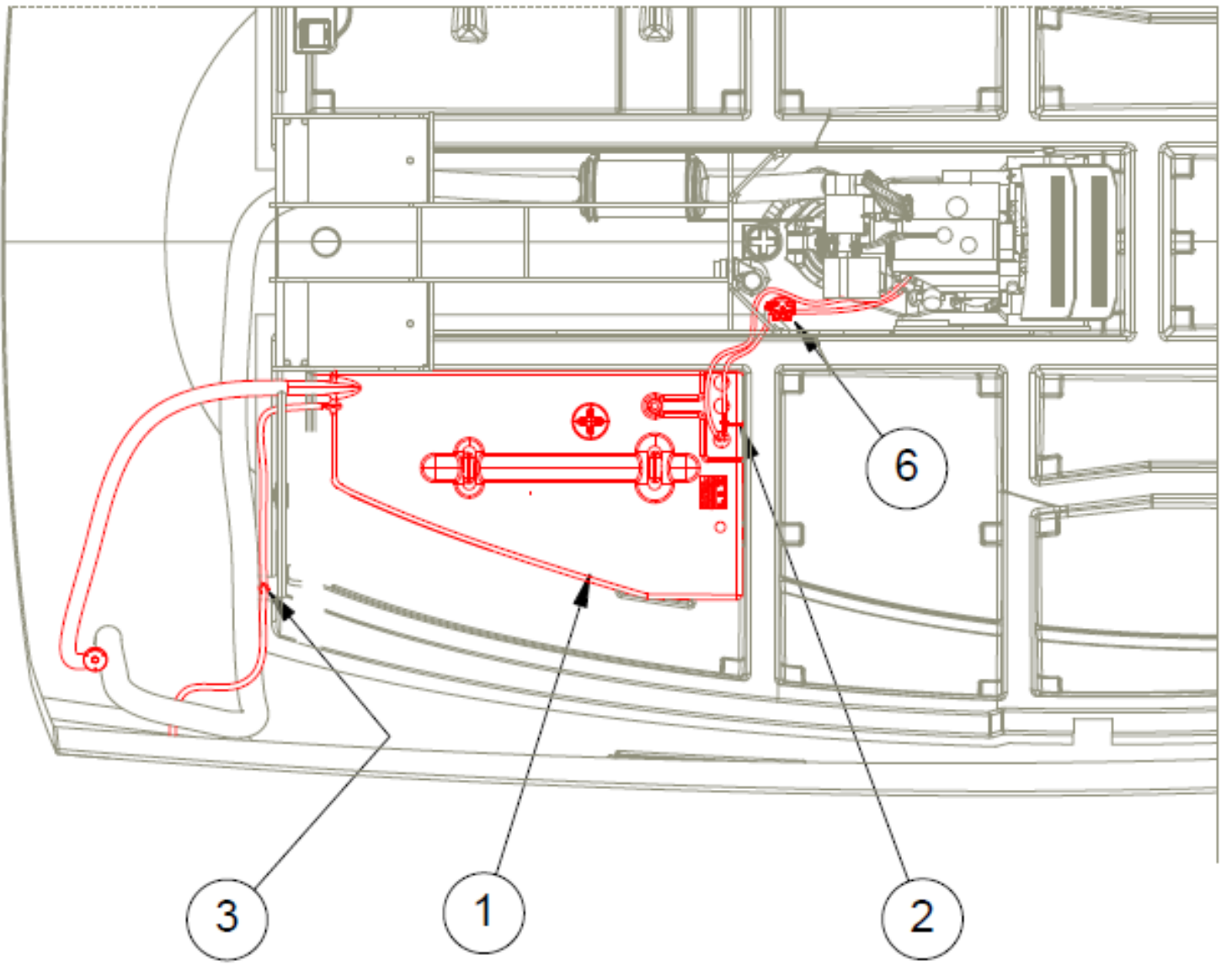

20

21 Holding tank installation diagram

<i>Label</i>	<i>Description</i>
1	3/4" cock and skin fitting
2	Black water deck plate Ø50
3	1-1/2" cock and skin fitting
4	20 mm Ø hose
5	38 mm Ø anti-odour hose
6	51 mm Ø anti-odour hose
7	3/4" chromed brass vent
8	Polyethylene holding tank, 50 L
9	Polyethylene holding tank, 45 L
X	U-bend

A

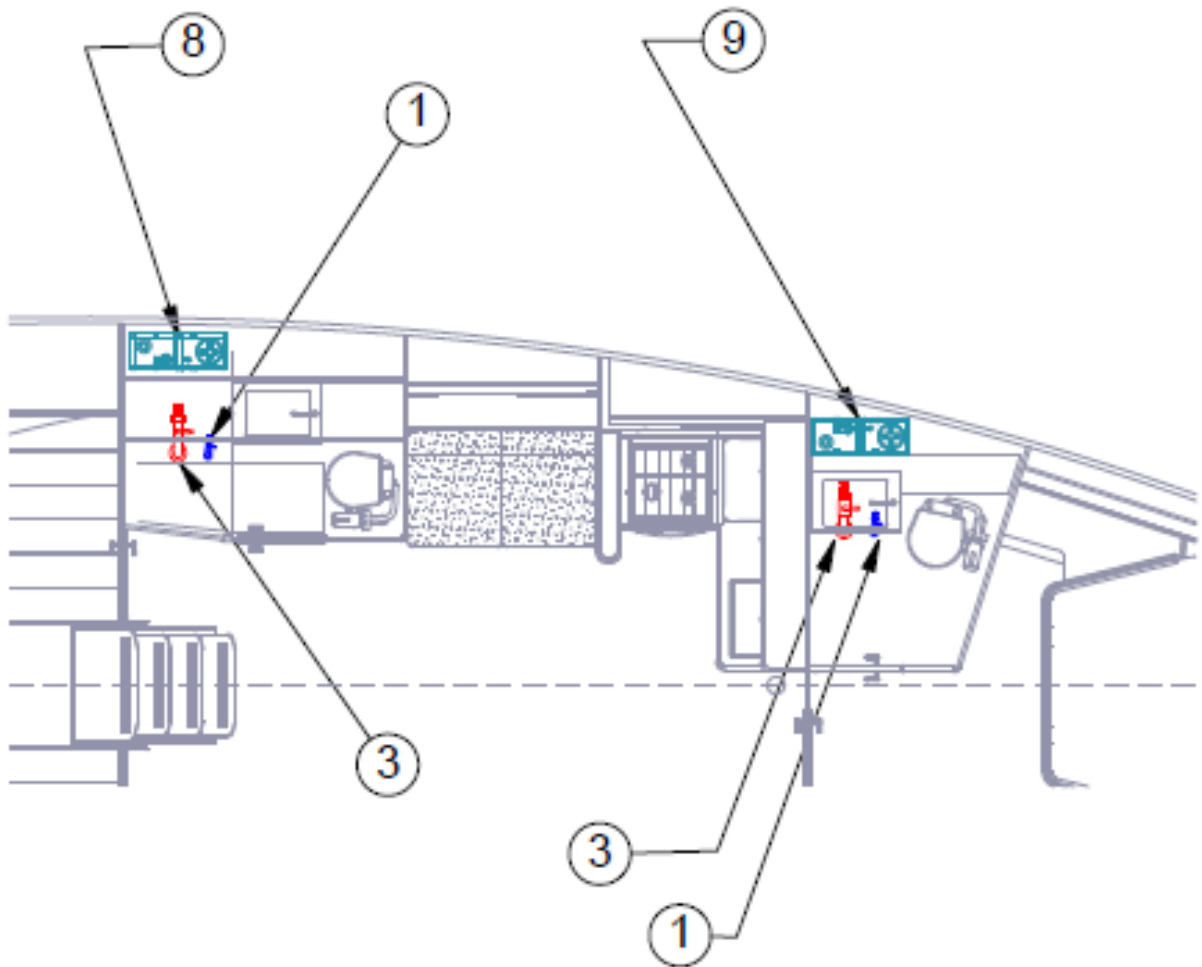
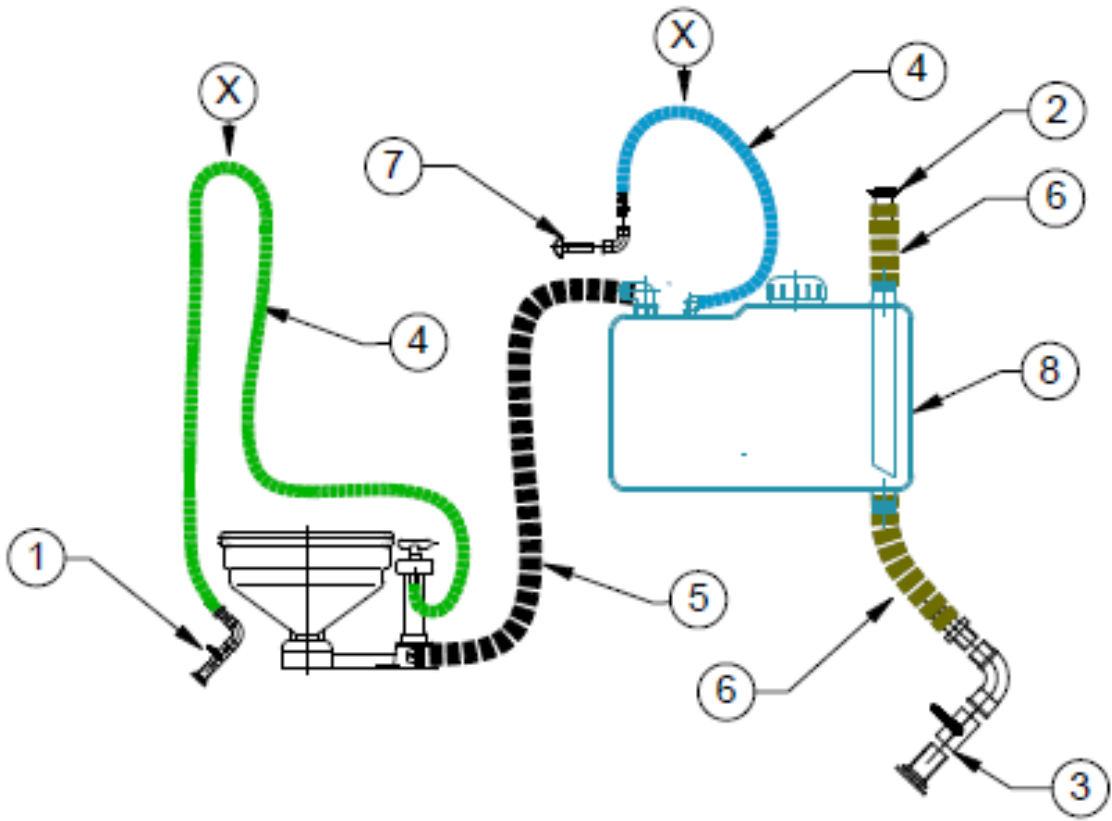

21

22 Lifting diagram

<i>Label</i>	<i>Description</i>
	<p>See red triangular marker under deck-line</p> <p>Displacement with maximum load: 12800 kg Midship beam: 4.30 m Standard draft: 2.10 m</p>

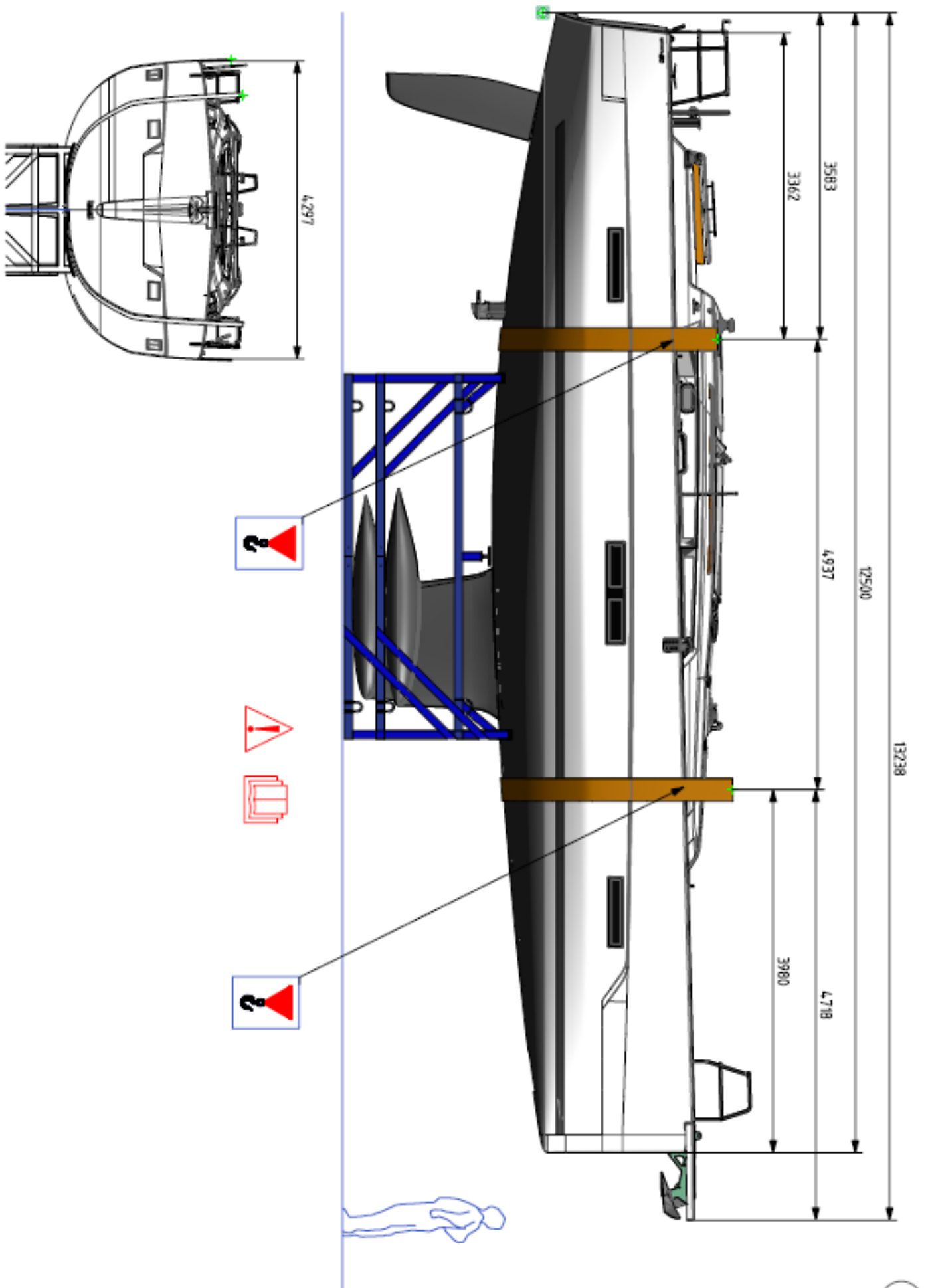

23 Navigation lights

Label	Function	Action
A	Under sail	1 st push
B	Motor sailing	2 nd push
C	Mooring	3 nd push
	Return Lights Off	4 nd push
D	Switch on 12V panel	
	Red / green bow lights	Range 2Nm
	Stern light	Range 2Nm
	Steaming light	Range 2Nm
	Mooring light	Range 2Nm

A

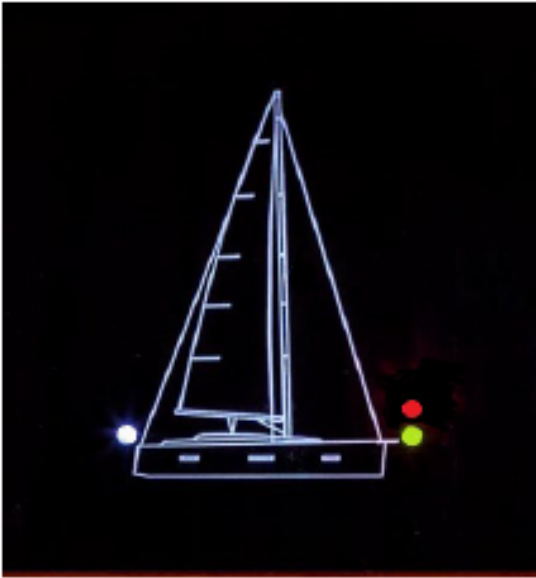

B

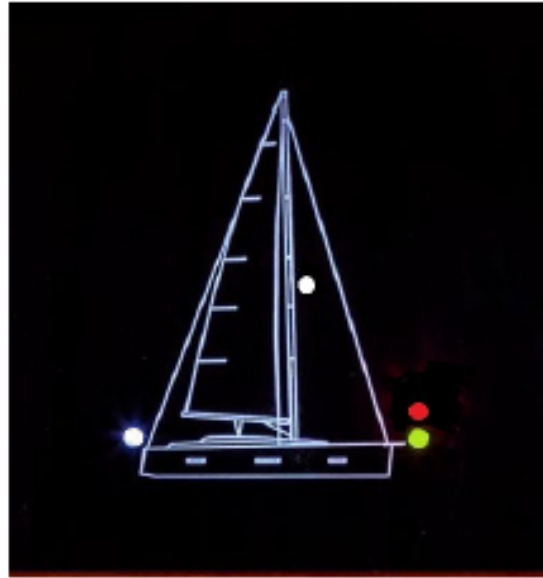

C

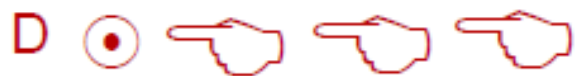

D





NOTES