



DUFOUR
YACHTS

OWNER'S MANUAL



YACHT DESIGN CATEGORY: A

IN ACCORDANCE WITH EUROPEAN DIRECTIVE 94/25/CE
AS AMENDED BY EUROPEAN DIRECTIVE 2003/44/CE

This page intentionally left blank.

This page intentionally left blank.

This page intentionally left blank.

Your agent:

Name

is the **DUFOUR YACHTS'** representative and will give you all the help you need to solve any difficulties you might have during the launching and masting of your boat, as well as for commissioning and maintenance technical checks. If necessary, he will help you with the administrative process of registering your boat.

As soon as you become the owner, familiarize yourself with the manual supplied with your boat, sign and date the receipt acknowledgements below, and give (or send) the last one to your agent.

Acknowledgement of receipt of the Owner's Manual. Owner's copy to be kept in your Manual

I, the undersigned:

Name
Address

owner of **DUFOUR 412** no.

confirm that I have received the **DUFOUR 412** Owner's Manual and accept its being written in the English language.

Dated:

Signature:

Detach along dotted line

✂.....

Owner's Manual receipt acknowledgement to be returned to DUFOUR YACHTS

11, Rue Blaise Pascal- 17187 PERIGNY CEDEX- FRANCE

I, the undersigned:

Name
Address

owner of **DUFOUR 412** no.

confirm that I have received the **DUFOUR 412** Owner's Manual and accept its being written in the English language.

Dated:

Signature:

This page intentionally left blank.

This page intentionally left blank.

This page intentionally left blank.

CONTENTS

INTRODUCTION	7
I. GENERAL INFORMATION	8
YACHT DESIGN CATEGORY: A	8
Certification	8
Identification	8
Builder's plate	9
Degrees of danger	9
II. PRINCIPAL SPECIFICATIONS	10
III. ELECTRICAL SYSTEMS	12
Safety and operating instructions for the electrical system	12
Fitting new equipment	12
Batteries	13
Electric windlass	13
220/110 volt installation (ISO 13297:2000)	14
IV. GAS INSTALLATION	15
Advice for use	15
Controlling the circuit (ISO 10239:2000)	16
Changing gas cylinders	16
V. DRAIN & SANITATION SYSTEM	17
Drainage system characteristics (ISO 15083:2003)	17
Pressurized fresh-water pump	17
Seacocks	18
Operation of the sea toilets	18
Holding tank operation (ISO 8099:2000)	18
VI. FLOODING	19
VII. FIRE PROTECTION	19
Installation	19
Safety instructions	20
VIII. ENGINE	21
General precautions	21
Exhaust gas emission	21
Safety	21
Wintering	22
IX. FUEL INSTALLATION	22
X. HELM SYSTEM	22
Helm	22
Emergency tiller	23
XI. SAILING	23
XII. FALL PREVENTION AND MEANS OF GETTING BACK ABOARD	24
XIII. LIGHTNING PROTECTION	24
Maintenance	24
Protection of people during a thunderstorm	24
XIV. ENVIRONMENTAL PROTECTION & SAFETY	25
XV. SAFETY FACILITIES	26
XVI. HANDLING, TRANSPORTING, HAULOUT	26
XVII. MOORING, ANCHORING, AND TOWING	27
Responsibility	27
Non-metallic anchor points	27
XVIII. GUARANTEE, TRANSFER OF OWNERSHIP	30
XIX. DRAWINGS	33
1. Presentation plan	34
2. Accommodation layout	35

3.	Deck fittings plan	37
4.	Sail plan.....	39
5.	Halyard and sheet operating diagram	41
6.	220V circuit diagram	48
7.	Charging and power system diagram	50
8.	12V electric panel	52
9.	Electrical panel terminal	54
10.	12V electrical installation diagram	56
11.	220V electrical installation diagram.....	58
12-	Fuse location diagram.....	60
13.	Steering system diagram.....	62
14.	Gas system diagram	64
15.	Abandon ship plan	66
16.	Fresh-water system diagram	68
17.	Drain system diagram	70
18.	Skin fitting location diagram.....	72
19.	Mechanical installation diagram.....	74
20.	Holding tank installation diagram.....	76
21.	Lifting diagram	78

INTRODUCTION

DUFOUR YACHTS is pleased to present you with this Manual which will help you get to know your boat better.

This Manual has been produced to help you use your boat safely and enjoyably. It contains details of the boat, the equipment supplied or fitted, its systems and information about their use. Read it carefully and familiarize yourself with the boat before using it.

This Owner's Manual is not a course in sailing safety or seamanship. If this is your first boat or you are changing to a type of boat you are unfamiliar with, for your convenience and safety, make sure you gain experience in handling and using it before taking command. Your agent, national sailing or cruising federation or yacht club will be happy to give you information about sailing schools or qualified instructors in your area.

Ensure that forecast wind and sea conditions correspond to the design category of your boat, and that you and your crew are capable of handling the boat in these conditions. Even when your boat is suitable for them, the sea and wind conditions corresponding to design categories A, B, and C vary from severe storm for category A to severe conditions for the top end of category C, subject to dangers of abnormal gusts or waves; these are dangerous conditions in which only an experienced, trained crew in good shape, sailing a properly-maintained boat, can sail in a satisfactory manner.

This Owner's Manual is not a detailed maintenance or repair guide. In the event of problems, consult the boatbuilder or their representative. If a maintenance manual is provided, be sure to use it.

Always employ the services of an experienced professional for maintenance, fitting accessories, or modifications. Modifications that could affect the characteristics of the boat must be assessed, performed and documented by qualified personnel. The boatbuilder cannot be held responsible for modifications made without their approval.

In certain countries, a skipper's license or some form of authorization is required, or special rules and regulations are applicable.

Always maintain your boat correctly and make allowances for deterioration due to age or resulting, where applicable, from heavy or unsuitable use. Any boat, however sturdy, can be severely damaged if it is used incorrectly. This is incompatible with safe sailing. Always suit your speed and heading to the prevailing sea conditions.

If your boat is equipped with a life-raft, read its instruction manual carefully. The crew must have all the safety equipment on board (life-jackets, harnesses, etc.), corresponding to the type of boat, weather conditions, etc. In some countries, this equipment is mandatory. The crew must be familiar with the use of all the safety equipment and the emergency safety procedures (man overboard recovery, towing, etc.); training sessions are regularly organized by sailing schools and clubs.

It is recommended that all persons wear appropriate buoyancy aids (life-jackets, personal flotation devices) when on deck. It should be noted that in certain countries, it is compulsory to wear a buoyancy aid (complying with national regulations) at all times.

KEEP THIS MANUAL IN A SAFE PLACE AND PASS IT ON TO THE NEW OWNER IF YOU SELL THE BOAT.

WARNING: Our boats are regularly improved in light of our customers' experiences and research carried out by the shipyard. As a result, the specifications given in this Owner's Manual are not contractually binding and may be changed without notice and without any obligation to update them. This manual is intended to cover as much information as possible, so certain equipment or paragraphs might not apply to your boat. In case of doubt, please refer to the inventory which should have been given to you by your agent when you placed your order.

I. GENERAL INFORMATION

YACHT DESIGN CATEGORY: A

Your **DUFOUR 412** comes under the **OCEAN-GOING** design category A.

Under conditions of normal use, your boat is designed to sail in waves with a significant height exceeding 4 m and winds of force 8 or above on the Beaufort scale, and to withstand the severest conditions.

This sailing capability is equally dependent on the skills of the crew, their physical capacities, the maintenance of the boat and its equipment.

So always take care before putting to sea.

DUFOUR YACHTS is not able to guarantee perfect functioning of the boat in exceptional sea conditions (violent storms, hurricanes, cyclones, waterspouts, etc.)

SUMMARY OF DESIGN CATEGORIES

Design Categories	Type of sailing	Wind strength (Beaufort)	Wind speed	Effective wave height to be taken into account
A	Ocean-going	Above 8	Up to 28 m/s	Higher than 4 m
B	Open sea	Up to 8	Up to 21 m/s	Up to and including 4 m
C	Inshore	Up to 6	Up to 17 m/s	Up to and including 2 m
D	Sheltered waters	Up to 4	Up to 13 m/s	Up to and including 0.5 m

Check the weather forecast before putting to sea: **Take to the sea, don't take risks!**

In port: every day, the Harbor Master's Office posts weather bulletins and forecasts for the next few days

Météo France on 08 36 68 08 08

Navifax - direct on 08 36 70 18 52

VHF: CROSS transmits several bulletins per day, preceded by an announcement on Channel 16.

Certification

DUFOUR YACHTS has chosen the Institut pour

Identification

The hull identification number is located on the starboard side of the transom. It contains a series of letters and numbers that begin with FR-DUF...

Builder's plate

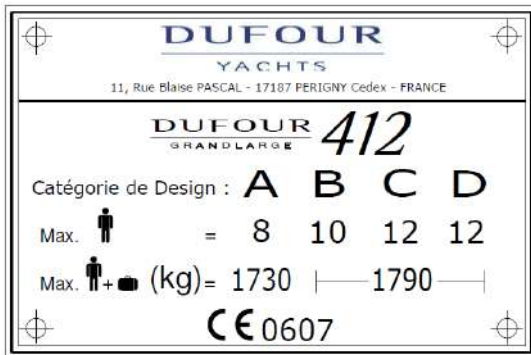

Some of this information is provided on the builder's plate attached to the boat. A full explanation of this information is given below.

Design category = **A**

: Ocean-going (see 1.1)

Maximum number of people:



Category A = **8**
 Category B = **10**
 Category C = **12**
 Category D = **12**

: Recommended by the builder for navigation in sea conditions corresponding to the category for which it was built.

WARNING

Do not exceed the maximum recommended number of people. However many people there are aboard, the total weight of the people and equipment must never exceed the maximum recommended load.

Recommended max. load:



Category A = **1,730 kg**
 Category B = **1,790 kg**
 Category C = **1,790 kg**
 Category D = **1,790 kg**

: recommended by the manufacturer including the weight of all passengers aboard, provisions and personal belongings, in addition to all equipment not included in the boat's light displacement, but excluding the contents of the tanks.

WARNING

When loading the boat, never exceed the recommended maximum load. Always load the boat carefully and distribute the weight in a suitable manner in order to maintain the theoretical trim (approximately horizontal). Avoid placing heavy loads high up.

CE 0607

: CE mark indicating that the boat complies with all the requirements of the Directive. The sequence of digits is the code for the Certifying Body. In this case, it is ICNN (Institut pour la Certification de la Normalisation dans le Nautisme), (see also: Safety Compliance Declaration).

Degrees of danger

DANGER	Indicates an extreme intrinsic risk that presents a high probability of death or permanent injury if proper precautions are not taken.
WARNING	Indicates a risk that presents a high probability of death or permanent injury if proper precautions are not taken.
NOTE	Indicates a reminder about safety-related practices, or points out dangerous practices that could result in personal injury or damage to the boat or its components, or to the environment.

II. PRINCIPAL SPECIFICATIONS

	Model:	DUFOUR 412 Grand Large
	Boatbuilder	Dufour Yachts 11, Rue Blaise Pascal 17187 Périgny cedex FRANCE
	Designer:	Umberto Felci
	Interior design	DUFOUR Design
	YACHT DESIGN CATEGORY: A	A
	Notified body no.	CE/0607
	Engine #	
	Primary means of propulsion	Sail
L_{max}	LOA with/without overhang stemhead*	12.35 m/12.75 m
L_H	Hull length*	11.98 m
B_{max}	Maximum beam*	4.20 m
B_H	Hull beam*	4.20 m
H_A	Maximum air draft*	17.85 m
T_{max}	Draught (deep keel)*	2.10 m
	Deep keel weight	2,600 kg
	Draught (shallow keel)	1.75 m
	Shallow keel ballast weight	2,700 kg
	Standard mainsail area (approximate)	41 m ²
	Genoa area (approximate)	37.5 m ²
	Maximum permissible on-board engine power	55 HP / 41 kW
	Water capacity excl. 20L (appox.) water heater	360 L
	Diesel capacity (approximate)	200 L
	Holding tank	50 L (+45 L as option)
	Engine battery	100 Ah
	Auxiliary battery (1 standard + 1 optional)	100 Ah + (+100 Ah as an optional extra)
	+ 1 with optional electric winch	100 Ah
M_{LC}	Light displacement	8,940 kg
M_{MO}	Minimum condition displacement	9,220 kg
M_L	Maximum loading	2,250 kg
	Total weight of liquids (all tanks full)	526 kg
M_{LDC}	Displacement with maximum load	11,190 kg

*The above dimensions comply with ISO 8866, specifically:

L_{max} : maximum length of the vessel including normally fixed parts such as bow rollers, balconies, etc.

L_H : maximum length of the vessel including structural elements that are an integral part of the vessel, and excluding removable parts.

B_{max} : breadth of the vessel measured between the outermost portions and may include detachable parts such as top rails, railings, etc.

B_H : vessel width measured between the outermost fixed portions and excluding all removable parts

H_A : vertical distance between the water plane in the lightship condition and the highest point of the mast structure. (this does not take into account equipment such as lights and antennas that can be attached to the masthead)

T_{max} : the maximum draft is measured at the lowest points of ballast on board the vessel

M_L : The Maximum Load is the sum of the maximum recommended load plus the total mass of the various liquids (drinkable or not)

Nota bene: due to the trim and loading of the boat, is it not usually possible to use the whole of the various tank capacities for fresh water and diesel. It is recommended that you maintain a diesel reserve of 20%.

Specific information

This vessel has been assessed with the help of the Stability Index (STIX), a measure of overall safety with regard to stability, which takes into account the effects of the length of the vessel, its displacement, hull proportions, stability characteristics and its resistance to flooding.

The maximum total load is the sum of the maximum recommended load and the total mass of the various liquids (see ISO 12217-2: 2002)

The second index (AVS, angle of vanishing stability) represents the heel angle at which stability is lost, in degrees.

	Minimum operating condition (M_{MO})
STIX	43.5
AVS	123.7°

III. ELECTRICAL SYSTEMS

Safety and operating instructions for the electrical system

WARNING

Improper use of the DC and/or AC systems may give rise to fire or explosion hazards.
Improper use of the DC and/or AC systems may give rise to fire or explosion hazards.

Always:

- Check the condition of the batteries (charge and electrolyte level) and the charging system before putting to sea.
- Disconnect and remove batteries for wintering.
- Do not let battery voltage drop below 10.5 V during wintering.
- Carry spare bulbs for all navigation lights and interior lighting. Respect power ratings, particularly for navigation lights.
- Check operation of the navigational instruments.
- Check operation of the navigation lights before sailing at night.

You must never:

- Work on a live electrical installation.
- Make any modification to an installation and the relevant diagrams, unless it is carried out by an electrician qualified in marine electrical work.
- Change or modify the breaking capacity of overload protection devices.
- Replace electrical apparatus or equipment with units exceeding the rated capacity without upgrading wiring and protection.
- Leave the boat unattended when the electrical installation is powered, with the exception of the automatic bilge pump and the fire or theft protection circuits when applicable.

If a fuse or circuit-breaker blows repeatedly, you should consult a specialist to determine the cause of the short-circuit.

Fitting new equipment

Since January 1st 1996, electrical equipment is subject to the European “electromagnetic compatibility” directive (Ref 89/336/CEE). It is therefore necessary that any new equipment you may wish to install meets the requirements of this standard and bears the CE mark. Equipment must also be supplied with a compliance certificate and instructions for use.

In the case of 220 or 110V installations, use only double-insulated or earthed equipment. When such equipment is being installed, respect the fitting instructions (conductor size, protection).

To avoid maintenance problems, make sure that any modifications made to the electrical circuit are recorded in writing in the manual.

Batteries

The battery system is made up of one 100 Ah auxiliary battery (standard) (plus one 100 Ah battery (optional) and one 100 Ah battery with electrical winch option) and one 100 Ah battery for starting the engine.

Their capacities have been designed to handle the power requirements of the on-board accessories. To avoid any problems, it is necessary to keep a close eye on the maintenance and correct charging of the batteries.

ATTENTION!

- When installing new electrical appliances, take care that the total consumption of these appliances remains within the capacity of your batteries.
- Always disconnect the negative (-) battery terminal before the positive (+) terminal.
- Never allow a conductive object (tools, etc.) to bridge across the two battery terminals.
- When handling batteries, keep them horizontal to avoid spillage of electrolyte. Wear gloves and protective clothing that will prevent any risk of contact with the electrolyte in the event of a leak.
- If any electrolyte comes in contact with skin, eyes, etc., rinse the affected part of the body thoroughly and consult a doctor.

Electric windlass

ATTENTION!

You must run the engine with the throttle slightly open when using the electric windlass.

220/110 volt installation (ISO 13297:2000)

DANGER

The on-board 220V installation is protected by a circuit breaker and fitted with a residual current device. The wiring of additional 220V on-board accessories must be carried out by professionals, and the master circuit-breaker updated if necessary.

- Disconnect the boat's power supply when the system is not in use.
- Connect the metal cases or housings of installed electrical equipment to the ship's protective conductor (green or green/yellow wire).
- Use double-insulated or earthed electrical appliances.

ATTENTION!

When the boat is moored at the quayside, set the isolator to the 'off' position.

DANGER

Your boat is not supplied with a shore/boat supply cable or a male plug for the shore outlet. The cable must be suitable for outdoor use. Its cross-sectional area must be adjusted according to its length and the rating of the main circuit-breaker (see electrical diagram). The plug must be suitable for the socket on the shore (if necessary, seek professional advice). It should be as close as possible to the **IP 67/IEC529 type**

- Switch off the shore supply at the on-board isolator before connecting or disconnecting the shore/boat supply cable.
- Connect the shore/boat supply cable at the boat end before connecting it to the shore outlet.
- Disconnect the shore/boat supply cable at the shore outlet before disconnecting it at the boat end.
- Close the shore outlet cover properly.

You must never:

- Make any modifications to the shore supply cable: use only compatible connectors.
- Go swimming close to a boat connected to a shore supply socket: danger of electrocution!

Location of the 220 V master circuit-breaker: Aft technical area (access through port aft cabin)

Have the system checked every 2 years.

During haul-out maintenance, set to the 'on' position in order to have **earth [grounding] protection** via the shore socket.

WARNING

Never let the end of a ship/shore supply cable dangle into the water. It may create an electrical field that could injure or kill nearby swimmers.

IV. GAS INSTALLATION

Advice for use

- Carefully read the cooker and gas regulator manuals before use or maintenance.
- Ensure that the gas cylinder and regulator are in accordance with the requirements of the cooker (flow rate, pressure, type of gas) and with the regulations in force in the country where it is being used.
- Make sure all the appliance valves are closed before opening the gas cylinder valve.

WARNING

- Fuel-burning naked-flame appliances use up the oxygen in the cabin and release combustion products inside the vessel. Proper ventilation is necessary: Open both the deck hatch or porthole located nearby and the companionway when the appliances are in operation.
- Never obstruct the exhaust vents. Check that the appliances are equipped with flue pipes which work correctly.
- Do not use the cooker/oven as a heating appliance.

- Do not obstruct quick access to the elements of the gas installation (cylinder locker, shut-off valve).
- Gas cylinders must always be stored in the designated ventilated and watertight housing. The same applies to reserve and empty cylinders. Make sure store protection devices, caps or covers remain in place. No other equipment should be stored in this compartment.
- Never leave the vessel unattended when gas appliances are on.
- Close all circuit valves when the boat is unoccupied (shut-off valve, gas regulator valve), even when you think that the cylinder is empty. In this case, disconnect the valves.
- After the boat has been shut up, never smoke when going below, and ensure that there is no smell of gas.
- If you smell gas, close all the circuit and cooker valves, ventilate the boat, and locate the leak before using the installation.

WARNING

The circuit valves should be shut off immediately in case of emergency (fire).

ATTENTION!

Certain precautions must be taken to avoid any contact with naked flames or other hot areas. Never use the cooker when significant roll or heeling angles are likely (in the absence of a gimbal-mounted cooker).

Controlling the circuit (ISO 10239:2000)

The LPG installation should be inspected for leakage before each use.
Check the seal of all connections in the following manner:

- close all appliance valves
- open the cylinder valve
- allow the manometric pressure to stabilize
- shut off the cylinder valve
- observe the pressure gauge value for 3 minutes; if it decreases, there is a leak and the appliances should not be used
- locate leaks with a detection device or by applying soapy water (cylinder valve open, all others closed) or any other foaming solution which complies with the EN14291 standard
- repair the leaks before reusing the installation; it is recommended that repairs or modifications to the circuit are carried out by a qualified professional.

ATTENTION!

Do not use ammonium solutions.

DANGER

Never use a flame to look for leaks.

Flexible hoses should be:

- regularly inspected, at least once a year,
- replaced according to the expiry date printed on the hose,
- replaced within five years of the manufacture date that may be printed on the hose,
- replaced in the case of deterioration.

Changing gas cylinders

DANGER

- Shut off all cooker valves as well as the circuit valve upstream of the cooker before changing the cylinder.
- Refrain from smoking or using a naked flame while LPG cylinders are being changed.
- Ventilate the gas cylinder compartment well when changing the gas cylinder.

WARNING

In case of an LPG installation:

- never leave the vessel unattended when gas appliances are on.
- refrain from smoking or using a naked flame while LPG cylinders are being changed.
- close the valve on the empty cylinder before disconnecting it to change.

V. DRAIN & SANITATION SYSTEM

Drainage system characteristics (ISO 15083:2003)

Pump type	Theoretical flow rate
Manual	38 L @ 45 strokes/minute
12V Electrical	1,800 L/h

Read the operating and maintenance instructions for your boat's bilge pump carefully.

WARNING

The bilge pump system is not designed to handle water entering as a result of holing of the hull. It is intended to remove water coming from spray, leaks from seacocks or other moderate leaks.

ATTENTION!

- The level of water in the bilge must be kept to a minimum.
- Make sure that bilge pumps are in working order before putting to sea.
- Regularly remove any debris that might obstruct the sump well and the pump intake points or strainers.

If the watertight bulkheads that isolate the fore- and after-peaks are fitted with valves, they should normally be kept closed and should only be opened to drain the water into the main bilge.

- Know where to find each hand pump and its handle
- Locate the switch for the electric bilge pump on the electrical panel.

Pressurized fresh-water pump

Fresh water is supplied to the sink and washbasins by an electric pump. A filter is installed upstream of the pump, and must be cleaned regularly.

Never allow the pump to run if the tank is empty. Refill the tank before using the water supply again.

The tanks can be sterilized using Clonazone® tablets (available from pharmacies). Every year, remove the inspection covers and clean them by filling with water containing a bactericidal detergent; leave it to act for a few hours, then rinse two or three times. During wintering, completely fill the tanks to avoid the development of algae or bacteria. If there is a risk of freezing, empty the tanks; never use anti-freeze.

Hot water is produced by a water-heater connected to the engine cooling circuit and the shore electric supply.

After the water-heater has been emptied, make sure that the element is covered before power is re-applied.

Seacocks

Seacocks are of the ¼-turn type:

- OPEN position: handle in line with seacock body,
- CLOSED position: handle perpendicular to the seacock body.

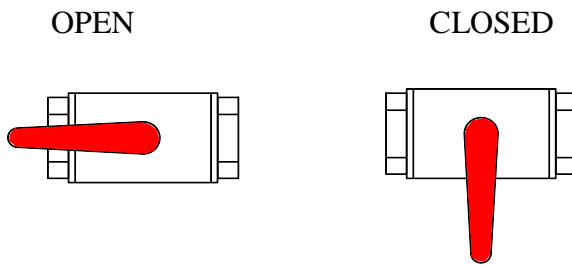

ATTENTION!

- Never interfere with the tightening of the seacocks to the hull. In the event of a leak, consult a professional.
- In bad weather or when leaving your boat, close all the sanitation system seacocks.
- Keep seacocks closed when not in use.
- During wintering, clean and rinse the seacocks and skin-fittings. Inspect brass fittings; slight surface corrosion is normal.
- In the event of more serious corrosion, consult your agent.

Operation of the sea toilets

- Open the sea water inlet cock.
 - Open the bowl emptying seacock.
 - Set the lever to the "FLUSH" position.
 - Operate the pump.
 - To empty the bowl and avoid any water slopping when heeling, set the lever to the "DRY BOWL" position.
 - Operate the pump until the bowl is dry.
 - Repeat these flushing/emptying operations as many times as is necessary to ensure complete emptying of the pipes.
- When toilets are not being used, set the lever to the "DRY BOWL" position, or the "CLEF" position for certain models.
- **Close seacocks after use, as the toilet is below the waterline.**
 - Change the toilet seals regularly.

Holding tank operation (ISO 8099:2000)

ATTENTION!

Where a holding tank is fitted, take care to lock the discharge valve, to avoid any accidental discharge during wintering.

- The sewage tank operates using the manual toilet pump.
 - The contents of the toilet pan are discharged straight into the holding tank.
 - Periodically check that the vent is working properly.
 - A deck plate is provided for emptying the tank.
 - The discharge valve can be sealed in the closed position using a padlock.
 - Once a season, arrange to clean out the tank using a biodegradable disinfectant chemical.
- Leave the system empty if the vessel is to be left in below-freezing temperatures

VI. FLOODING

To avoid the risk of flooding the boat:

- Check that portholes, deck hatches, and any other openings that may cause flooding, are closed before putting to sea.
- While under way, close all seacocks when they are not in use, except for the engine water intake.
- Do not exceed the maximum recommended loading.
- The level of water in the bilges must be kept to a minimum.
- Avoid adding weight in high places so as not to affect the stability.

Periodically check:

- Skin fittings, seacocks and pipes are watertight.
- Proper emptying of the cockpit drains.
- Stern glands or sail-drive seals for watertightness.

WARNING

Cockpit locker lids must be fastened shut before putting to sea. This is particularly important for those lockers that represent a major flooding risk.

VII. FIRE PROTECTION

Installation

Since fire extinguishers are subject to national regulations, they are not supplied with the boat.

However, when in use, this boat must be fitted with portable extinguishers with the following capacities, installed in the following locations (see drawing in Appendix):

- No. 1 – cockpit locker, within reach of the helmsman - capacity 1 kg - 5A34B
- No. 2 – galley unit - extinguishing capacity 1 kg - 5A34B
- No. 3 – saloon/mast foot - extinguishing capacity 1 kg - 5A34B

If you decide to install a carbon dioxide (CO₂) extinguisher, be aware that it may only be fitted in accommodation areas that contain powered electrical equipment (e.g. electric motors, battery compartments, electrical panels) or flammable liquids (e.g. galley).

Only compatible replacement parts must be used in the fire protection system. They must bear the same markings and be technically equivalent.

In addition, a fire blanket should be stored in the saloon banquette, close to the galley. This can be very useful, particularly in the event of an oil-based pan fire: saloon banquette.

If non-combustible materials are stored in the engine compartment, they must be secured to avoid the risk of falling onto the machinery and must not obstruct access to the engine compartment or its exit.

WARNING

If a CO₂ extinguisher is fitted, the following information must be displayed close to its location:

“This extinguisher contains CO₂ - use only on electrical or cooker fires. To avoid suffocation after discharging, leave the area immediately. Ventilate before re-entering.”

Do not open the engine compartment immediately after putting out a fire to avoid the release of toxic smoke or spraying of burning materials (oil, water)."

Safety instructions

ATTENTION!

It is the responsibility of the owner/skipper to:

- Have fire-fighting equipment checked in accordance with the stipulations of the builder and the regulations in your country.
- Replace fire-fighting equipment if it has expired or been discharged, with extinguishers of equal or greater capacity.
- Show members of the crew:
 - The location and operation of fire-fighting equipment
 - the location of the engine compartment discharge hole
- Ensure that fire-fighting equipment is readily accessible whenever the boat is occupied.
- Always keep the bilges clean and check that there is no fuel vapor or gas leak.
- Point out the escape routes.

You must never:

- Obstruct gangways leading to emergency exits (deck hatches).
- Obstruct safety controls (gas valves, fuel valves, electrical switches).
- Obstruct fire extinguisher stowages.
- Leave the boat unattended with a cooker or heater on.
- Use a gas lamp in the boat.
- Fill a fuel tank or change a gas cylinder while the engine is running, or the cooker or heater are on.
- Smoke while handling fuel or gas.
- Place free-hanging curtains near the cooker or any other appliance which has an open flame.
- Store flammable substances in the engine compartment.
- Modify, or allow any non-qualified person to modify, any of the boat's installations (especially electrical, fuel, or gas).

VIII. ENGINE

Regular maintenance must be carried out in accordance with the engine manufacturer's recommendations. Read the engine operating instructions that come with the boat carefully. Do not hesitate to consult your agent or a qualified professional. In particular, follow the instructions for wintering.

General precautions

ATTENTION!

Do not use the sail and engine if the heel angle is more than 10°.

Any engine change must respect the capacities of the boat and be performed by an engineer specializing in marine mechanics.

After the first launching and tensioning of rigging, check the alignment of the propeller shaft or the sail-drive flange ring.

- Make sure that the ventilation openings (vents, engine air intake grating) are completely clear.
- Make sure that the water intake seacock for the cooling system is open, and that water is indeed coming out of the engine exhaust.
- Boats fitted with a rotating seal stern gland: bleed the air from the gland after each launch.

Put the throttle in neutral before starting the engine to keep the boat from moving and/or the propeller from turning.

On subsequent launches, a brief check of propeller fixing can be made. Incorrect operation of the folding propeller will lead to vibration.

Regularly check the condition of the anodes and ensure that they are suitable for the boat's environment (fresh water, salt water). Change the anodes every year. The 3 anodes have an average life of 1–2 years.

These anodes are made of zinc. You must not use magnesium ones. Impressed current cathodic protection systems should not be used.

If the anodes are not eroded, you need to check:

- that they have not been painted over,
- that they are correctly fixed and in contact with the hull,
- and that they are indeed made of zinc

Exhaust gas emission

DANGER!

Internal combustion engines produce carbon monoxide. Prolonged exposure to exhaust gases can have serious consequences, and may even cause death.

Safety

DANGER!

In order to avoid all risk of serious injury from the propeller, the engine must not be started when there are people swimming near the boat.

Whenever possible, the engine must be stopped for any engine maintenance or checking operations. Otherwise, special attention must be paid to moving parts (propeller shafts, belts, etc.) in order to avoid any risk of injury.

Wintering

Read the operating and maintenance instructions for the engine that goes with your boat and the instructions for wintering carefully.

In the absence of other instructions, proceed as follows:

- Close the engine water intake seacock,
- Disconnect the pipe from the engine water intake seacock,
- Drain the sea-water circuit,
- Place the pipe into a drum of -25° anti-freeze coolant,
- Run the engine until the fluid comes out of the exhaust,
- At the end of this operation, re-connect the pipe to the seacock,
- Attach a notice to the electrical panel and the battery isolator stating that the engine water intake seacock is closed.

IX. FUEL INSTALLATION

In the event of deterioration, flexible fuel pipes must be replaced by pipes bearing the same markings. Do the same for all fuel lines.

ATTENTION!

- Depending on the trim and loading of your boat, not all of the nominal fuel capacity may be used. Always maintain a 20% reserve for safety.
- Avoid contact between flammable materials and hot parts of the engine.
- Clean up any overflow of fuel that may occur when filling the tanks.

You must never:

- Store flammable materials in unventilated spaces.
- Smoke while filling tanks.
- Obstruct ventilation openings (vents, engine air intake grating): Make sure they are completely clear.
- Modify the installation, unless work is done by a qualified technician.

X. HELM SYSTEM

The steering system plays a vital role in the safety and comfort of your boat.

Helm

The **DUFOUR 412** is fitted with a dual wheel with a system of rudder cables and chains as well as with an emergency tiller.

Checks to be carried out periodically: Check the play in the various elements (rudder stock/bearings, tension and wear in mechanical components) and grease the sprocket and chain if necessary.

In the event of any doubt or problem, consult your agent.

Emergency tiller

ATTENTION!

- The **Dufour 412** is fitted with an emergency tiller which must be kept readily accessible; we advise stowing it in one of the nacelle cockpit lockers.
- It is designed only for sailing at reduced speed in the event of damage to the helm.

To use it:

- Unscrew the deck-plate to reveal the head of the rudder stock
- Fit the tiller onto the head of the rudder stock.

XI. SAILING

WARNING

In all situations, adapt the speed of your boat to the surrounding conditions and always maintain a safety margin. Pay particular attention to:

- Sea conditions, currents and the strength of the wind
- Movement of other boats
- Manoeuvres in port
- When passing through mooring areas
- Obey the rules of right of way as set out in the Rules of the Road as established by COLREG
- Ensure that you always have enough room for stopping or for any necessary manoeuvres to avoid a collision
- Respect speed limits
- Out of courtesy and for the safety of other boats, exercise care and attention to minimise your boat's wake near other boats
- Movable items must be carefully secured when at sea

WARNING

- You must fit your boat with grab lines. Anchor-points are provided on the deck. Please refer to the deck fittings plan for your boat.
- The stability of your boat has been designed taking into account the boat's weight specification for light displacement, the standard equipment on board and the manufacturer's catalogue options.

Any alteration to on-board weight distribution (for example: adding a radar, changing the engine, etc.) can affect the stability, trim and performance of your boat.

Breaking waves represent a significant threat to stability.

Towing another boat produces significant extra loading, which will have an adverse effect on the stability of your boat.

- **You must never:**
Lift heavy weights using the boom.

XII. FALL PREVENTION AND MEANS OF GETTING BACK ABOARD

While underway, it is recommended to move about on deck only in areas provided for this purpose. These areas (gangways, cockpit, roof, side seats, etc.) are provided with non-skid coatings or teak (depending on option selected) making it safe to move about.

Depending on sea conditions, wind and the degree of heel, it is also recommended that you use the harness by attaching it to the various attachment points mentioned in the deck fittings plan.

The **DUFOUR 412** is equipped with a swim ladder built into the stern door. In this case, lower the stern door by releasing the retrieval cord. Then disengage the ladder from its housing and unfold it into position.

A safety ladder is also provided in case of emergency. It is located on the starboard stern rail, and can be deployed from the water.



XIII. LIGHTNING PROTECTION

Your boat is protected against lightning. The rigging is electrically earthed (grounded). Nonetheless, for your safety, it is necessary to respect certain precautions.

Maintenance

If the vessel has been hit by lightning:

- The protection installation must be inspected to detect physical damage and check the integrity of the device, as well as the continuity of the earthing.

- The compasses, electrical and electronic devices must be examined in order to ascertain if damage or calibration changes have occurred.

Protection of people during a thunderstorm

WARNING

During a thunderstorm, it is recommended that you comply with the following instructions:

- People should stay below as much as possible.
- People should stay out of the water and not let their arms or legs hang into the water.
- While maintaining satisfactory control of the vessel and its course, persons aboard should not touch any parts connected to a lightning protection system, and especially not in such a way as to form a link between these parts.
- People should avoid touching any metallic parts of the rigging, spars, deck fittings and life-lines.

XIV. ENVIRONMENTAL PROTECTION & SAFETY

We recommend that you find out about local regulations concerning the environment and obey international regulations against pollution in the marine environment (MARPOL), together with the codes of good practice.

Do not discharge the toilets or the contents of the holding tanks near coasts or in prohibited areas; use port or marina pumping systems for emptying the holding tanks before leaving port.

ATTENTION!

- Most cleaning products, engine oils and fuels are likely to impact the environment, so they should be discharged in authorized locations (check with the Harbor Master's office).
- Do not run the bilge pump when oil or fuel is present in the engine compartment, as these chemicals must be discharged in authorized locations.
- Certain products can also pose a risk to your safety and that of others, which is why it is important to read and follow the instructions for use.
- Chemicals must be labelled and stored in an appropriate place on the boat.

XV. SAFETY FACILITIES

There is no harmonization of mandatory safety equipment across the European Community. You should find out about current national requirements for CE-marked vessels.

In France, the skipper is responsible for ensuring that recreational craft bearing the CE mark carry the mandatory handling and safety equipment stipulated for the relevant sailing category.

Your boat is provided with a stowage position for a life-raft; read the life-raft instruction manual carefully. The crew should be familiar with the use of all safety equipment (harnesses, flare, life-raft, etc...). Training sessions are organized regularly by sailing schools and clubs.

XVI. HANDLING, TRANSPORTING, HAULOUT

When craning, take care that the slings are correctly positioned and are not fouling the propeller, the sail-drive or a fragile transducer.

Lifting frames must be wide enough, or fitted with spreaders, so as to avoid applying excessive lateral pressure on the rubbing strakes.

Avoid allowing slings to foul the life-lines. During transport or haulout, the keel should be in proper contact with its support and should be taking most of the boat's weight.

Cradle pads must be positioned against structural elements in order to exert only the pressure necessary for the boat to be properly balanced.

Take advantage of the opportunity provided by haul-outs to inspect the propeller, rudder, skin fittings, and transducers.

ATTENTION!

The aft lifting point is located near the propeller.

XVII. MOORING, ANCHORING, AND TOWING

ATTENTION! (ISO 15084:2003)

The boat builder must provide information regarding the breaking strain of anchor points.

- In general, the breaking strain of lines/chains must not exceed 80% of the breaking strain of the anchor points.
- If the use of a specific anchor point is not apparent, the boat builder must provide both a label on the anchor point (anchor points for mooring and/or towing) and information in the owner's manual.
- Tow or be towed at a low speed. Never exceed the hull speed of a displacement boat in tow.
- The tow line should always be made fast in such a way that it can be released when under load.

Responsibility

It is the owner/operator's responsibility to ensure that the mooring lines, towing cables, anchor chains and lines, together with the anchors, are suitable for the boat's intended use, i.e. that the lines or chains do not exceed 80% of the breaking strain of the corresponding anchor point.

Furthermore, the owner must take into account the actions required when making fast a tow cable.

Non-metallic anchor points

If non-metallic anchor points are installed on the boat, the owner must take into account their limited lifetime. They should be replaced whenever they show signs of wear, visible surface cracks, or permanent twisting.

Note that black elements are less sensitive to UV-rays than light-colored ones.

Sea and River Charter

***Water is a living and fragile environment.
It is also a valuable resource.***

To protect this environment:

- Respect the sea and rivers; do not enter protected sites, limit fishing to authorized species and sizes and observe wildlife without touching or disturbing it.
- Before anchoring, find out about the nature of the seabed to avoid damaging it. Use mooring buoys whenever possible.
- Dispose of household waste in the corresponding containers, and dispose of toxic, solid and liquid waste using harbor waste facilities.
- Use port sanitary facilities. Drain holding tanks using port pumpout facilities. Use the most environmentally-friendly detergents.
- Ensure that any maintenance operations (boat and equipment) are carried out with respect to the environment. Handle all potentially polluting liquids carefully.





At the service of boaters and maritime professionals

Lifeboat crews keep watch...

All sailors know that the sea cannot be taken lightly. Despite considerable progress made by boat builders in terms of safety, it is nevertheless possible that one day you will depend on lifeboats and crews due to an incident at sea.

Round the clock, every day of the year. 3,500 volunteers are ready to put to sea within 30 minutes to assist to those in difficulty... sometimes at the risk of their own lives!

Thanks to a very tight network of 255 stations in France and its overseas territories, the "Sauveteurs en Mer" (Sea Rescuers) are responsible for nearly 50% of sea rescues in France today

At sea; you may need them, on land they need you...

The rescue of human lives is free but the methods used are expensive. The Sauveteurs en Mer, more and more of whom are recruited from recreational boaters, need your help to maintain, modernize and replace their nautical equipment (1 all-weather lifeboat costs €700.000!)

Please support or even join this generous, discreet and efficient body of men and women. Contact the station manager at your nearest home port or contact our headquarters in Paris.



BETWEEN SAILORS...



- Before putting out to sea, inform a trusted person of your intentions
- find out about local weather conditions (weather, current, etc.)
- use reliable VHF radio equipment and inspect it regularly
- ensure that children wear life jackets at all times

HUMAN LIFE IS PRICELESS

BUT A LIFEBOAT HAS A COST!



LES SAUVETEURS EN MER (S.N.S.M.)

Head office: 31 cité d'Antin 75009 PARIS

tel. : +33(0)156 026 464 - Fax +33(0)156 026 463 - E-mail: www.snsn.com.fr

I support the SNSM!

I enclose a cheque for €20 min.

€45

(donor) - 380 €

(benefactor)

You will receive a tax deductibility receipt with a member's card and sticker

NAME: FIRST NAME:

ADDRESS:

Telephone: E-mail:

XVIII. GUARANTEE, TRANSFER OF OWNERSHIP

A) CONTRACTUAL GUARANTEES

Note: This guarantee does not apply to boats being used for commercial purposes (it being specified that any hiring or chartering activity falls into this category) nor to sailing boats taking part in competitions, which may be covered by special guarantees.

8 - Guarantees

a) New boats and equipment:

8.1.1 – For both Commercial Purchasers and private consumers domiciled outside the territory of the European Union, the Seller grants the statutory warranties as defined in the context of the sale of vessels by Articles 1641 and 1648 of the French Civil Code and in the context of a marine construction contract by Articles 7 and 8 of Law no.. 67.5 dated 3rd January 1967 pertaining to vessels.

8.1.2 – For Purchasers domiciled within the territory of the European Union and taking out the contract as private consumers, the Seller is required to furnish the guarantees as defined in the context of a boat sales contract by Articles 7 and 8 of the Act dated 07/01/1967 pertaining to vessels, and in the context of the Order (2005-136) dated 17/02/2005 and incorporated into the French Consumer Code. Independently of this guarantee, the Seller remains liable for discrepancies between the goods and the contract and for redhibitory defects under the conditions provided for under Articles 1641 to 1649 of the French Civil Code (see. 8.1.1).

8.2 – Visible defects: acceptance by the Purchaser releases the Seller from their obligation in respect of discrepancies and visible defects.

8.3 - Contractual guarantee:

Except for guarantee or penalty clauses expressly agreed at the time of accepting the order, the Seller's guarantee is granted under the following conditions:

- The Purchaser benefits from a contractual guarantee running for two years from the date of acceptance of the vessel, as noted on the acceptance report.
- This is limited to the replacement or free repair, at the yacht-builder's discretion, of any parts acknowledged as being defective by the yacht-builder's technical services; this being without any other compensation of any kind.
- For components and accessories visibly bearing the mark of another supplier, the guarantee is limited to the guarantee offered by that supplier.

- It is stipulated that any handling, transport, parking, or conveying costs incurred in carrying out these operations remain the sole liability of the buyer/user, unless **DUFOUR YACHTS** yacht-builders offer to waive them in full or in part.
- The boat-builder's warranty excludes:
 - the cost of transporting the boat or any parts, and any consequences thereof, together with expenses and/or any damage arising out of the inability to use the boat and/or the equipment;
 - normal wear and tear;
 - cracking, crazing, or discolouration of the gelcoat;
 - damaging resulting from:
 - fortuitous events or cases of force majeure;
 - conversions and modifications, or repairs, even partial, carried out other than in workshops authorized by the maker;
 - failure to observe the maintenance recommendations set out in the Owner's Manual supplied with the boat;
 - improper use, in particular through negligence, carelessness, abuse, or abnormal usage;
 - participating in competitions;
 - failure to take necessary protective measures;
 - unsuitable storage or transport conditions.

In order to benefit from the yacht-builder's contractual guarantee, each time they make a claim under it, the buyer/user will be required to submit the boat delivery certificate and the guarantee document, duly completed, and, on pain of rendering it void, must notify their dealer/vendor of the fault or defect in writing, in detail and with justifications, within 15 days of its being discovered.

8.4 – the guarantee covers usage at sea in wind and sea conditions acceptable for safety and in accordance with the vessel's approval category. Under these conditions, it cannot under any circumstances cover events arising during or resulting from collisions, groundings, breaking seas, tidal waves, cyclones, severe storms, and all other exceptional events and/or events arising out of an error of seamanship.

8.5 – Loss of or damage to products occurring after handover do not release the Purchaser from their obligation to pay the price.

b) Second-hand boats and equipment:

The order form specifies if the boat or equipment is second-hand. The Purchaser benefits from a contractual guarantee, covering hull and engine only, running for one year from the date of acceptance of the vessel or goods, as noted on the acceptance report.

c) In addition to the contractual guarantee detailed above, the Seller remains liable for discrepancies in the goods and for latent defects under the conditions provided for under Articles 1641 to 1649 of the French Civil Code and the provisions of the Order dated 17/2/2005, where applicable.

B) COMMON GUARANTEE CONDITIONS

Any claim under these guarantee conditions must be made formally to **DUFOUR YACHTS** in writing as soon as the defect is discovered, and within eight (8) days for claims under the contractual guarantee. Any claim will also be required to quote the serial number of the boat concerned, and where applicable the part number(s) of the part(s) involved in the guarantee claim.

Furthermore, the request must indicate the exact circumstances under which the problem occurred.

In order to investigate the request, DUFOUR YACHTS may ask for any details and appoint, at its own expense, a surveyor or technician of its choice to determine the circumstances of the occurrence of the problem and demand any necessary papers.

Immobilization following problems encountered and/or replacement and/or repair work, whatever the duration, does not create entitlement to compensation.

The owner shall under all circumstances remain liable for parking fees, customs dues and other ancillary expenses.

All repairs and/or replacements will be carried out by an authorized **DUFOUR YACHTS** agent or by a professional duly acting under the Boatbuilder's instructions. If the nature of the repairs requires the guarantee repair work to be carried out in **DUFOUR YACHTS** workshops or in any location other than the place where the Product is located, the owner will be liable for the cost of both outward and return transport to the Yacht builder.

In the event that the boat needs to be taken out of the water, haul-out and re-launching costs will be at the owner's expense.

C) TRANSFER OF GUARANTEES

The guarantees are afforded to the first purchaser of the boat involved. They are only transferable with **DUFOUR YACHTS'** prior written agreement.

An ownership transfer note is supplied with the Product documents. This must be sent to **DUFOUR YACHTS** within thirty (30) days of the transfer.

This note must bear the names, addresses and telephone numbers of the old owner and the Purchaser, the date of sale, and the Product's hull number.

Upon reception, **DUFOUR YACHTS** will confirm the guarantee expiry dates and specify whether the unit has received the annual inspection that gives entitlement to the continuation of the contractual guarantees.

D) STATUTORY DECLARATIONS

Article L.211-4 of the Consumer Code:

"The seller is required to supply goods that conform to the contract and to assume liability for discrepancies existing at the moment of handover. He shall likewise be liable for discrepancies arising out of the packaging, assembly instructions, or installation when he is liable for this under the contract or it has been carried out under his responsibility."

Article L. 211-5 of the Consumer Code:

"In order to conform to the contract, the goods must:

1) Be suitable for the normal expected use for similar types of goods and, where applicable:

- correspond to the description given by the seller and possess the qualities the latter has presented to the buyer in the form of a sample or model;

- present the qualities that a buyer may reasonably expect with regard to public declarations made by the seller, by the producer or by his representative, particularly in advertising material or labelling;

2) Either present the characteristics defined by joint agreement between the parties, or be suitable for any special usage sought by the buyer that the seller has been made aware of and has agreed to."

Article L.211-12 of the Consumer Code:

"Actions arising out of a discrepancy lapse after two years from the date the goods are handed over."

Article 1641 of the Civil Code:

"The seller is obliged to guarantee against latent defects in the article sold which render it unfit for its intended use, or which adversely affect this use to such an extent that the buyer would not have purchased it, or would have only paid a lower price, if he had known about them."

Article 1648, Para. 1 of the Civil Code:

"Actions arising out of redhibitory defects must be brought by the purchaser within two years of discovery of the defect."



DUFOUR

YACHTS

TRANSFER OF OWNERSHIP CERTIFICATE TRANSFER OF OWNERSHIP

Boat model:

Hull no.:

From Mr. Ms: Address:

ZIP/POST CODE: City: Tel:.....

Date of Purchase:

BEING SOLD TO:

Mr/Ms: Address:

ZIP/POST CODE: City: Tel:.....

Date of Purchase:

Signed at date

Seller

Buyer

Signed for DUFOUR YACHTS on: ..

Return the copy within 15 days of completing the transaction to

SAV DUFOUR YACHTS
11 rue Blaise Pascal
17187 PERIGNY CEDEX FRANCE

XIX. DRAWINGS

1.	Presentation plan	34
2.	Accommodation layout.....	35
3.	Deck fittings plan	37
4.	Sail plan	39
5.	Halyard and sheet operating diagram	41
6.	220V circuit diagram	48
7.	Charging and power system diagram	50
8.	12V electric panel	52
9.	Electrical panel terminal	54
10.	12V electrical installation diagram	56
11.	220V electrical installation diagram	58
12-	Fuse location diagram	60
13.	Steering system diagram	62
14.	Gas system diagram	64
15.	Abandon ship plan	66
16.	Fresh-water system diagram	68
17.	Drain system diagram	70
18.	Skin fitting location diagram	72
19.	Mechanical installation diagram	74
20.	Holding tank installation diagram	76
21.	Lifting diagram	78

1. Presentation plan

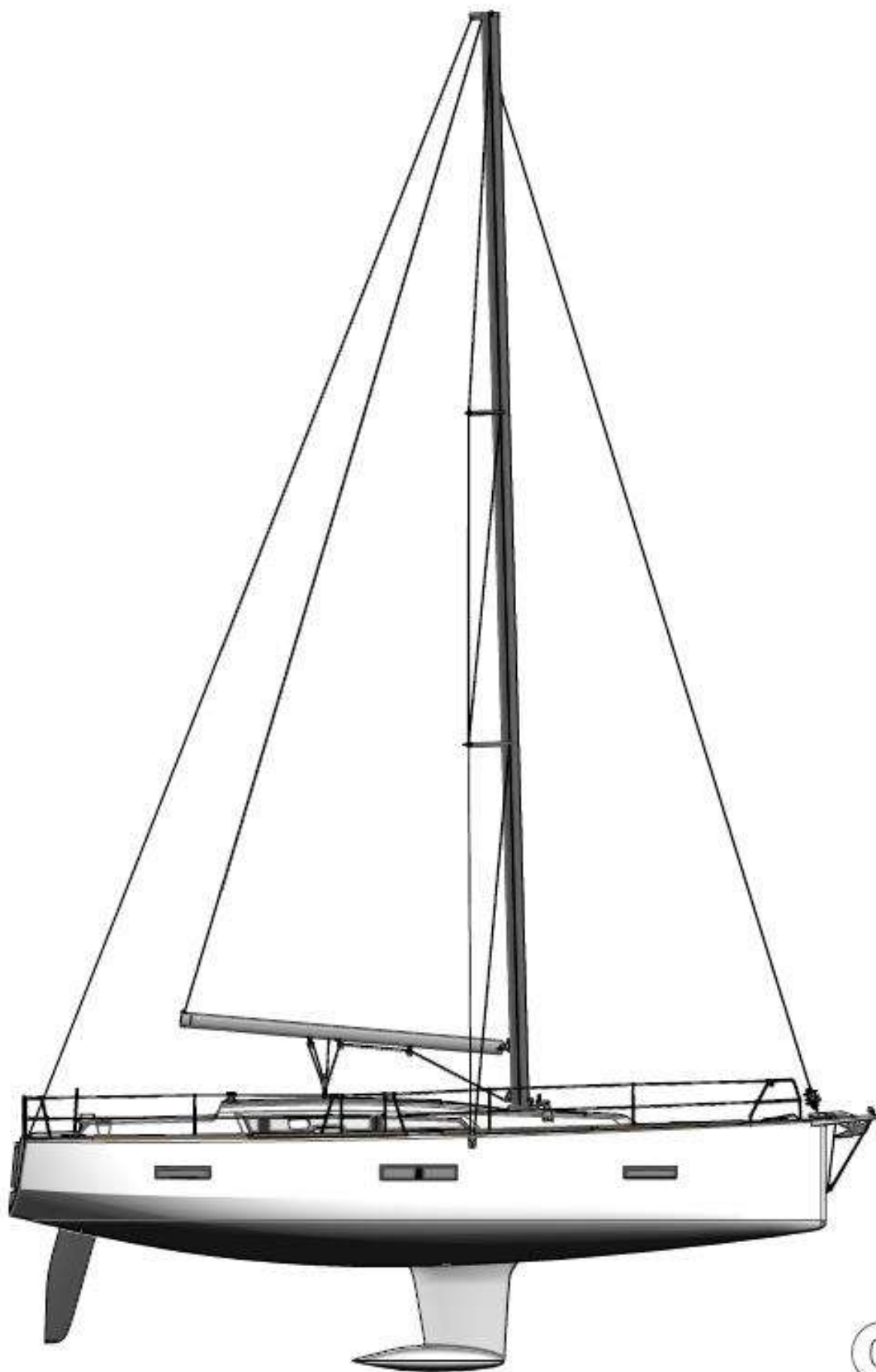

01

2. Accommodation layout

<i>Description</i>
<i>A - 3-cabin version - 1 Bathroom</i>
<i>B - 2-cabin option</i>
<i>C - Optional extra bathroom</i>

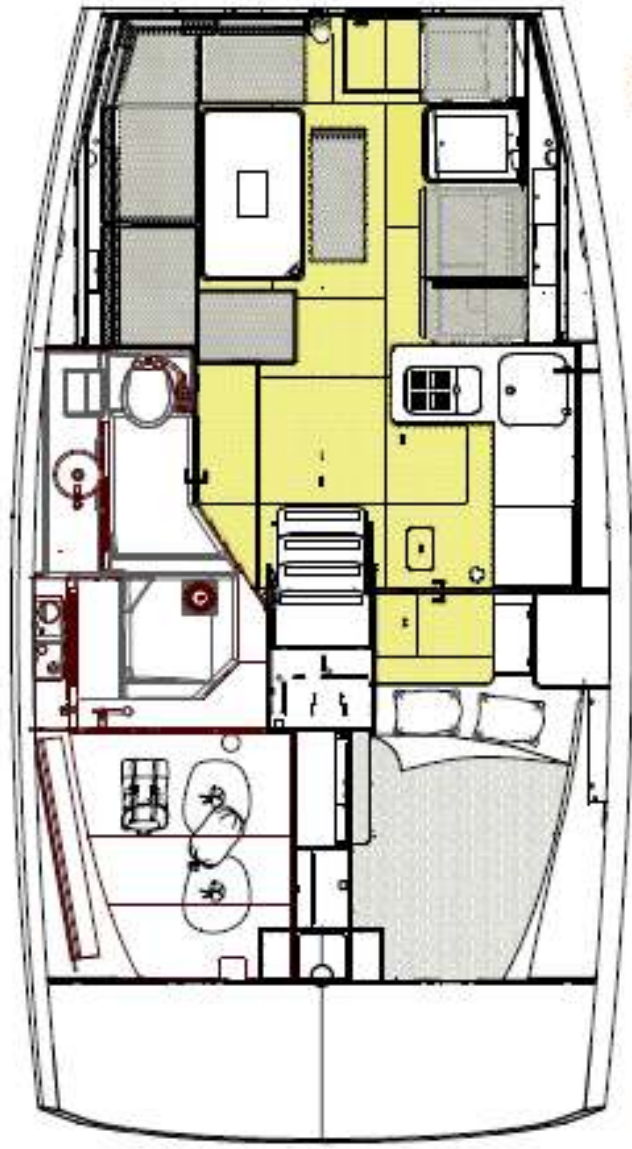
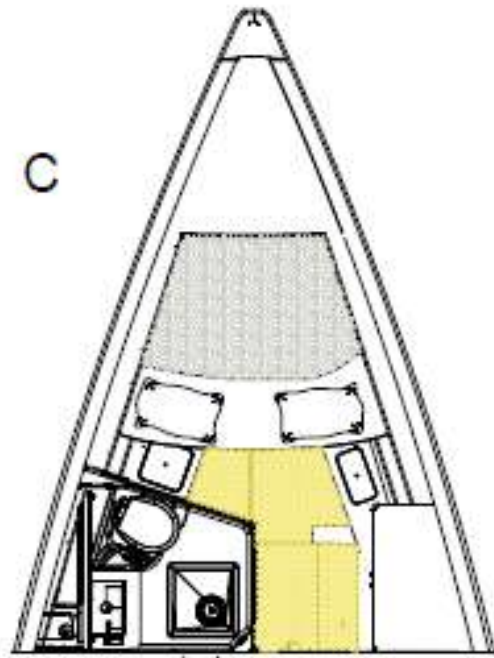
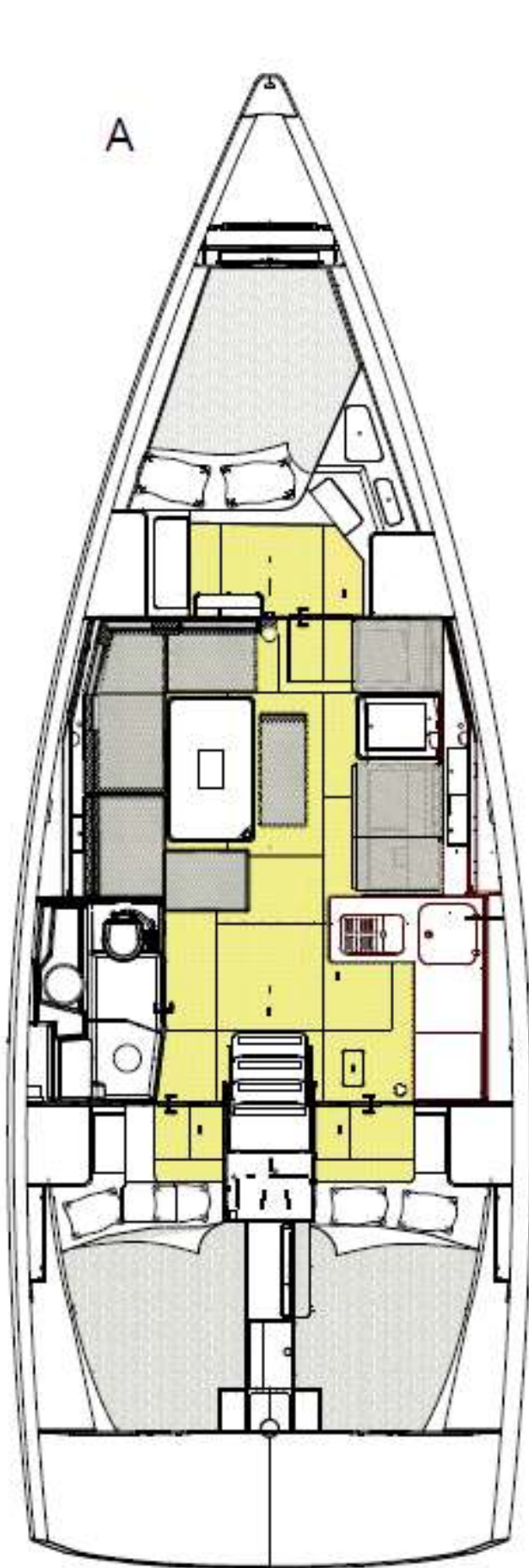

B

02

3. Deck fittings plan

Label	Description
1	Bowsprit bow roller
2	Self-tacking jib sheet
3	Mooring cleats
4	Stanchions
5	Stanchion bases
6	Toe rail
7	Gate stanchions*
8	Genoa track and traveller
9	5-sheave deck organizer
10	Mainsail track and traveller
11	Coachroof clutches
12	Halyard winches
13	Genoa sheet turning block
14	Sheet winches
15	Mainsheet clutches*
16	Pulpit
17	Pushpit
18	Shroud chainplates
19	U-bend
20	Spinnaker folding pad eyes*
21	Genoa furling line clutch
22	Spinnaker tack line clutch*
23	Coachroof handrail
24	Horseshoe buoy bracket
25	Folding bathing ladder
26	Safety ladder
A	Jackline anchor points Port & starboard cleats
B	Port & starboard towing points (Bd & TD)
C	Hatches must be closed when underway
D	"MAN OVERBOARD" REBOARDING LADDER
E	Life raft stowage
F	Anchor point for safety harness
G	Lockers must be closed when underway
H	Tender stowage location
*	Option

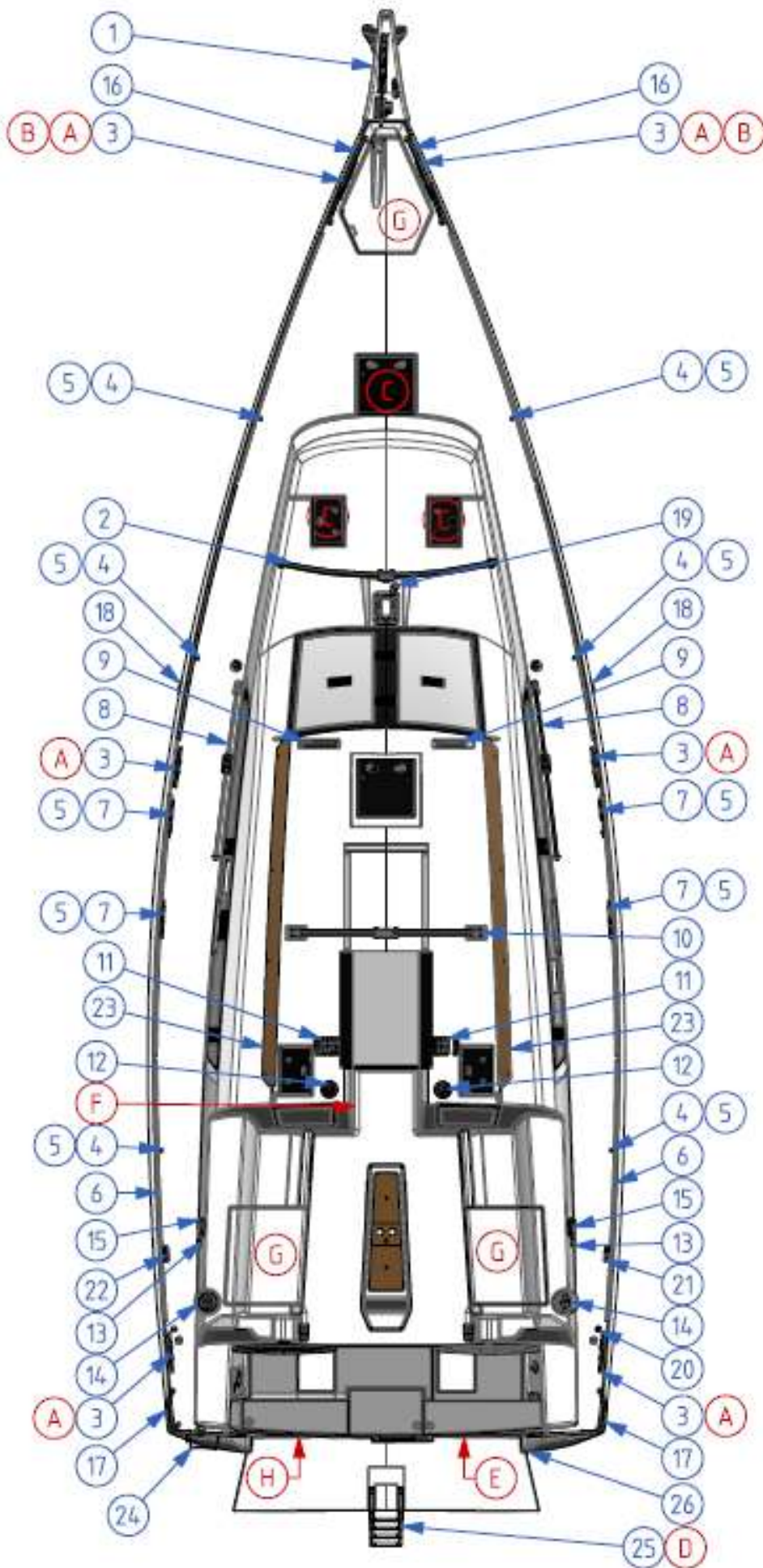

03

4. Sail plan

	Standard mast	Grand Prix mast
I	14.50 m	15.10 m
J	4.30 m	4.30 m
P	13.92 m	14.72 m
E	4.70 m	4.70 m
LP (128% overlap)	4.61 m	4.61 m
Mainsail area	38 m ²	41 m ²
Genoa area (128%)	35.6 m ²	37.5 m ²
Asymmetric spinnaker area*	xx m ²	
* Option		

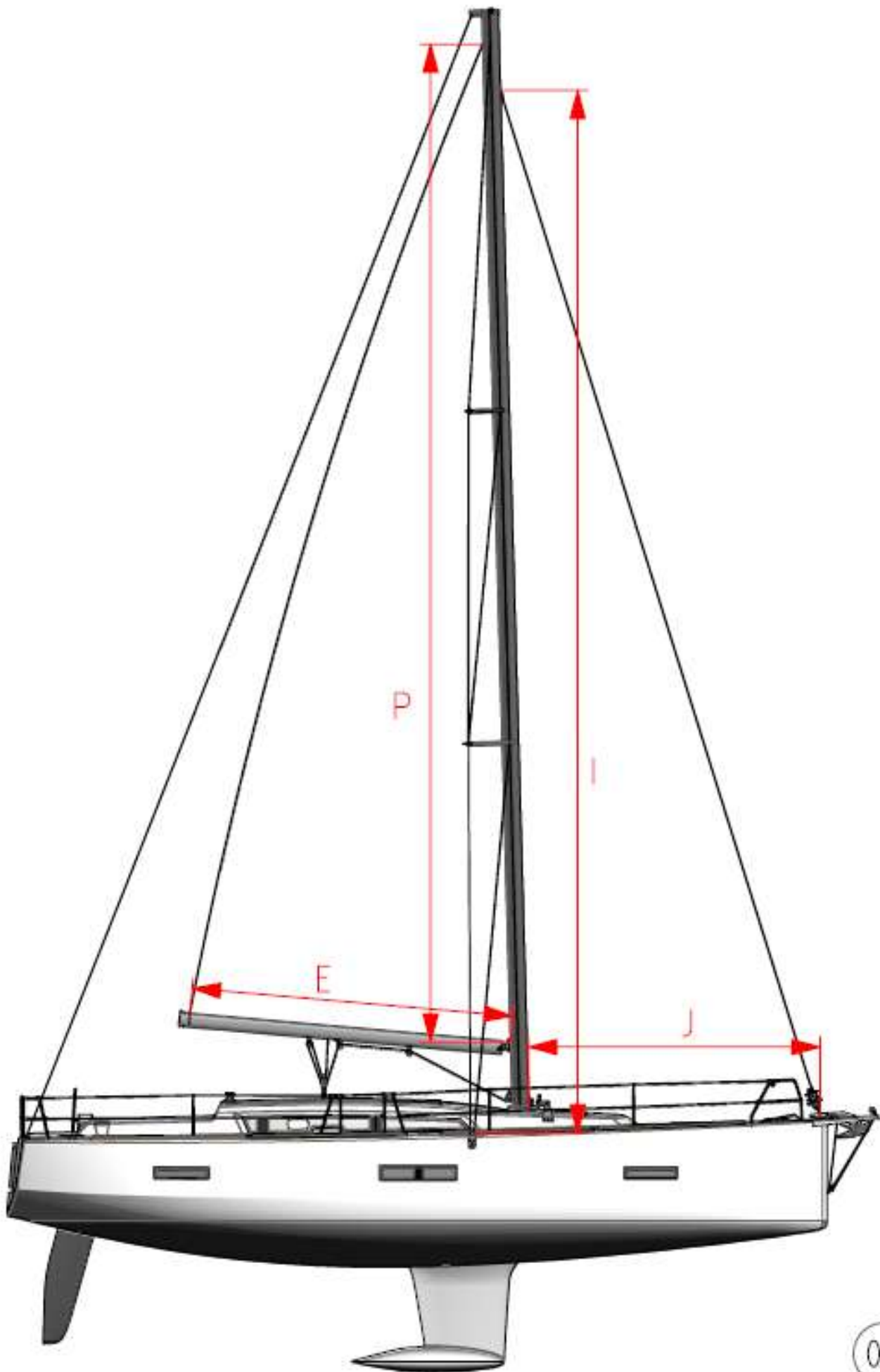

04

5. Halyard and sheet operating diagram

<i>Label</i>	<i>Description standard mast</i>
1	Mainsail traveller trim
2	Removable inner forestay halyard or self-tacking jib*
3	Genoa halyard
4	Reef 2
5	Mainsail foot
6	Boom vang
a	Standard mainsheet
b	German System mainsheet*
8	Reef 1
9	Mainsail halyard
10	Spinnaker halyard*
11	Spinnaker sheet*
12	Genoa sheet
13	Genoa traveller adjustment*
14	Spinnaker tack*
15	Genoa furling line
16	Bobstay*
*	Option

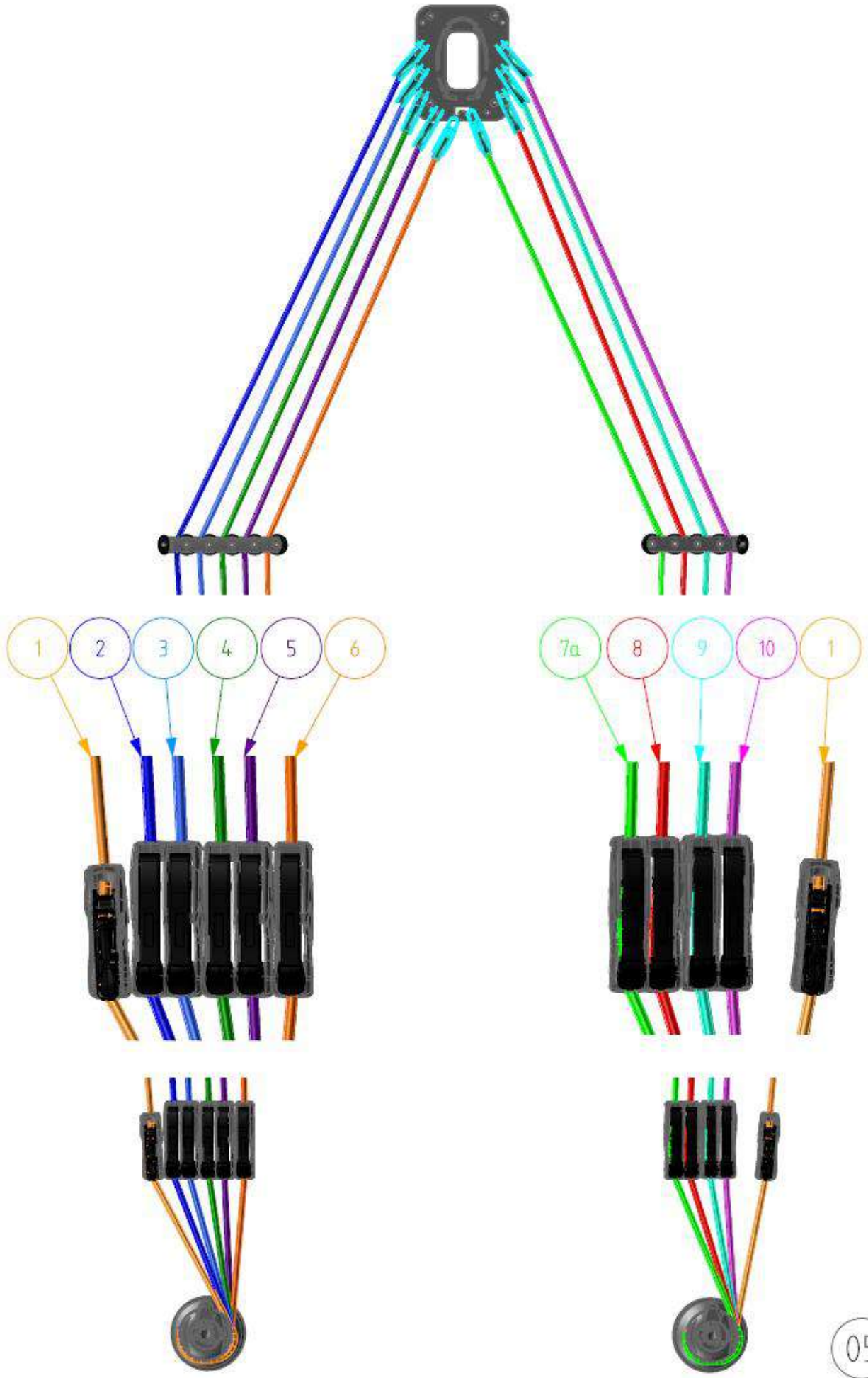

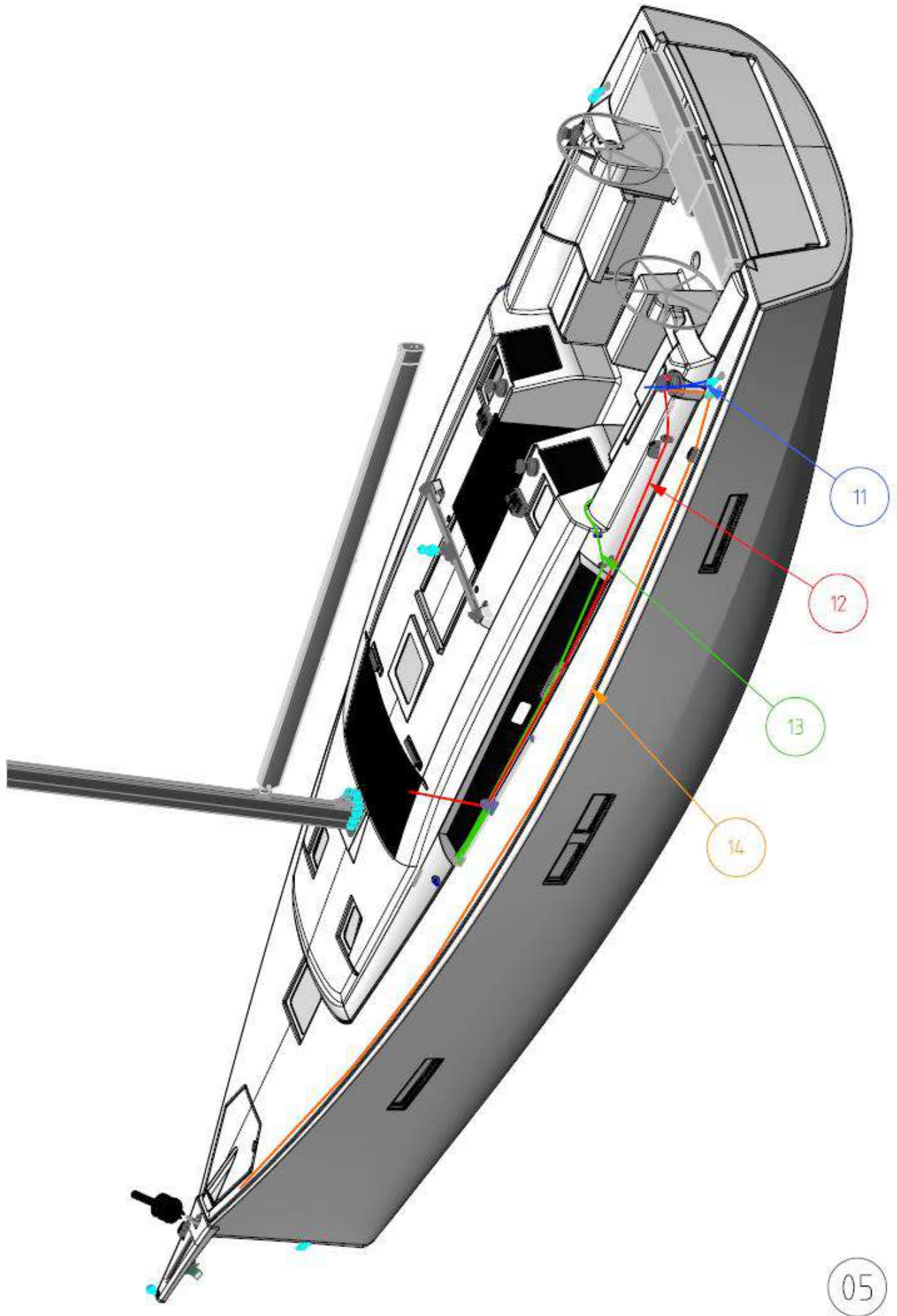

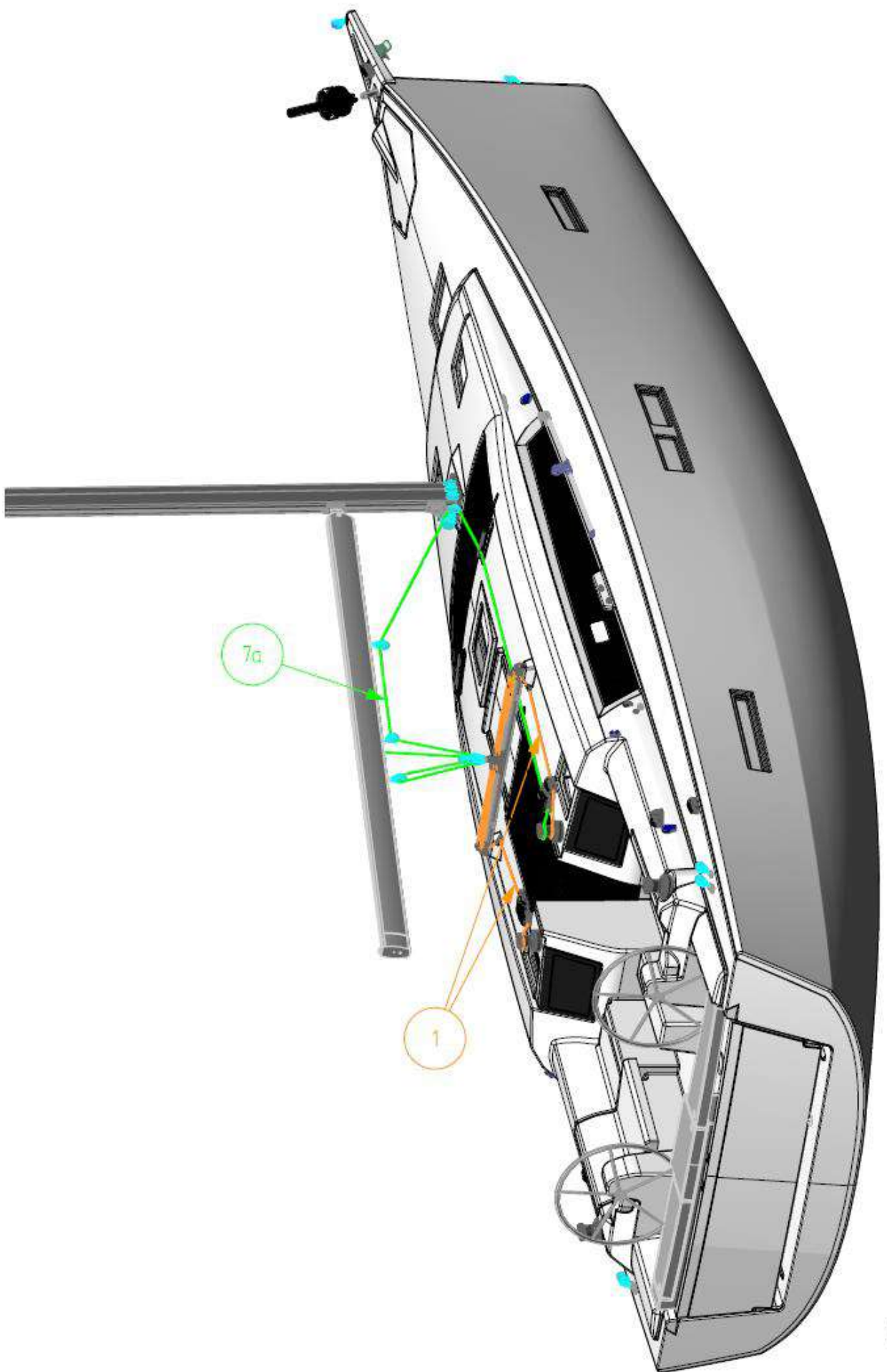

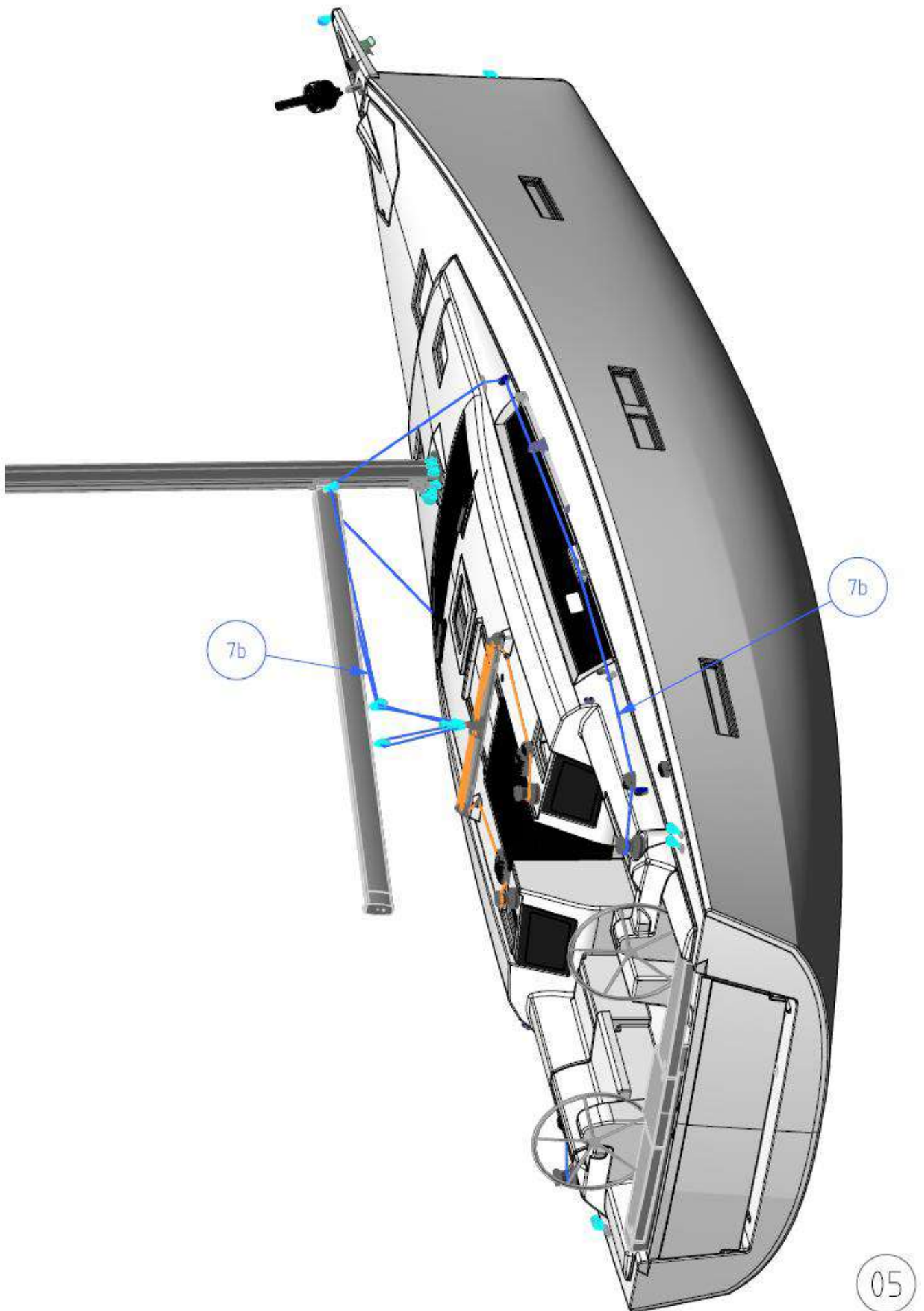

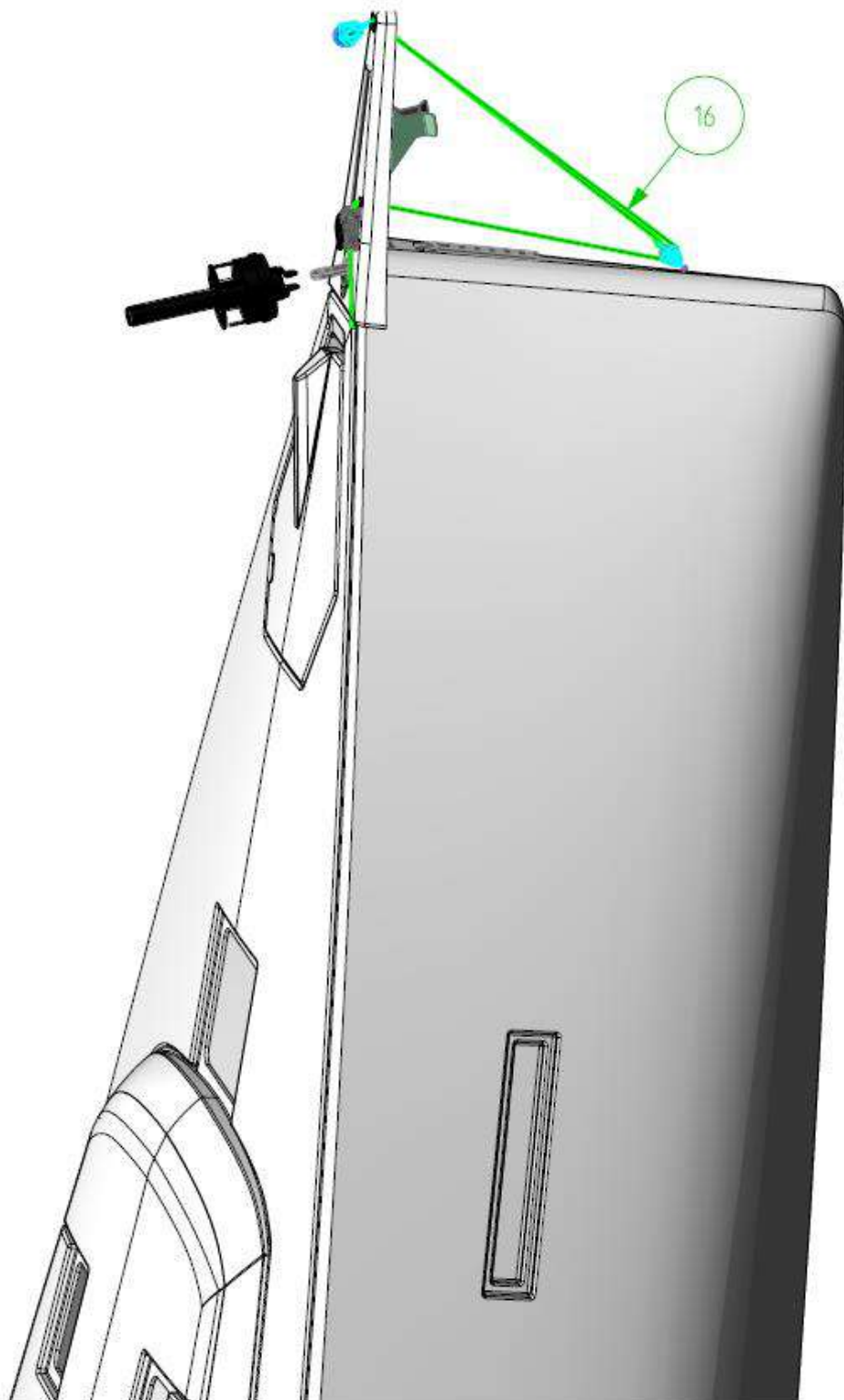

05

6. 220V circuit diagram

Label	Description
Facilities	
A	220V Shore cable**
B	Shore AC connection
C	16A Electrical box with main circuit breaker
D	Charger
E	CE waterproof plug connection
F	Water heater
G	220V 10A outlets
H	220V microwave oven*
I	Connector (back panel of electrical cabinet)
J	12-way connector
Electrical wiring colours	
<i>b</i>	light blue
<i>g</i>	green
<i>m</i>	brown
<i>n</i>	black
<i>r</i>	red
<i>v</i>	green/yellow
<i>w</i>	white
*	Option
**	Not supplied

7. Charging and power system diagram

<i>Label</i>	<i>Description</i>
A	Windlass*
B	Windlass remote control*
C	Remote control relay*
D	8A fuse: engine test
E	Charger*
F	12V distribution panel
G	Single-pole 110A circuit breaker*
H	Auxiliary batteries (1 as std + 2 as option*)
I	125A fuse (auxiliary)
J	House batteries switch
K	5A fuse*
680 l	Alternator
M	Distributor
N	Starter
O	Engine battery
P	Engine battery isolator
Q	Windlass relay*
R	Bilge fan relay
S	5A fuse
T	Bilge fan
B-	-ve terminal (electrical panel)
B+	+ve terminal (electrical panel)
*	Option

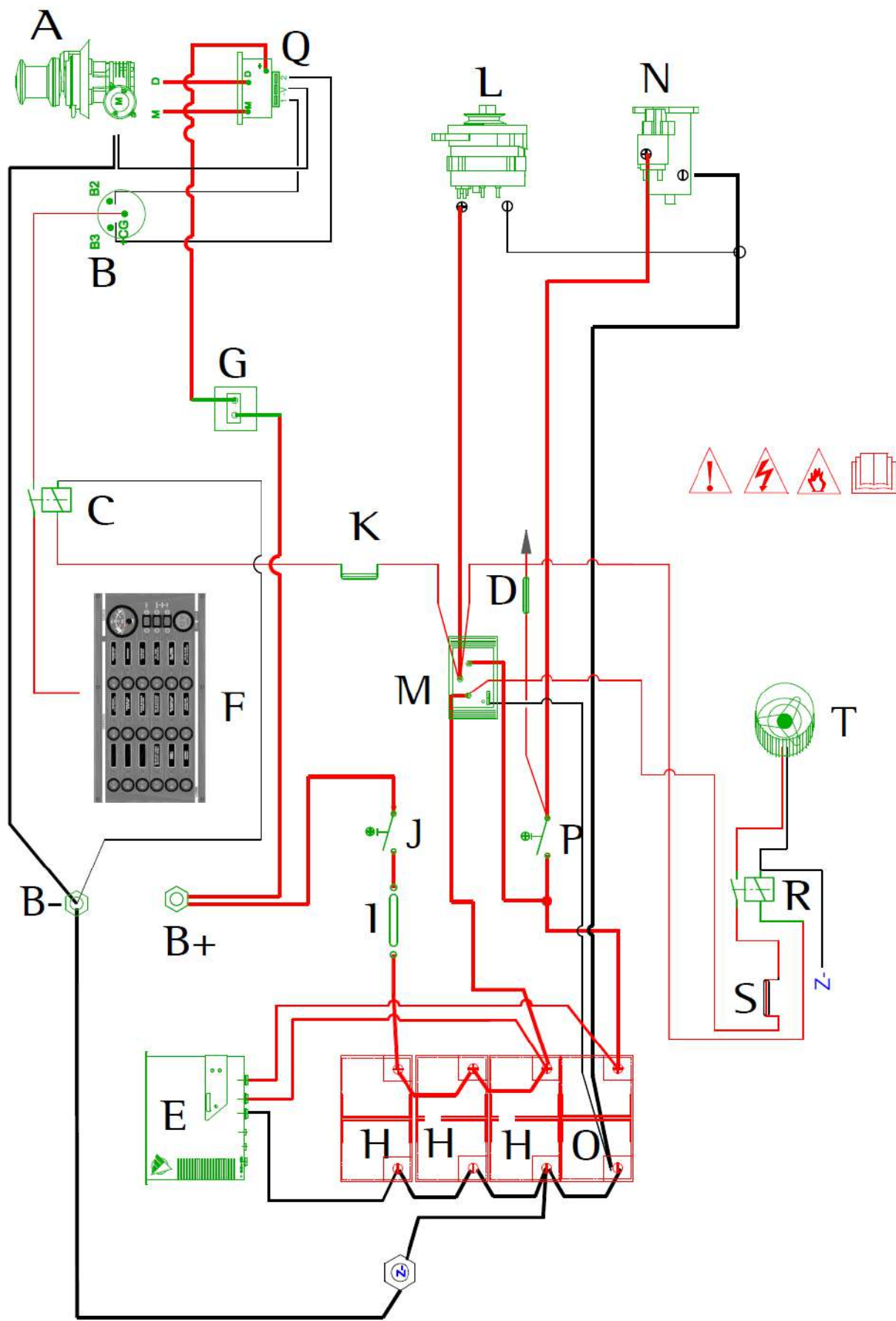

8. 12V electric panel

<i>Label</i>	<i>Description</i>	<i>Protection</i>
	12V distribution panel	
1	Miscellaneous 3	
2	Miscellaneous 4	
3	Miscellaneous 5	
4	Deck light	A
5	Miscellaneous 2	A
6	Windlass control	A
7	Pressurized water system	A
8	Bilge pump	A
9	Shower pumps	A
10	Navigation lights	A
11	Mooring light	A
12	Steaming light	A
13	Fridge unit	A
14	Navigation instrument pack	A
15	Auto pilot	A
16	Saloon lights	A
17	Cabin lighting	A
18	HIFI* / 12V outlet	A
19	Voltmeter	
20	Fresh-water gauge	
21	Fuel gauge	
22	12V outlet	A

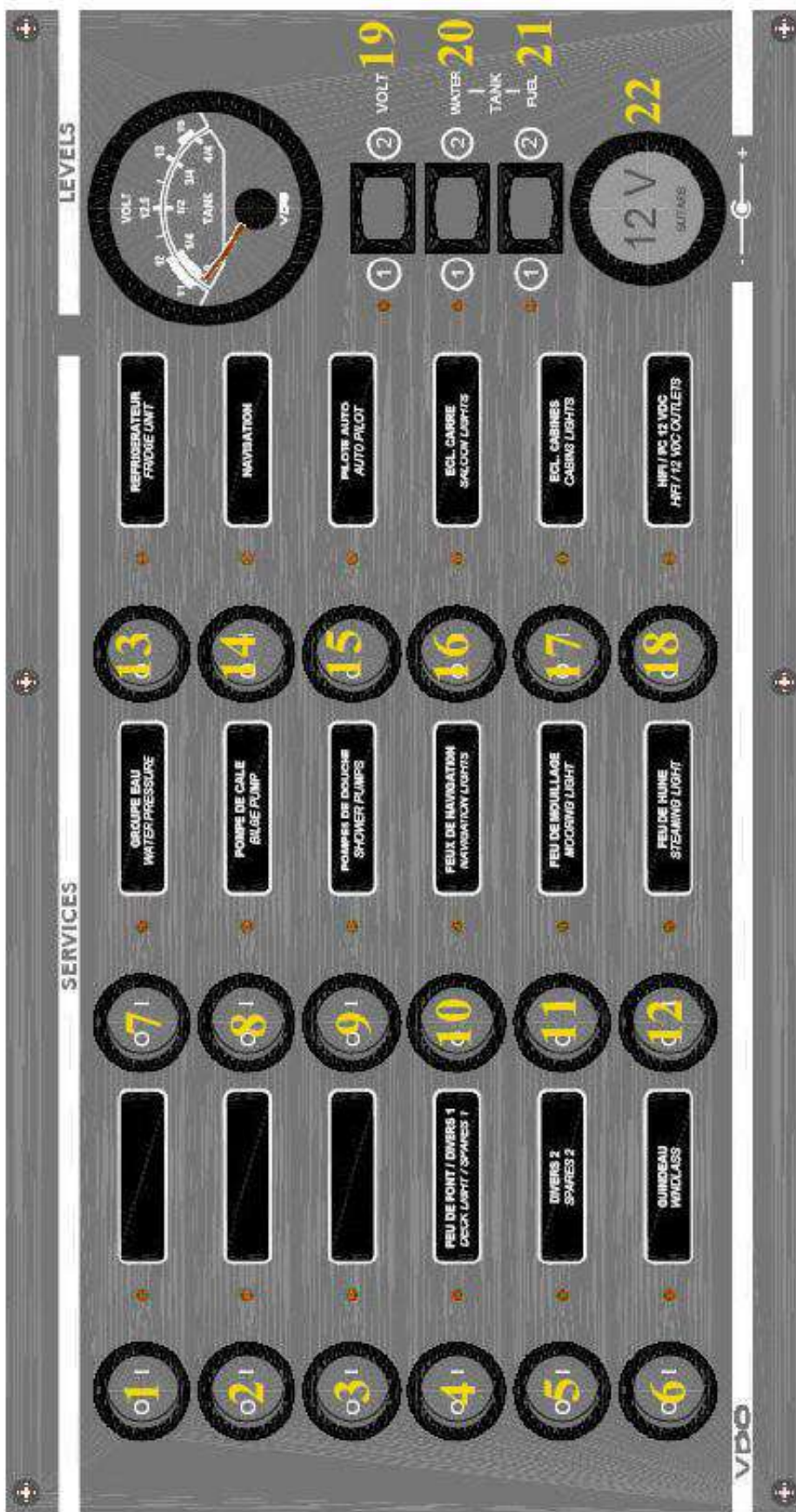

9. Electrical panel terminal

<i>Label</i>	<i>Description</i>
A	A Connector
1	Pressurized water system
2/5	Battery positive
3	Fridge unit
4	Bilge pump
6	Navigation equipment**
7	Shower drain pump
8	Battery negative
9	Autopilot engine
B	B connector
1	Navigation lights
2/5	Battery positive
3	Saloon/chart table lights
4	Mooring light
6	Cabin and toilet lights
7	Steaming light
8	Battery negative
9	HIFI* / 12V outlet
C	C Connector
6	Engine battery test
1/2/3/4	Aft watertank sensor – D2
9/10/11/12	Fore watertank sensor – D1
5	Fuel gauge sensor - G1
7/8	Negative
D	D Connector
1	Deck lights
2/5	Battery positive
3	Spares 5
4	Spares 2
6	Spares 4
7	Windlass control
8	Battery negative
9	Spares 3
	<i>Electrical wiring colours</i>
<i>n</i>	black
<i>r</i>	red
<i>w</i>	white
<i>o</i>	orange
<i>m</i>	brown
<i>b</i>	blue
*	Option
**	Not supplied

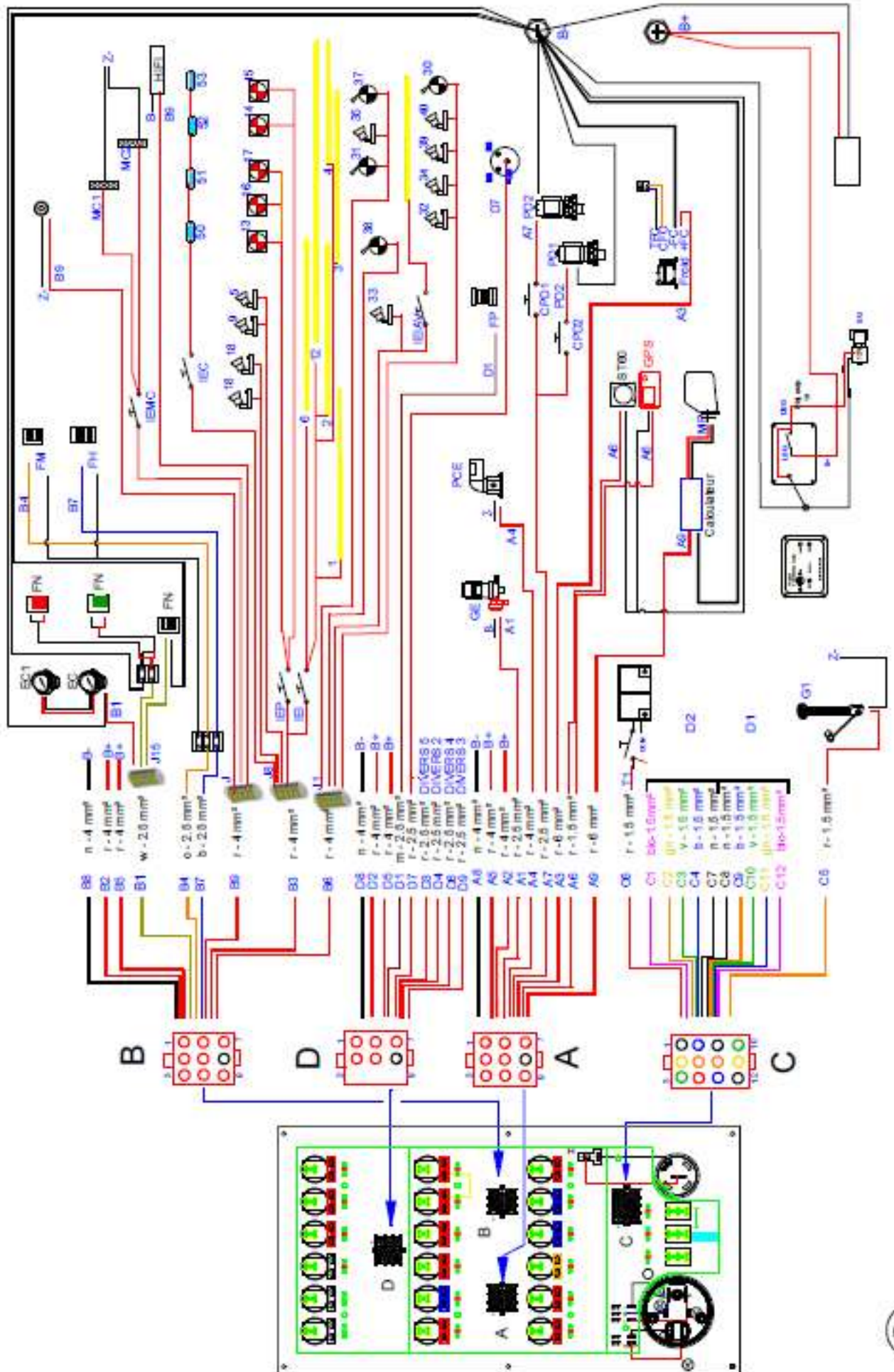

10. 12V electrical installation diagram

<i>Label.</i>	<i>Description</i>
1	Windlass*
2	Windlass relay*
3	Windlass remote control*
4	Navigation lights (on pulpit)
5	Chromed reading light
6	Fresh-water gauge
7	Depth/speed transducer*
8	Courtesy light
9	Round ceiling light & switch
10	Steaming light
11	Deck light
12	Mooring light
13	Electric bilge pump
14	Saloon speaker
15	Indirect lighting
16	12V electric panel
17	Refrigeration unit
18	Round ceiling light without switch
19	Switch
20	Water pump unit
21	Shower waste pump
22	Outdoor handrail light
23	Bathroom downlight with switch
24	Alternator
25	Starter
26	Engine battery 100 Ah
27	Auxiliary batteries 100 Ah (1+ 2*)
28	Engine and auxiliary battery isolator
29	Motor fan
30	Fuel gauge
31	Service fuse
32	Cockpit table reading light
33	Steering compass
34	Cockpit speaker
35	Autopilot motor*
36	Navigation lights
37	Fresh-water gauge
38	Charge splitter
*	Option

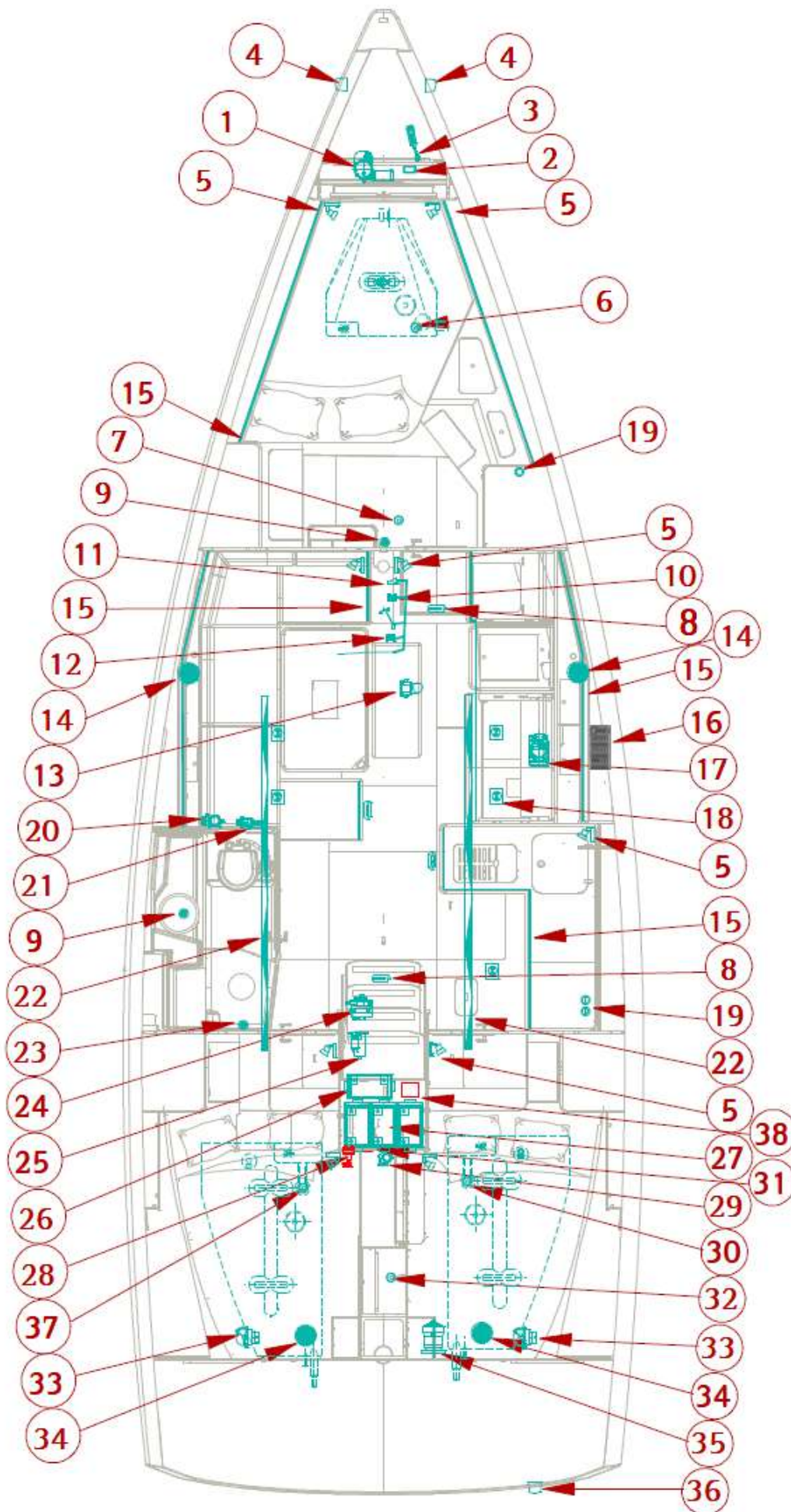

11. 220V electrical installation diagram

<i>Label</i>	<i>Description</i>
1	220V (or 110V) outlet*
2	Water heater
3	Battery charger
4	Main circuit-breaker box
5	G Connector
6	Shore AC connection
7	Microwave outlet*
*	Option

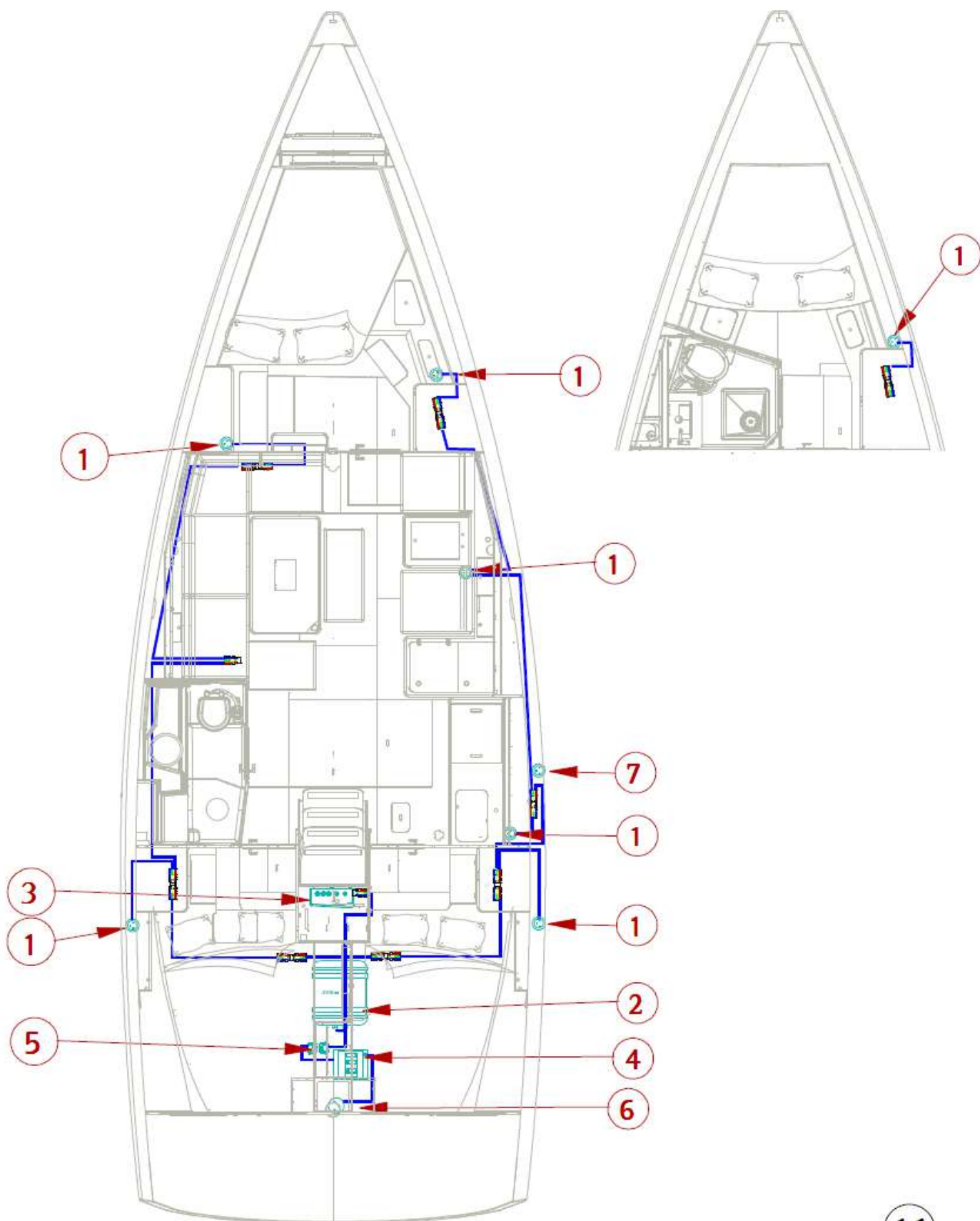

11

12- Fuse location diagram

<i>Label</i>	<i>Description</i>
A	Zone A - 12V Strip fuse 500A: optional bow thruster*
B	Zone B - 12V Differential circuit-breaker 110A: windlass* Blade fuse 30A: inverter protection* Blade fuse 15A: Refrigeration unit* Blade fuse 1A: with gas solenoid valve* Blade fuse 10A: optional bow thruster* Blade fuse 15A: Exterior fridge* Blade fuse 40A: with auto-pilot option* Blade fuse 10A: heating option* Blade fuse 5A: with windlass option* Blade fuse 5A: with navigation instrument pack option* Resettable circuit breaker type C 16A: electric toilet*
C	Zone C - 12V Strip fuse 160A: panel protection Blade fuse 10A: bilge fan Blade fuse 15A: optional automatic bilge pump* Blade fuse 15A: optional exterior fridge*
D	Zone D - 220V 6-way box Differential circuit-breaker 16A: air conditioning protection* Single-pole + neutral circuit breaker: A/C compressor protection (x3)*
E	Zone E - 12V Differential circuit-breaker 90A: electric halyard winch.* Differential circuit-breaker 100A: electric genoa winch (x2)* Single-pole 6A circuit breaker: rear door piston cover*
F	Zone F - 220V 2-pole circuit breaker: shore protection

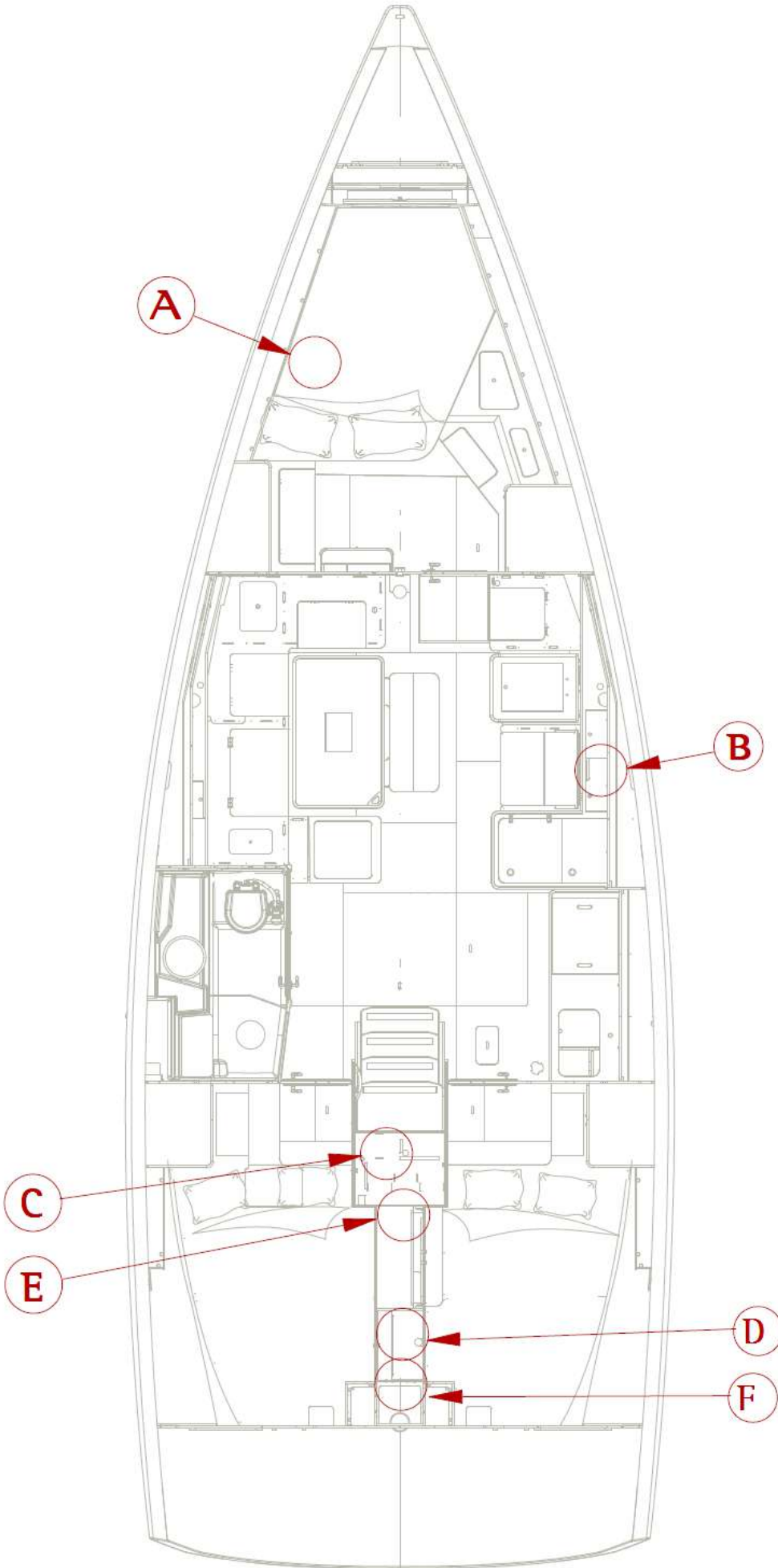

13. Steering system diagram

<i>Label</i>	<i>Description</i>
1	Rudder blade + stock
2	Rudder trunk
3	Lower bearing
4	Lower bearing and rudder rings
5	Top bearing
6	80 deg section
7	Section stop
8	Chain and rudder cable kit
9	Rudder cable sheaves
10	Spacer sheaves
11	Steering cable guide plates
12	Port bulkhead devices
13	Starboard bulkhead device + brake
14	Steering wheel
15	Autopilot motor*
16	Pilot bracket shims*
17	Helm angle indicator*
18	Emergency tiller*
*	Option

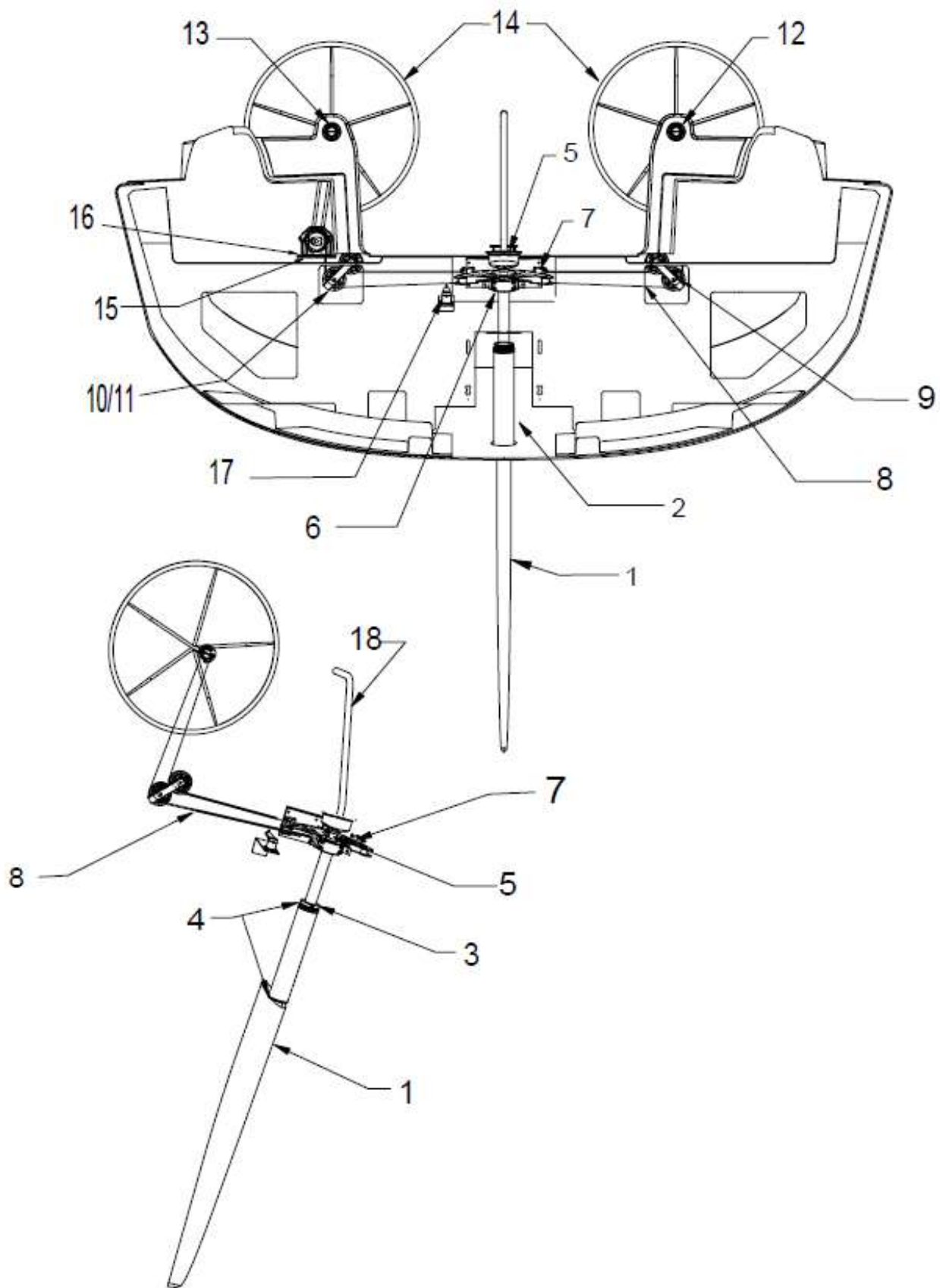

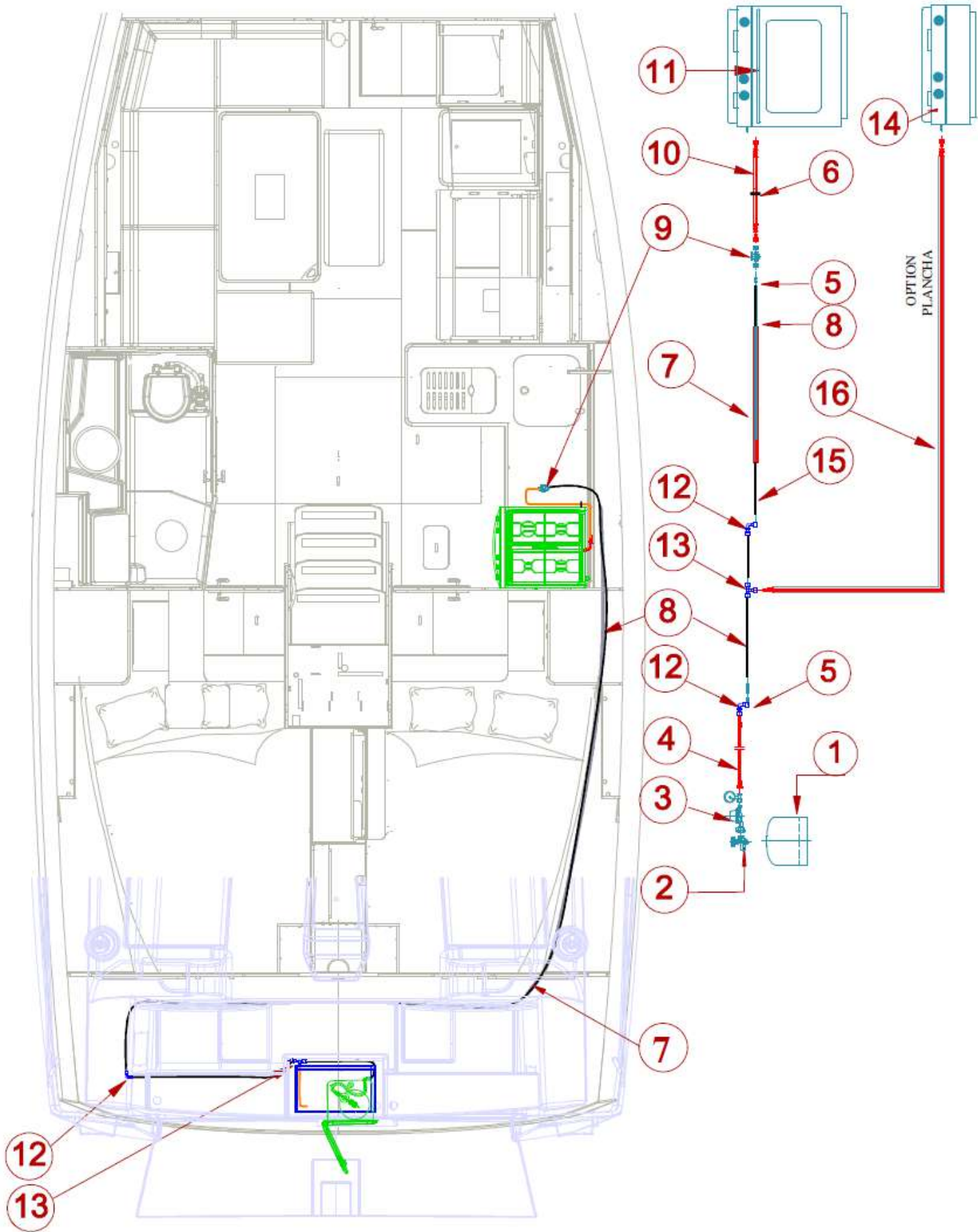

14. Gas system diagram

<i>Label</i>	<i>Description</i>
1	1.8 lbs (1.8 kg) gas cylinder**
2	CE shut-off valve (Fr. or Ger.) **
3	30 mbar CE regulator (Fr. or Ger.) ** / Pressure gauge**
4	Medium-length connecting hose
5	Spacer/tube 6 x 8
6	Watertight bulkhead fitting
7	PVC pipe
8	6 x 8 copper pipe
9	CE gas shut-off valve
10	Long connection hose
11	Cooker/Oven
12	Bulkhead gas locker
13	Gas T connector*
14	Foldaway*
15	Black split loom
16	Gas connector hose*
*	Gas T connector
**	Not supplied



15. Abandon ship plan

<i>Label</i>	<i>Description</i>
	Recommended fire-extinguisher locations
1	Saloon/pillar: 1 kg powder fire-extinguisher 5A/34B**
2	Galley unit: 1 kg powder fire-extinguisher 5A/34B**
3	Cockpit locker: 1 kg powder fire-extinguisher 5A/34B**
Wh	Engine compartment extinguisher hole
	Emergency exit
**	Not supplied

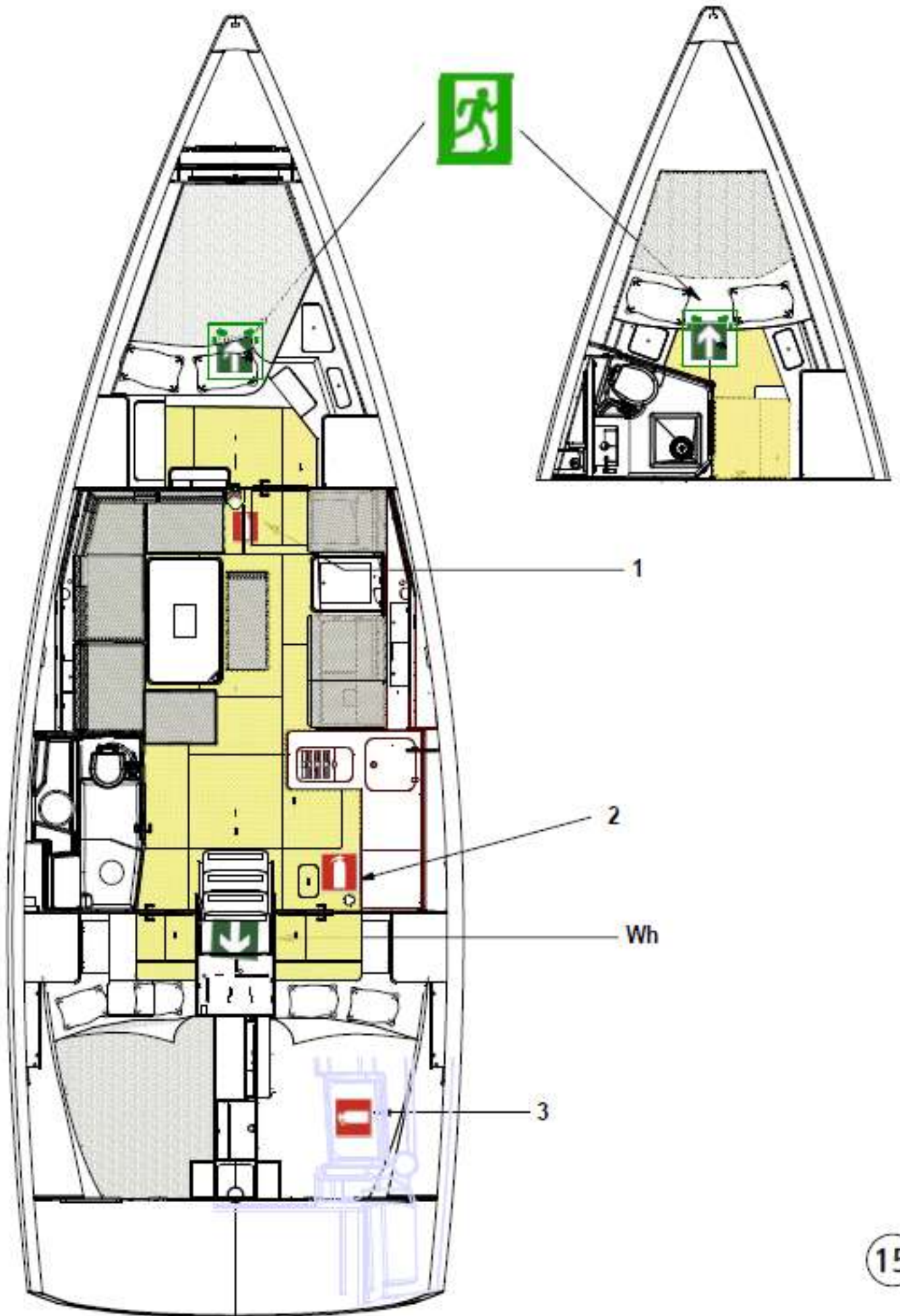

16. Fresh-water system diagram

<i>Label</i>	<i>Description</i>
1	Filler deck plate
2	Filler hose
3	Vent
4	Vent hose
5	Foreward water tank, 160 L
6	Stern water tank 200 L
7	Hot water pipe
8	Cold water pipe
9	Pressurized water pump unit
10	Fresh-water pump
11	Water heater
12	Head shower single-lever mixer tap
13	Galley single-lever mixer tap
14	Deck shower
15	Bathroom mixer tap
16	1/2" 2-way manifold
17	Plug M 3/4"
18	1/2" 1/4-turn FF seacock (x2)
19	3/4" F connector
20	1/2" M connector (x2)
21	Freshwater/seawater cock
22	Plug: Optional fore dressing table
23	Sea water foot pump
24	Toilet sea-water intake*
24	Foldaway mixer tap*
*	Option

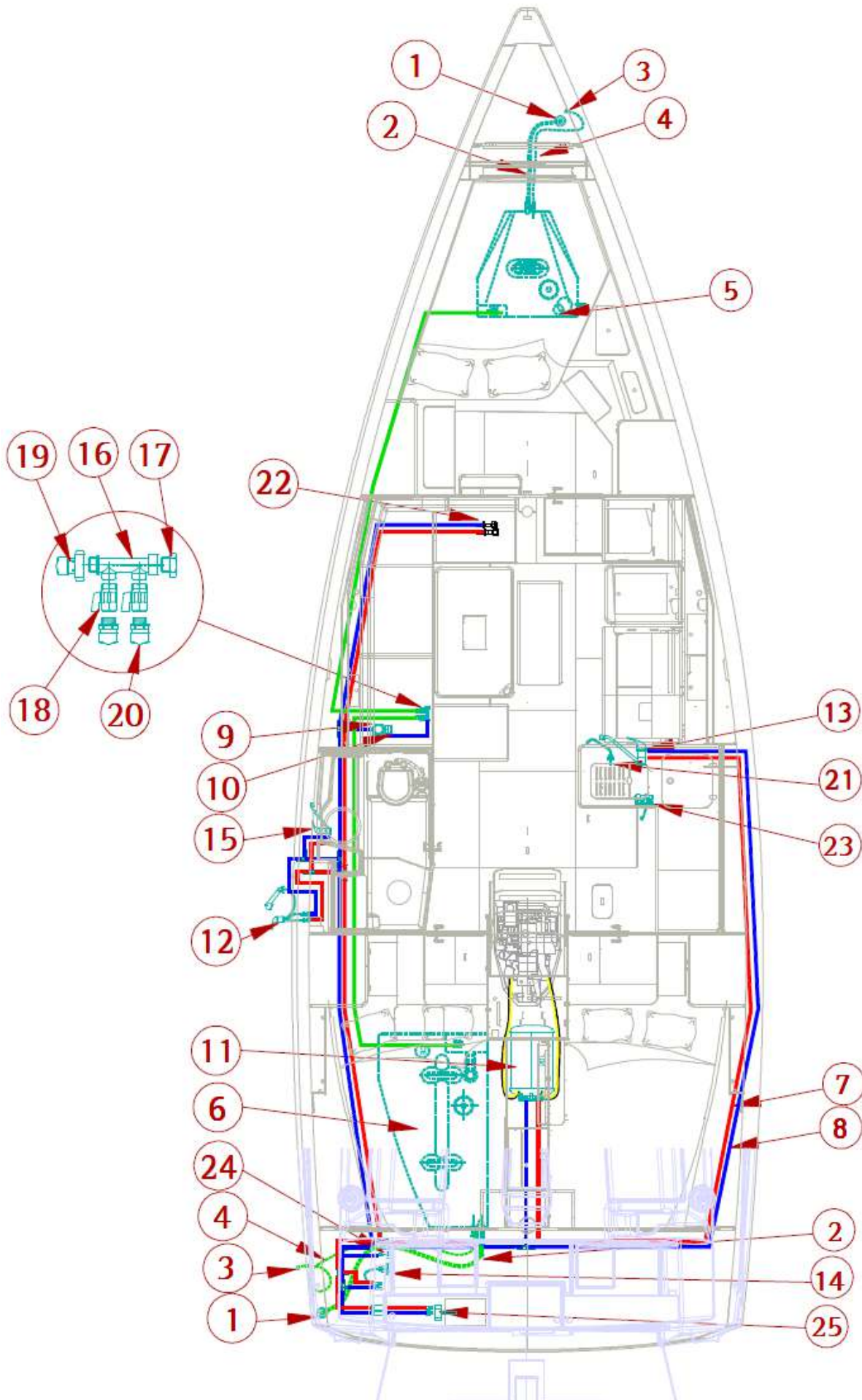

16

17. Drain system diagram

Label	Description
	<i>Electric bilge pump</i>
1	Ø25 discharge hose
2	Electric submersible bilge pump
3	Skin fitting 1"
	<i>Manual bilge pump</i>
4	D25 Strainer with non-return valve
5	Ø25 discharge hose
6	Manual bilge pump
7	Skin fitting 1"

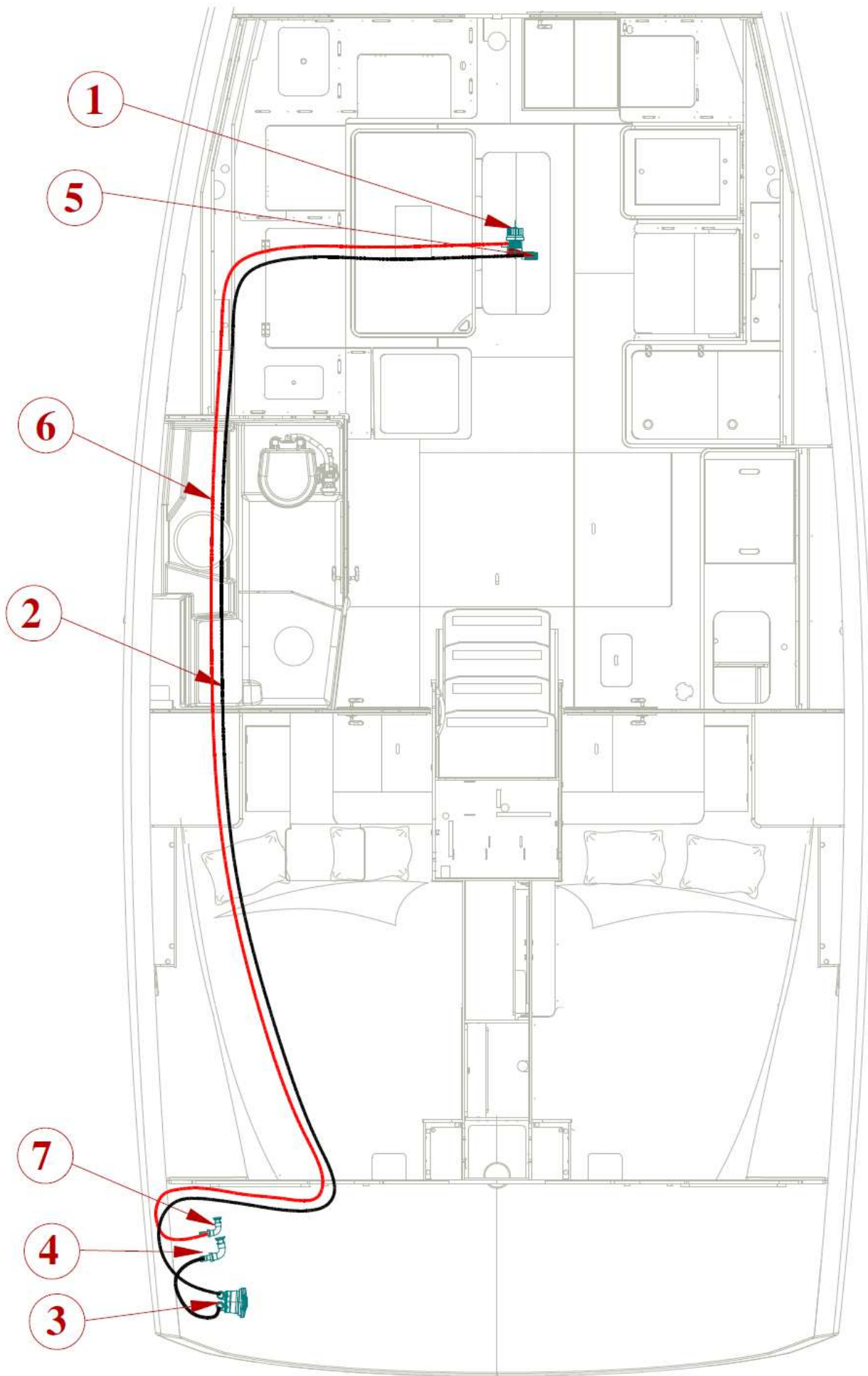

18. Skin fitting location diagram

<i>Label</i>	<i>Description</i>	<i>Ø -inch</i>
<i>Skin-fittings + seacocks</i>		
1	Galley sink discharge	1"
2	Wash-basin/shower outlet	1"
3	Toilet sea-water intake	3/4"
4	Toilet discharge	1-1/2"
5	Dressing table sink discharge*	3/4"
6	Foot pump sea water intake	1/2"
7	Anchor locker discharge (x2)	1"
12	Air-conditioning discharge* (x3)	1/2"
<i>Skin-fitting</i>		
8	Electric bilge pump discharge	1"
9	Manual bilge pump discharge	1"
10	Cockpit sink discharge*	1"
<i>Strainer skin fitting*</i>		
11	Sea-water intake for air-conditioning (x3)*	1/2"
*	Option	

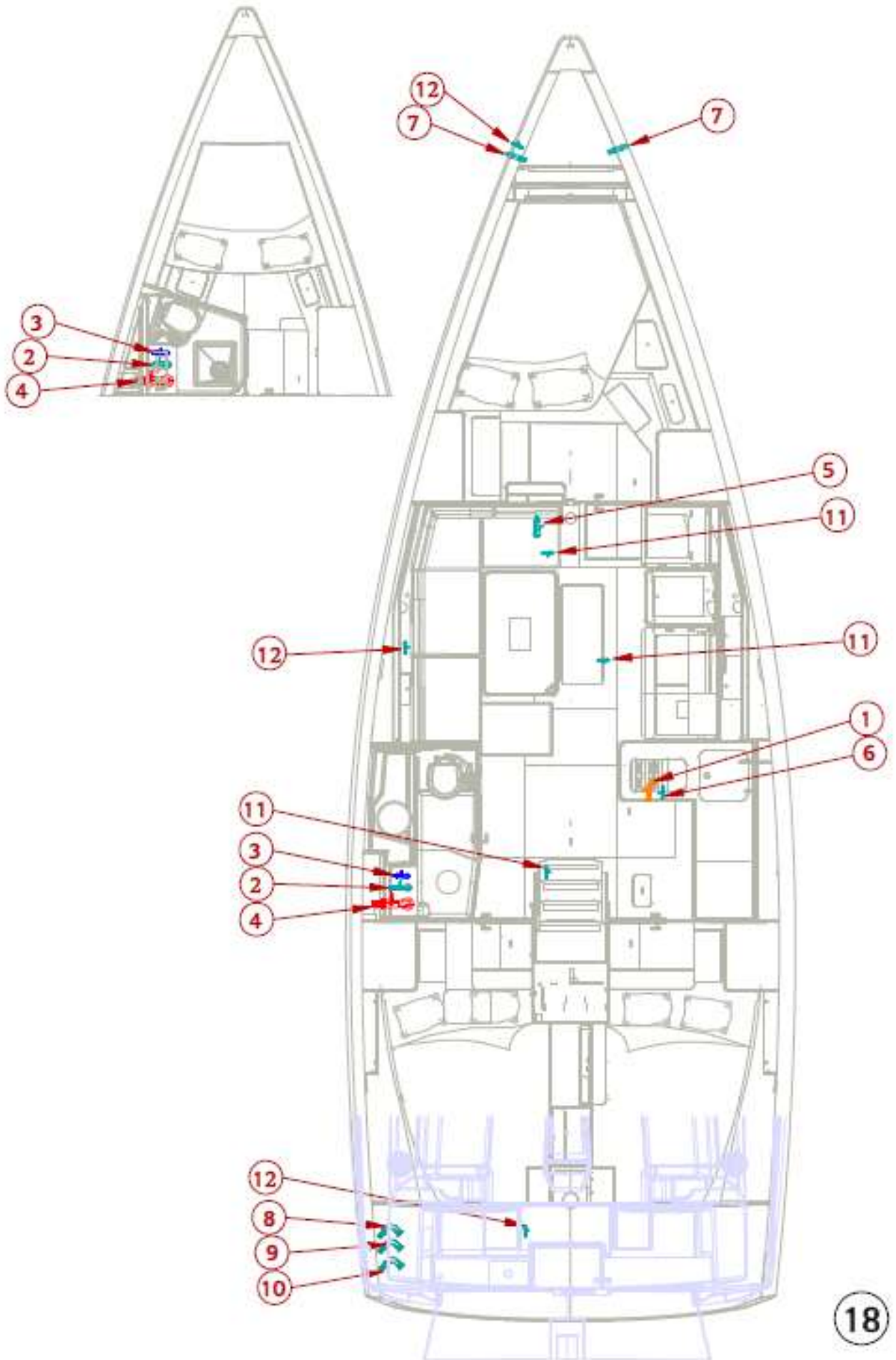

19. Mechanical installation diagram

<i>Label</i>	<i>Description</i>
1	Fuel tank
2	Fuel shut-off valve
3	Anode
4	Polyester frame
5	Propeller
6	Overflow vent
7	Fuel deck plate
8	Tank vent
9	Sail Drive
10	Engine
11	Ventilation grilles
12	Fuel pre-filter
13	Foam insulation
14	Control panel
15	Exhaust outlet
16	Anti-siphon elbow
17	Sea water intake seacock
18	Raw water strainer
19	Waterlock silencer
20	Bilge fan
21	Engine battery
22	Charge splitter
23	Isolator

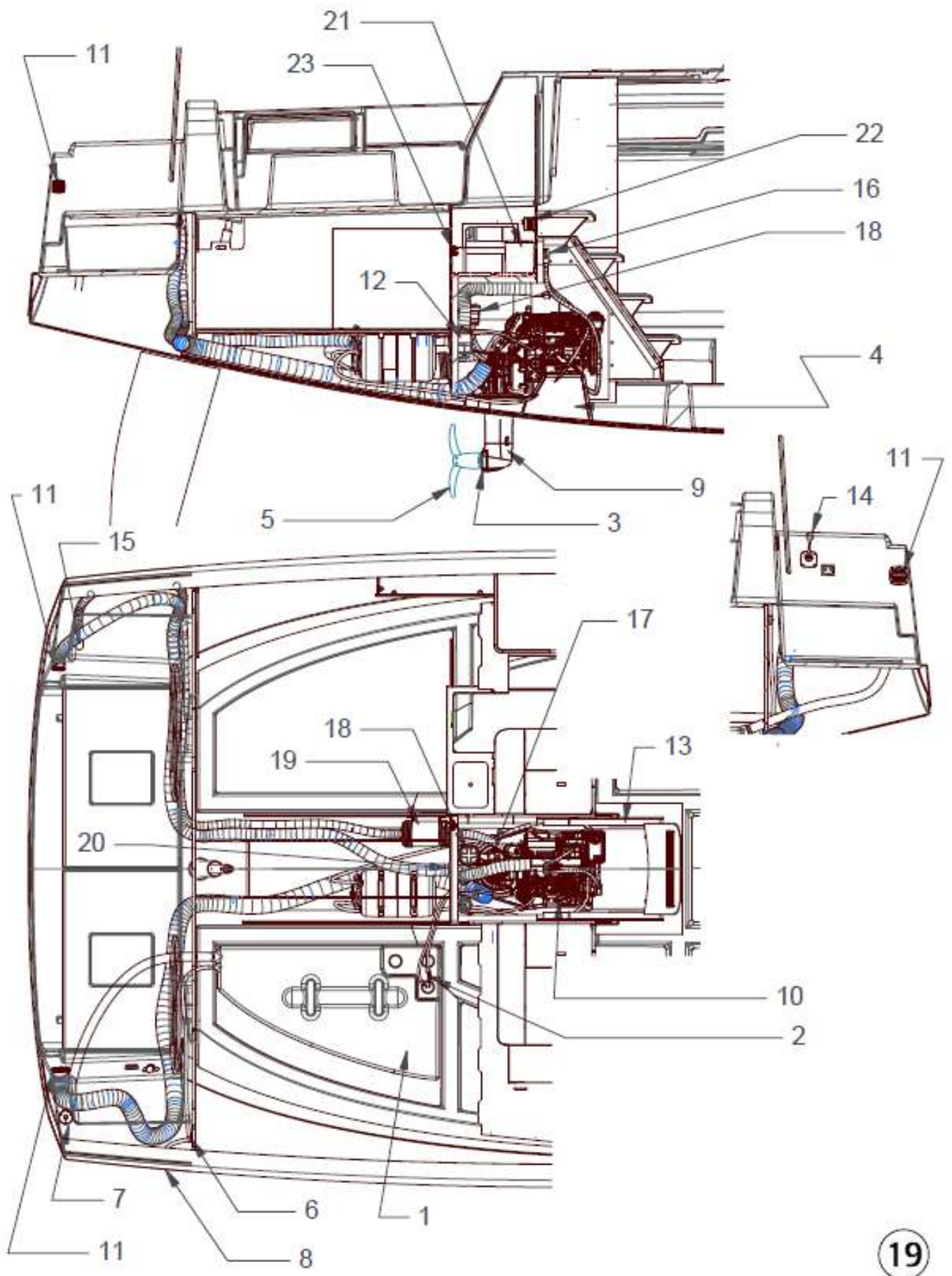

19

20. Holding tank installation diagram

<i>Label</i>	<i>Description</i>
1	Skin fitting & seacock, 3/4"
2	50 mm Ø Waste deck plate
3	Skin fitting & seacock, 1-1/2"
4	20 mm Ø hose
5	38 mm Ø anti-odour hose
6	51 mm Ø anti-odour hose
7	3/4" chromed brass vent
8	50 L polythene holding tank
9	45 L polythene holding tank*
X	U-bend
*	Option

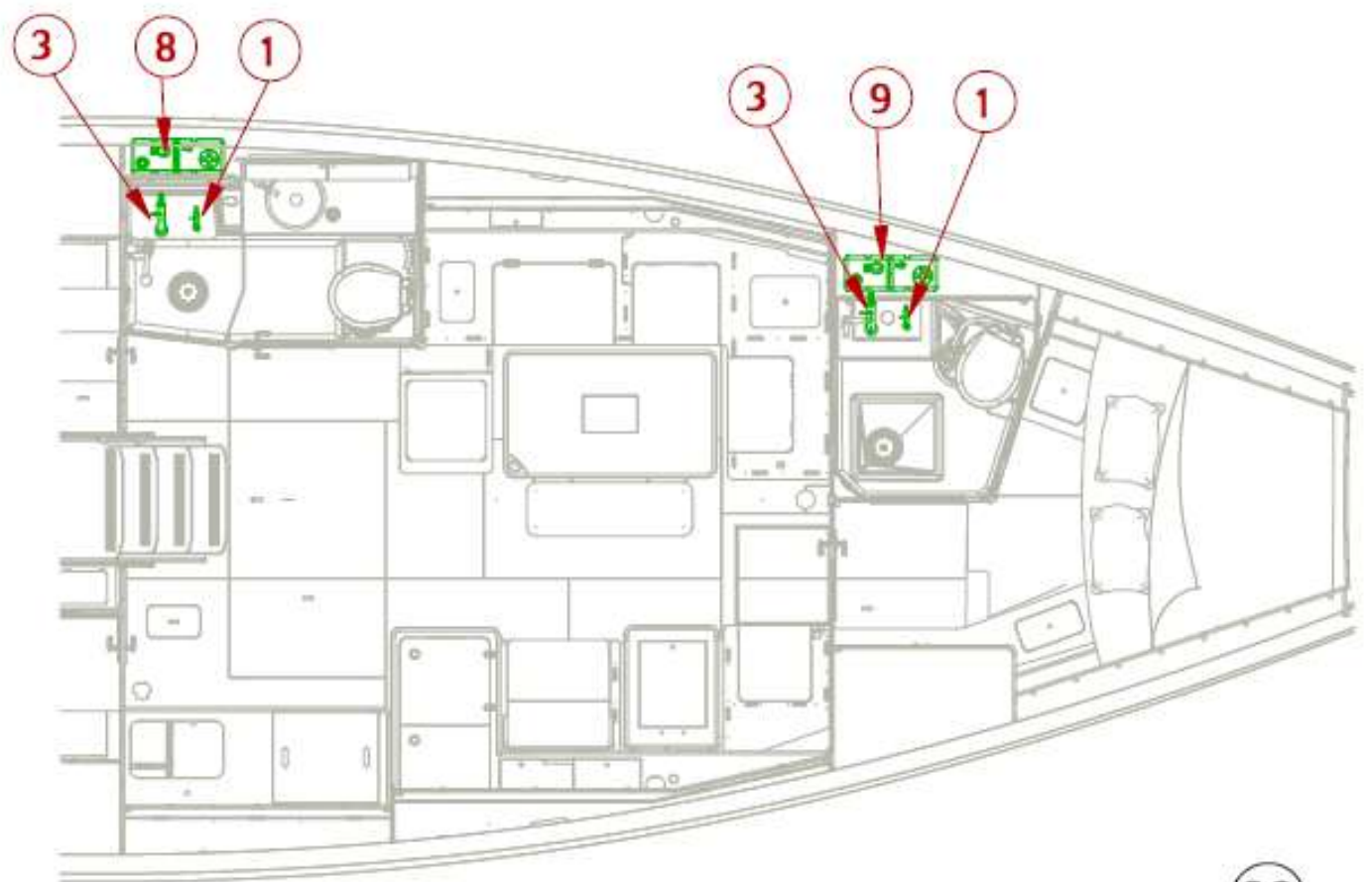
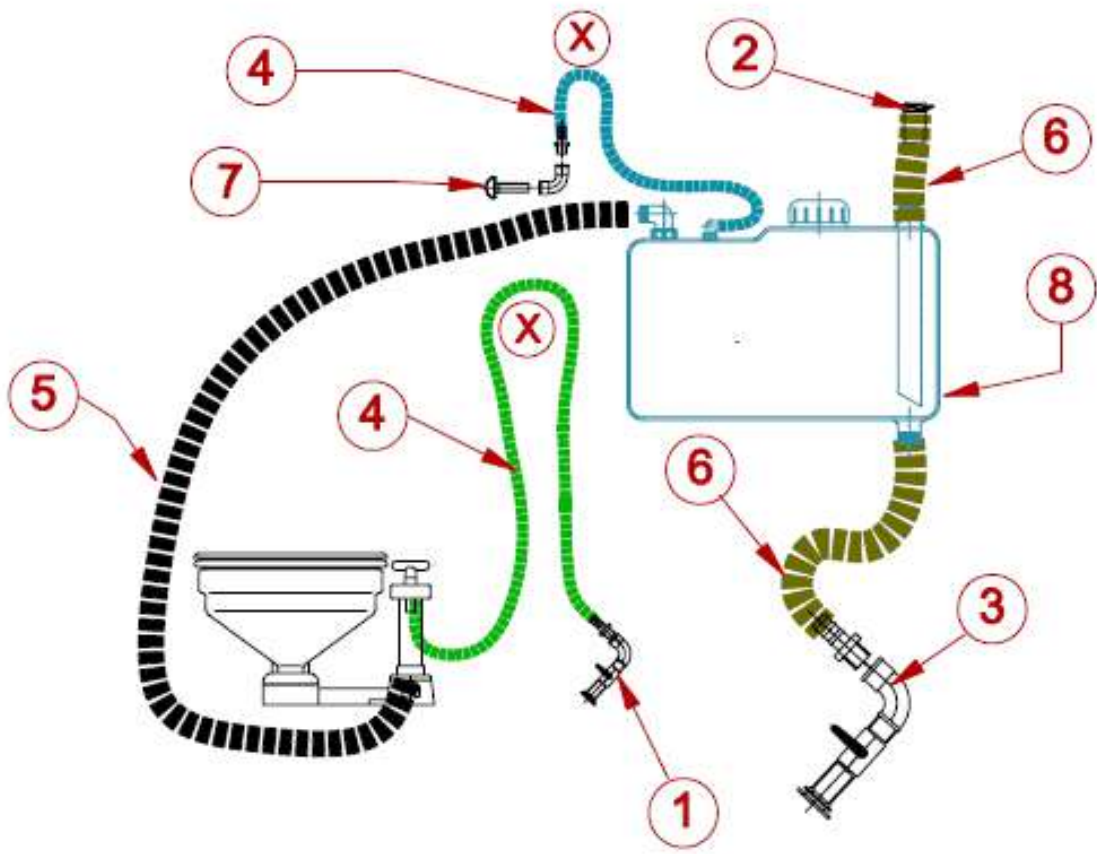

21. Lifting diagram

<i>Label.</i>	<i>Description</i>
	See red triangular marker under deck-line
	Light displacement: 8,940 kg
	Midship beam: 4.20 m
	Standard Draught: 2.10 m

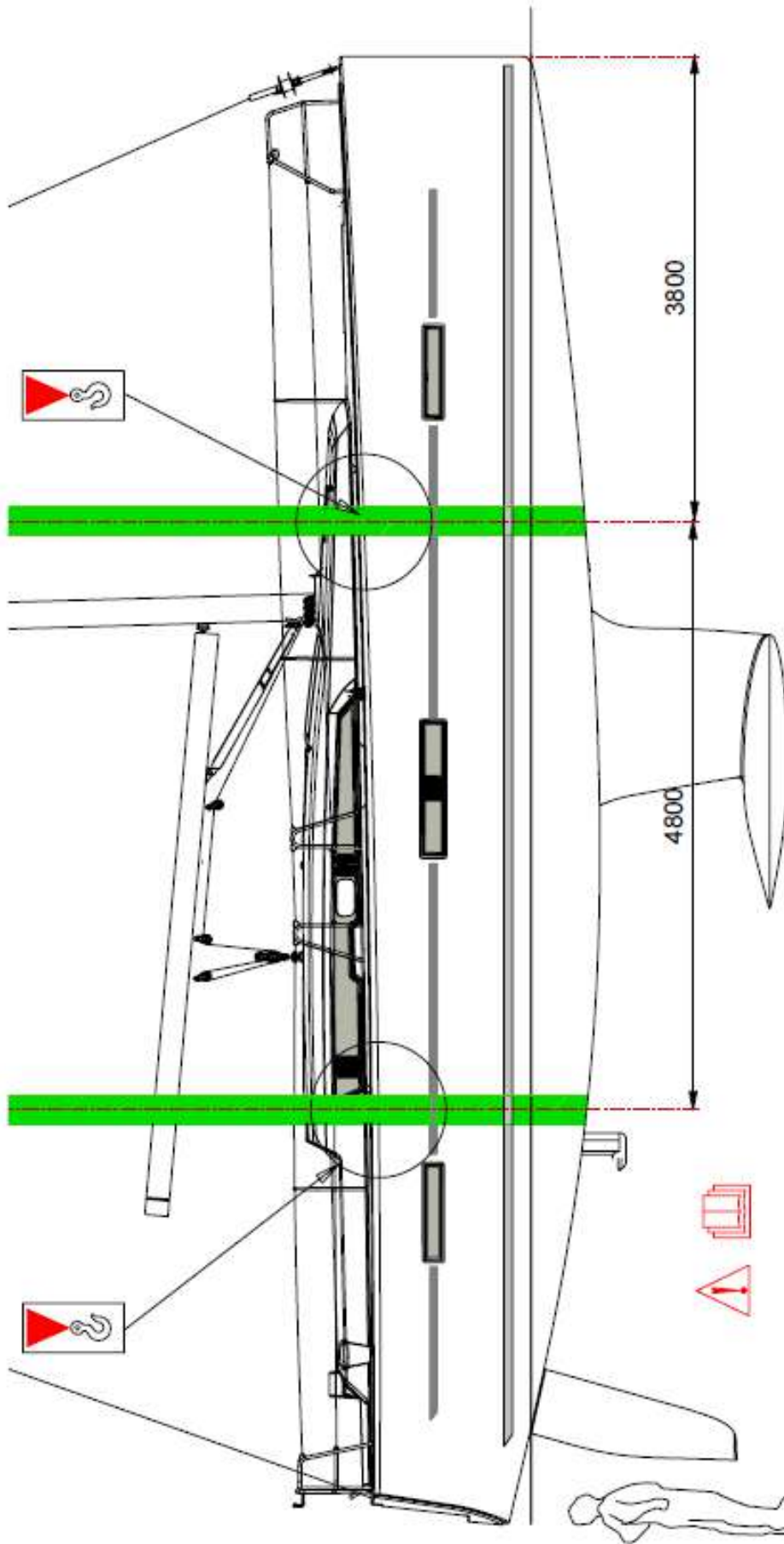



NOTES