



A Garmin Brand

FUSION® MS-RA70/MS-RA70N INSTALLATION INSTRUCTIONS

Important Safety Information

WARNING

Failure to follow these warnings and cautions could result in personal injury, damage to the vessel, or poor product performance.

See the *Important Safety and Product Information* guide in the product box for product warnings and other important information.

This device must be installed according to these instructions.

Disconnect the vessel's power supply before beginning to install this product.

Before applying power to this product, make sure it has been correctly grounded, following the instructions in the guide.

CAUTION

To avoid possible personal injury, always wear safety goggles, ear protection, and a dust mask when drilling, cutting, or sanding.

NOTICE

When drilling or cutting, always check what is on the opposite side of the surface to avoid damaging the vessel.

You must read all installation instructions before beginning the installation. If you experience difficulty during the installation, contact Fusion Product Support.

What's In the Box

- DIN mounting plate
- Four 8-gauge, self-tapping screws
- Power and speaker wiring harness
- Auxiliary-in, line-out, and subwoofer-out wiring harness

Tools Needed

- Phillips screwdriver
- Electric drill
- Drill bit (size varies based on surface material and screws used)
- Rotary cutting tool or jigsaw
- Silicone-based marine sealant (optional)

Mounting Considerations

- The stereo can be mounted on a flat surface or in a single-DIN opening as a replacement for an existing stereo.
- The stereo must be mounted in a location that allows open airflow around the rear of the stereo for heat ventilation.



- If you are installing the stereo in a location that may be exposed to water, it must be mounted within 45 degrees of the horizontal plane.

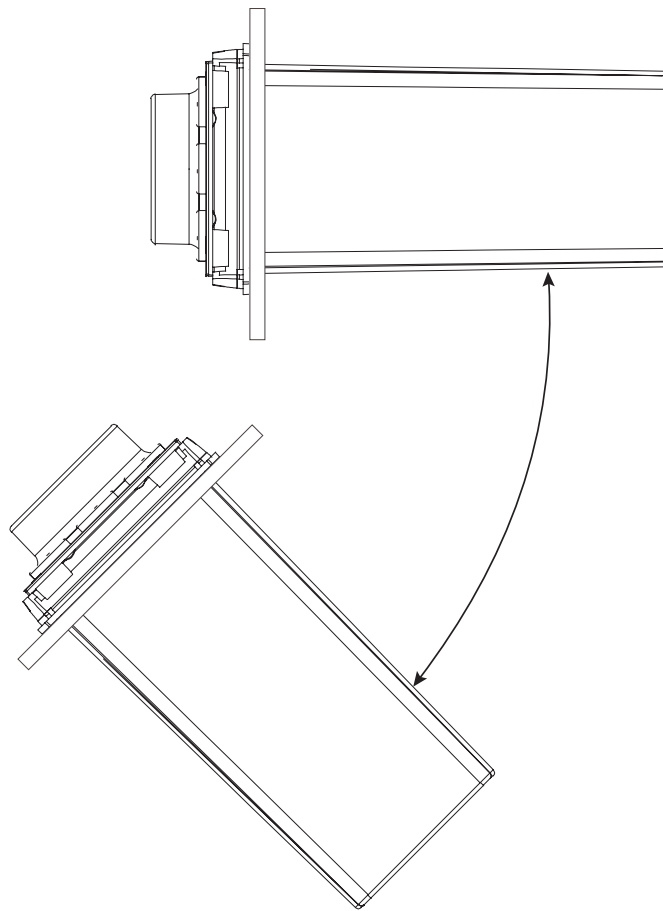

- If you are installing the stereo in a location that may be exposed to water, the cable should have a drip loop to allow water to drip down off the cable and avoid damage to the stereo.
- If you need to mount the stereo outside a boat, it must be mounted in a location far above the waterline, where it is not submerged.
- If you need to mount the stereo outside a boat, it should be mounted in a location where it cannot be damaged by docks, pilings, or other pieces of equipment.
- To avoid interference with a magnetic compass, the stereo should be installed at least 15 cm (5.9 in.) away from a compass.

Mounting the Stereo in a New Location

NOTICE

Be careful when cutting the hole to mount the stereo. There is only a small amount of clearance between the case and the mounting holes, and cutting the hole too large could compromise the stability of the stereo after it is mounted.

Before you can mount the stereo in a new location on the mounting surface, you must select a location in accordance with the mounting considerations.

- 1 Trim the template and make sure it fits at the mounting location.
- 2 Adhere the template to the mounting surface.
- 3 Using a drill bit appropriate for the mounting surface, drill a hole inside the corner of the dashed line on the template to prepare the mounting surface for cutting.
- 4 Using a rotary-cutting tool, cut the mounting surface along the inside of the dashed line on the template.
- 5 Place the stereo in the cutout to test the fit.
- 6 If necessary, use a file and sandpaper to refine the size of the cutout.
- 7 After the stereo fits correctly in the cutout, ensure the mounting holes on the stereo line up with the pilot holes on the template.
- 8 If the mounting holes on the stereo do not line up, mark the new pilot-hole locations.
- 9 Using an appropriately sized drill bit for the mounting surface and screw type, drill the pilot holes.
- 10 Remove the template from the mounting surface.
- 11 Make the necessary wiring connections ([Connection Considerations](#), page 4).
- 12 Place the mounting gasket on the back of the stereo ①.

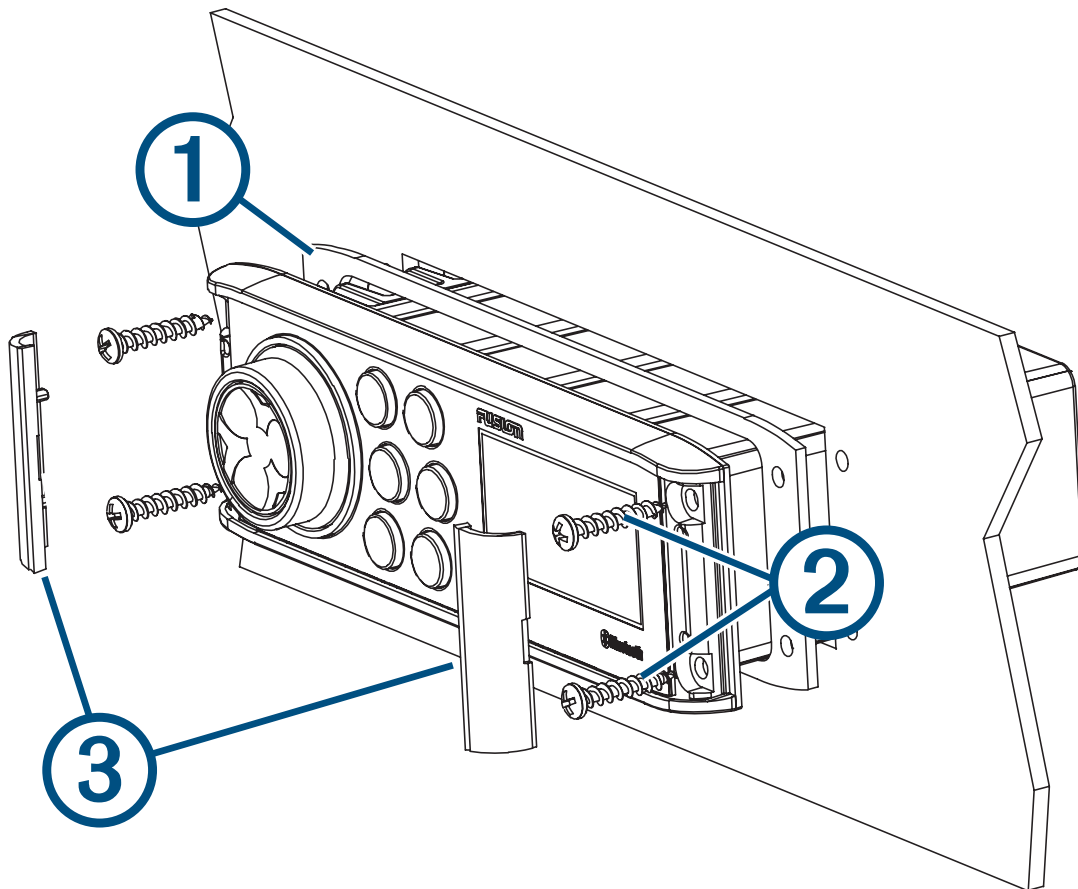

13 Place the stereo in the cutout.

14 Secure the stereo to the mounting surface using the included screws ②.

15 Snap the screw covers in place ③.

Replacing an Existing Stereo

1 Remove and disconnect the existing stereo.

2 If necessary, remove the existing wiring harness or install a vehicle- or vessel-specific wiring-harness adapter (not included) to provide access to the power and speaker wiring.

3 Place the mounting gasket on the back of the stereo ①.

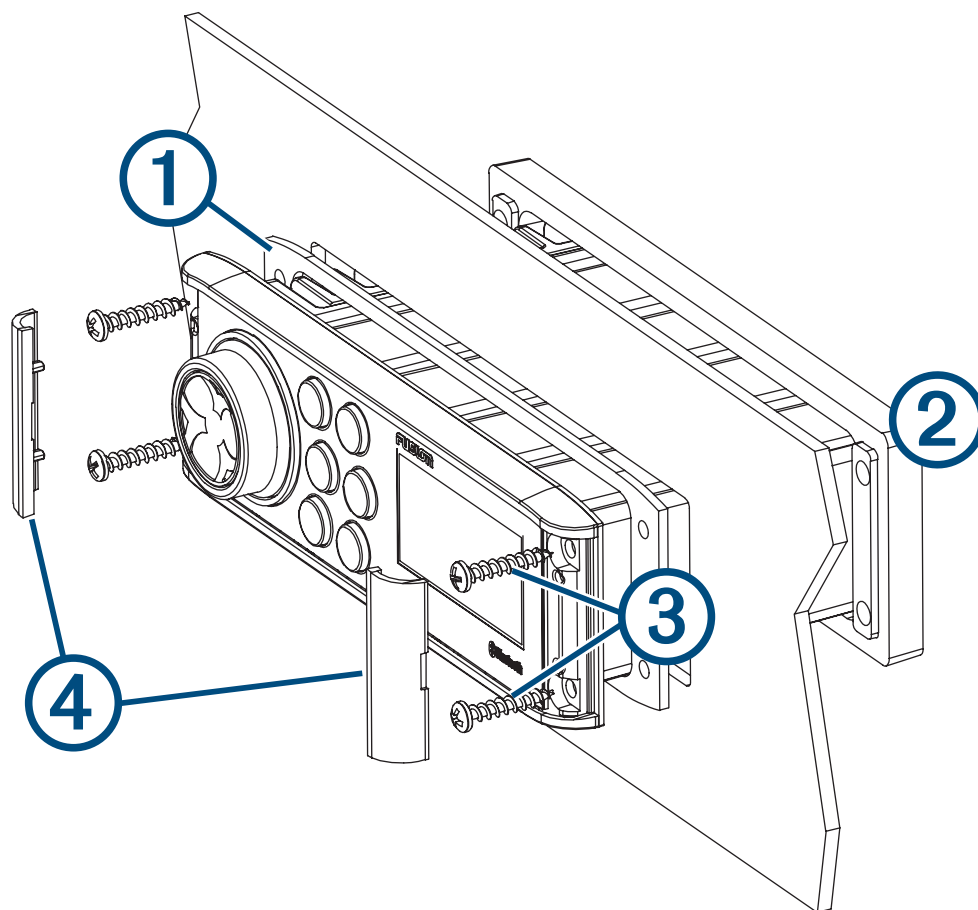

4 Place the mounting bracket ② behind the mounting surface.

5 Make the necessary wiring connections ([Connection Considerations](#), page 4).

6 Place the stereo in the opening.

7 Secure the stereo to the mounting bracket using the included screws ③.

NOTE: You might need to reach behind the mounting surface to hold the bracket in place when securing the stereo to the bracket.

8 Snap the screw covers in place ④.

Connection Considerations

The stereo must be connected to power, to speakers, and to media input sources to function correctly. You should carefully plan the layout of the stereo, wired remote, speakers, optional NMEA 2000® network, and your input sources before making any connections.

Port Identification

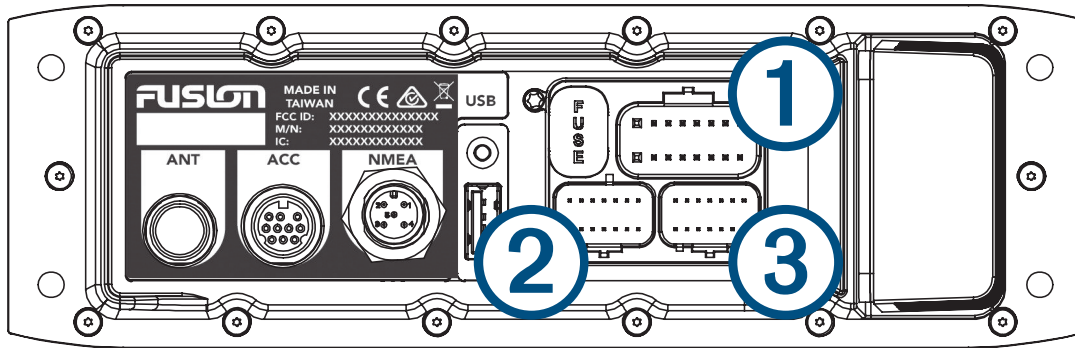

Item	Description
ANT	Connects the stereo to a typical AM/FM antenna using an RF coaxial connector. If you are installing the stereo on a boat with a metal hull, you must use a ground-dependent antenna, and if you are installing the stereo on a boat with a non-metal hull, you must use a ground-independent antenna. See the installation instructions provided with your antenna for more information.
ACC	Connects to a Fusion DAB module to receive DAB stations where available (not included).
NMEA	Connects the stereo to a NMEA 2000 network ("N" models only) (NMEA 2000 System Wiring Diagram, page 11).
USB	Connects the stereo to a USB source.
FUSE	Contains the fuse for the device. See the device specifications for replacement fuse information.
①	Connects the stereo to the power and speaker wiring harness.
②	Connects the stereo to the auxiliary in and line/subwoofer out wiring harness.
③	Reserved for future use.

Wiring Harness Wire and Connector Identification

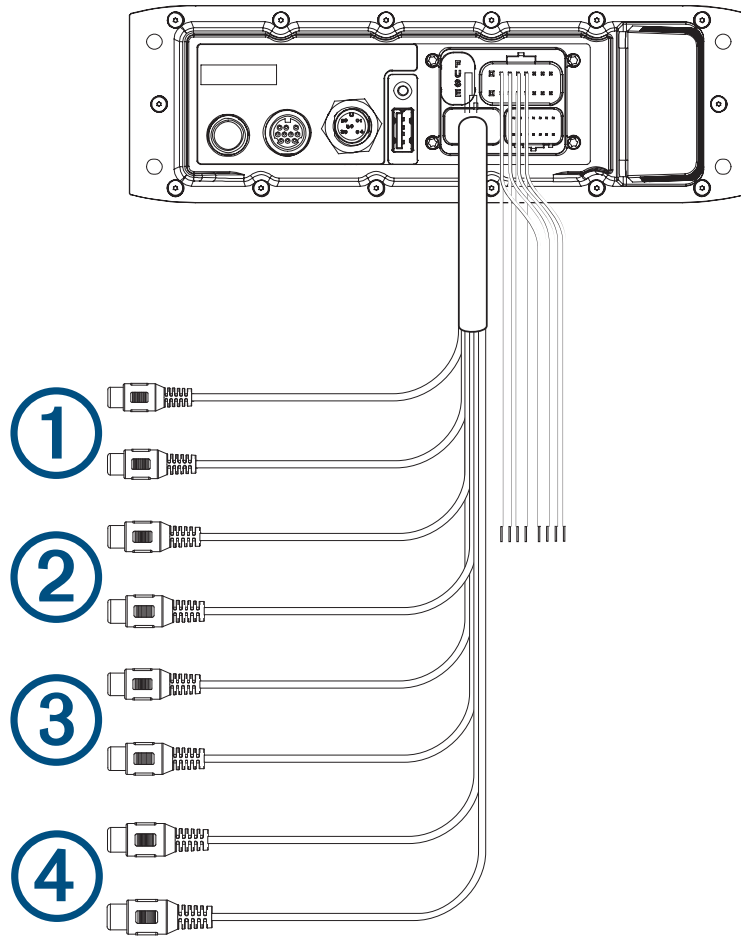

Wire Function	Wire Color/ Number	Notes
Power (+)	Red (yellow on some wire harnesses)	Connects to the positive terminal of a 12 Vdc power source capable of supplying 15 A.
Ground (-)	Black	Connects to the negative terminal of a 12 Vdc power source capable of supplying 15 A. This wire should be connected before connecting the red (or yellow) wire. All accessories connected to the stereo must share a common ground location.
Amplifier on	Blue	Connects to an optional external amplifier to turn it on when the stereo turns on.
Mute	Brown	Activates when connected to ground. For example, when connected to a compatible hands-free mobile kit, the audio mutes or the input switches to AUX when a call is received and the kit connects this wire to ground. This functionality can be configured from the settings menu.
Dim	Orange	Connects to the boat's illumination wire to dim the stereo screen when the lights are on. The gauge of the illumination wire must be suitable for the fuse supplying the circuit it is connected to.
Speaker zone 1 left (+)	White	
Speaker zone 1 left (-)	White/black	
Speaker zone 1 right (+)	Gray	
Speaker zone 1 right (-)	Gray/black	
Speaker zone 2 left (+)	Green	
Speaker zone 2 left (-)	Green/black	
Speaker zone 2 right (+)	Purple	
Speaker zone 2 right (-)	Purple/black	
Auxiliary in left Auxiliary in right	①	Provides a red and white RCA stereo line input for audio sources, such as a CD or MP3 player.
Zone 1 line out (left) Zone 1 line out (right)	②	Provides a full-range output to an external amplifier, and is associated with the volume control for zone 1.
Zone 2 line out (left) Zone 2 line out (right)	③	Provides a full-range output to an external amplifier, and is associated with the volume control for zone 2.
Subwoofer out	④	Each cable provides a single mono output to a powered subwoofer or subwoofer amplifier, and one or both cables can be used, depending on the connection requirements of the subwoofer or amplifier. A connected subwoofer is associated with the volume control for zone 1.

Connecting to Power

When connecting the stereo to power, you should connect it through the ignition or another manual switch. If it is necessary to extend the power and ground wires, use 14 AWG (2.08 mm²) wire. For extensions longer than 1 m (3 ft.), use 12 AWG (3.31 mm²) wire.

- 1 Route the red power wire ① to the ignition or another manual switch ②, and route the black ground wire ③ to the battery.

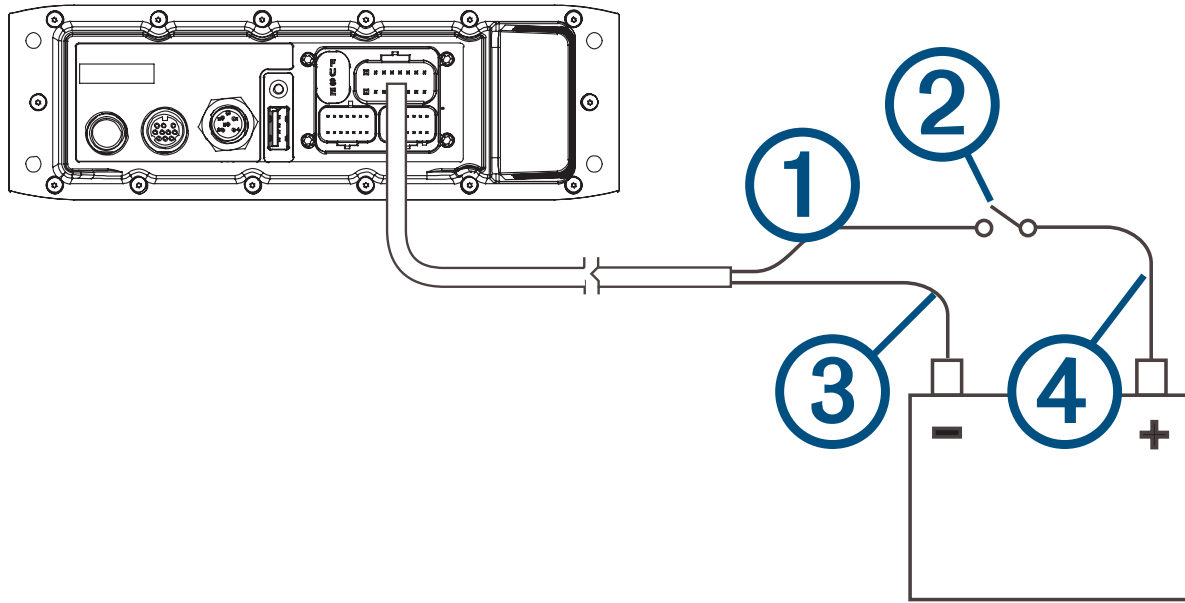

- 2 If necessary, route a wire ④ between the switch and the battery .
- 3 Route the wiring-harness plug to the stereo.
Do not connect the wiring harness to the stereo until after all of the bare wire connections have been made.
- 4 Connect the black wire to the negative (-) battery terminal.
- 5 Connect the red power wire to the ignition or another manual switch, and connect the switch to the positive (+) battery terminal if necessary.
- 6 Connect the wiring harness plug to the stereo.

Speaker Zones

You can group speakers in one area into speaker zones. This enables you to control the audio level of the zones individually. For example, you could make the audio quieter in the cabin and louder on deck.

You can set the balance, volume limit, subwoofer level, and name for each zone.

Single-Zone System Wiring Example

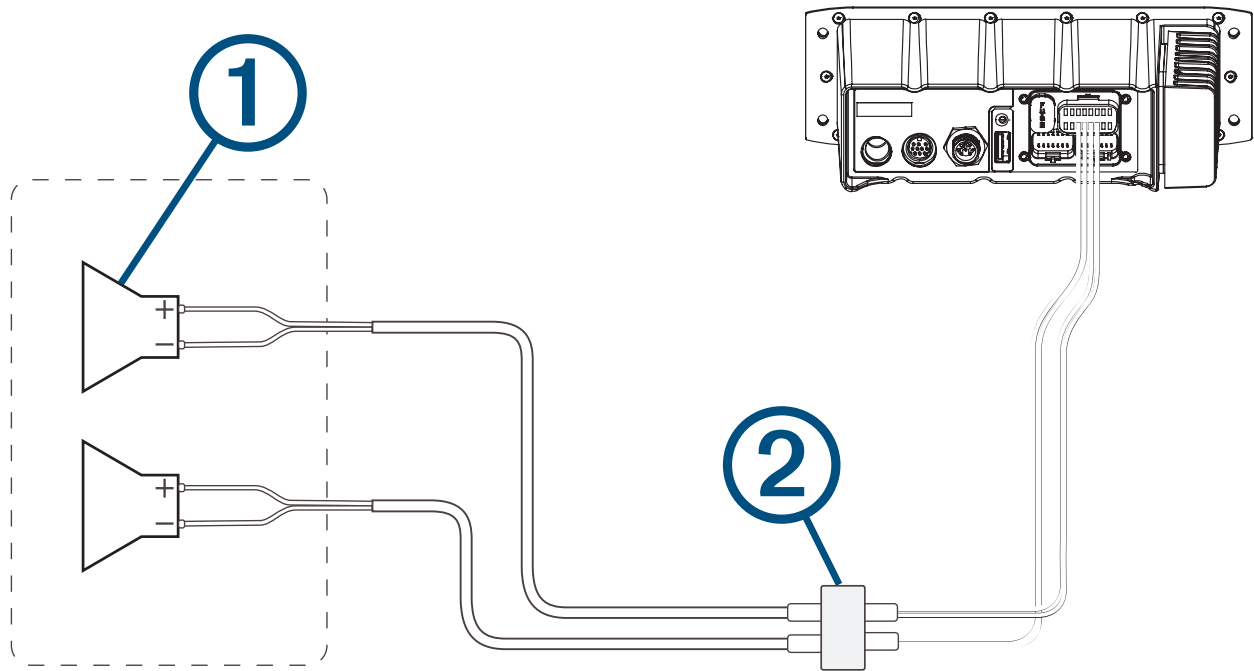

①

Speakers

②

Water-tight connection

Complete System Wiring

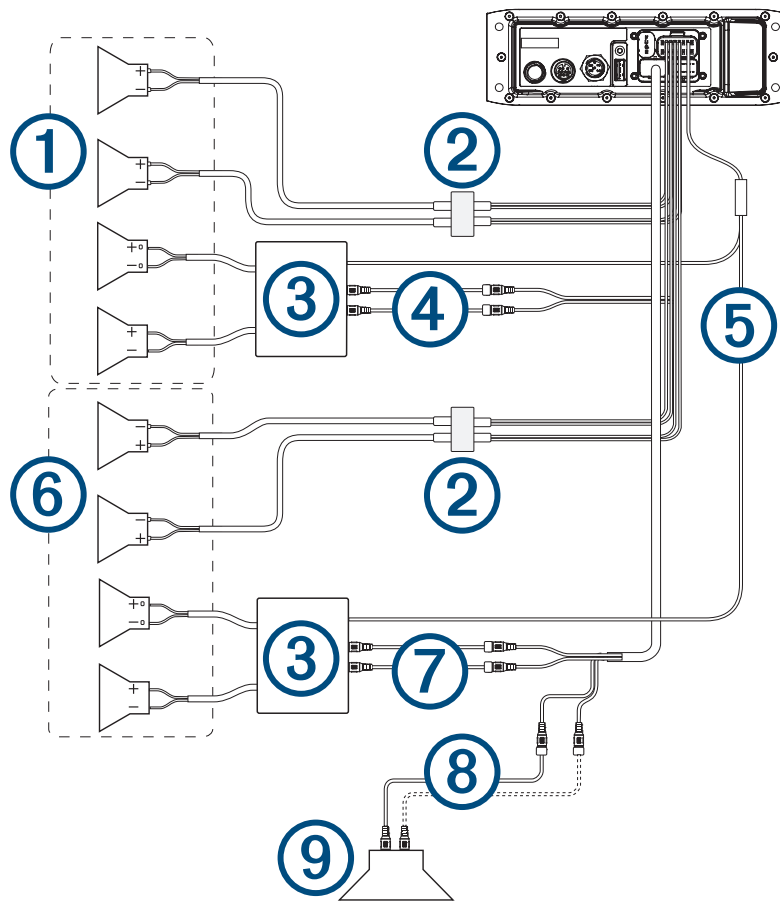

Item	Description
①	Zone 2 speakers
②	Water-tight connection
③	Powered amplifier
④	Zone 2 line out
⑤	Amplifier-on signal wire
⑥	Zone 1 speakers
⑦	Zone 1 line out
⑧	Zone 1 subwoofer out Each cable provides a single mono output to a powered subwoofer or subwoofer amplifier, and one or both cables can be used, depending on the connection requirements of the subwoofer or amplifier.
⑨	Powered subwoofer

NMEA 2000 System Wiring Diagram

NOTE: NMEA 2000 is available on Fusion MS-RA70N models only.

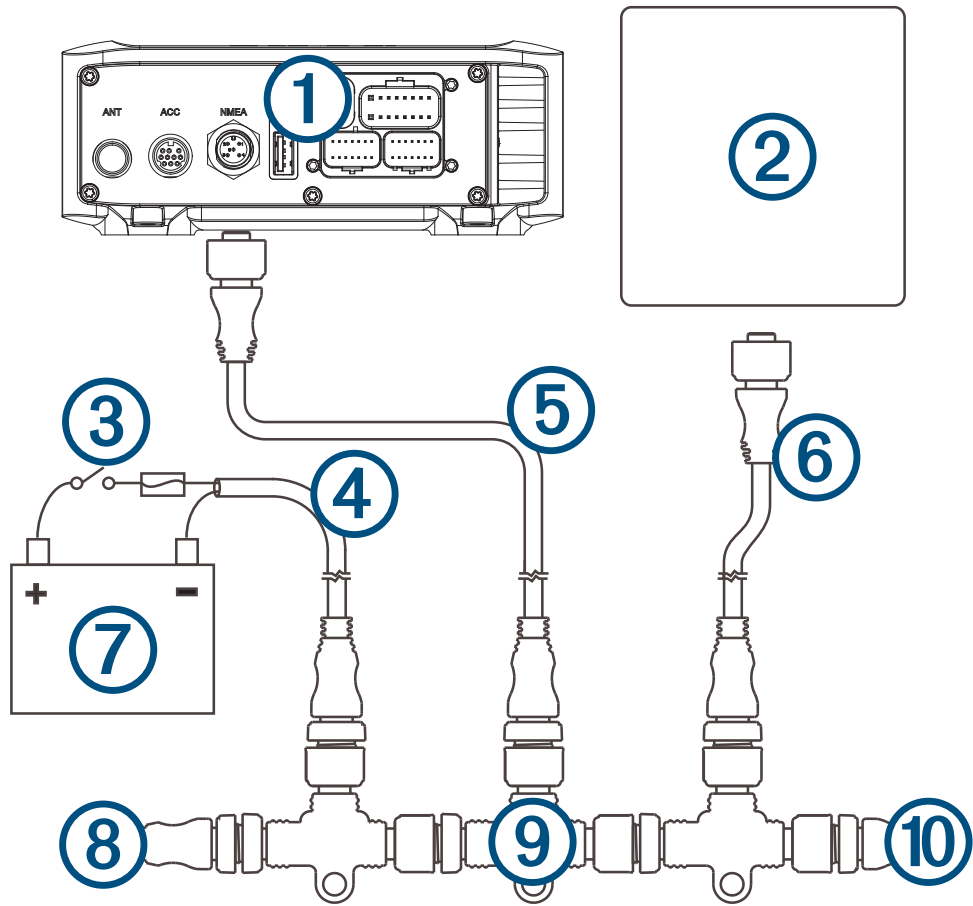

①	Stereo
②	Supported chartplotter MFD or compatible Fusion NMEA 2000 remote control
③	In-line switch
④	NMEA 2000 power cable
⑤	NMEA 2000 drop cable from the stereo, up to 6 m (20 ft.)
⑥	NMEA 2000 drop cable from the chartplotter MFD or compatible Fusion NMEA 2000 remote control
⑦	9 to 16 Vdc power supply
⑧	NMEA 2000 terminator or backbone cable
⑨	NMEA 2000 T-connector
⑩	NMEA 2000 terminator or backbone cable

Stereo Information

Specifications

General	
Weight	556 g (19.6 oz.)
Water resistance	IEC 60529 IPX7 (front), IEC 60529 IPX3 (rear)
Operating temperature range	From 0 to 50°C (from 32 to 122°F)
Storage temperature range	From -20 to 70°C (from -4 to 158°F)
Input voltage	From 10.8 to 16 Vdc
Current (max.)	15 A
Current (muted)	Less than 900 mA
Current (standby)	Fusion MS-RA70: less than 5 mA Fusion MS-RA70N: less than 15 mA
NMEA 2000 LEN	1 (50 mA)
ANT® wireless range	Up to 3 m (10 ft.)
Compass-safe distance	15 cm (5.9 in.)

On-board, Class AB Amplifier	
Output music power per channel	50 W max. x 4 channels at 4 ohm per channel
Total output music power	200 W max.

Tuner	Europe and Australasia	USA	Japan
FM radio frequency range	87.5 to 108 MHz	87.5 to 107.9 MHz	76 to 95 MHz
FM frequency step	50 kHz	200 kHz	50 kHz
AM radio frequency range	522 to 1620 kHz	530 to 1710 kHz	522 to 1620 kHz
AM frequency step	9 kHz	10 kHz	9 kHz

Stereo Dimension Drawings

Front Dimensions

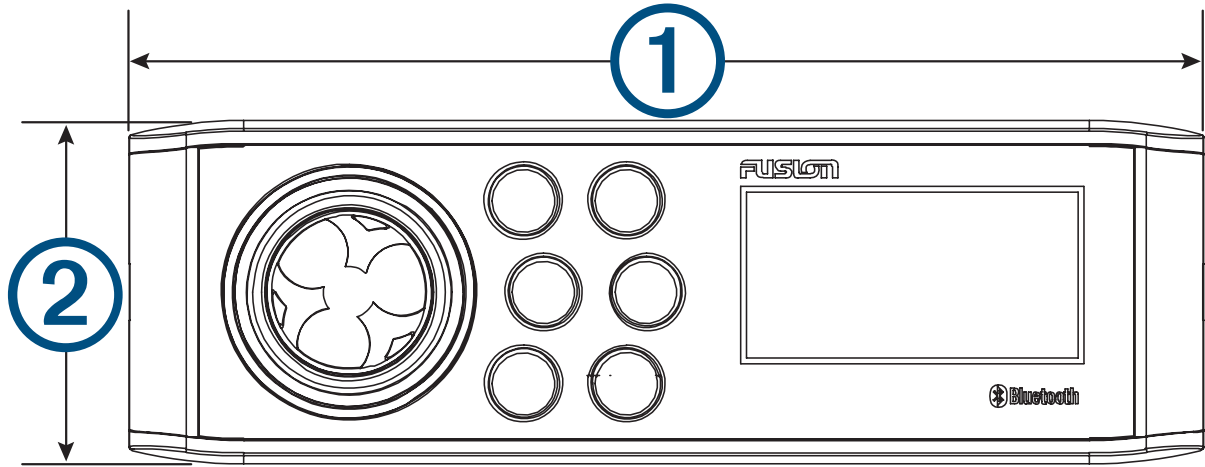

① 188 mm (7.40 in.)

② 60 mm (2.36 in.)

Side Dimensions

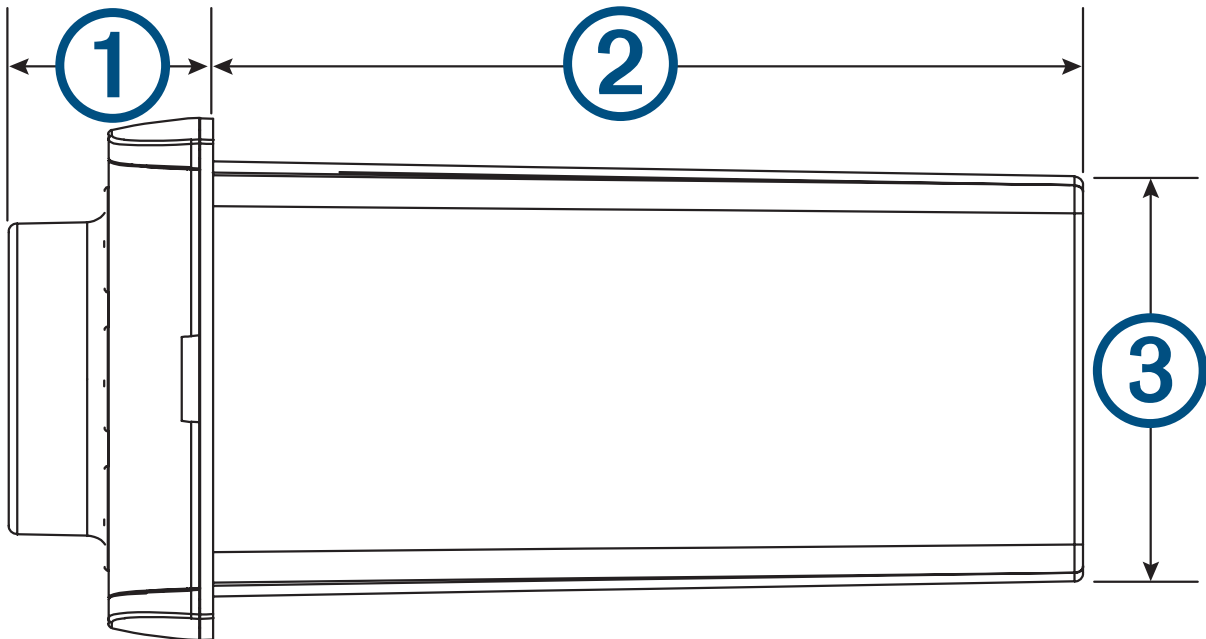

① 23.5 mm (0.93 in.)

② 100 mm (3.94 in.)

③ 50 mm (1.97 in.)

Top Dimensions

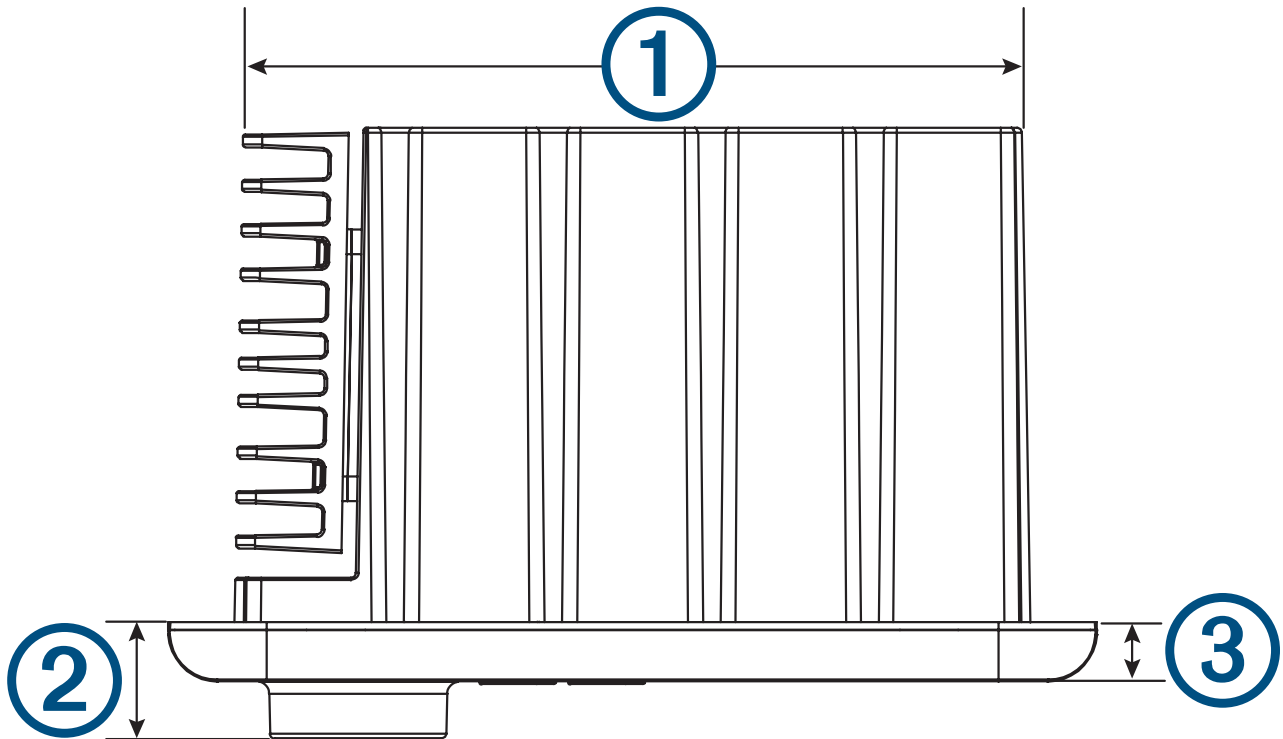

①	161 mm (6.34 in.)
②	23.5 mm (0.93 in.)
③	12 mm (0.47 in.)

Registering Your Fusion Device

Help us better support you by completing our online registration today.

- Go to garmin.com/account/register.
- Keep the original sales receipt, or a photocopy, in a safe place.

Software Updates

For best results, you should update the software in all Fusion devices at the time of installation to ensure compatibility.

You can update the software using a USB flash drive. For software updates and instructions on updating the device using the USB flash drive, go to the device product page at support.garmin.com.

© 2015–2022 Garmin Ltd. or its subsidiaries

Garmin®, the Garmin logo, Fusion®, and the Fusion logo are trademarks of Garmin Ltd. or its subsidiaries, registered in the USA and other countries. These trademarks may not be used without the express permission of Garmin.

Bluetooth® word mark and logos are owned by the Bluetooth SIG, Inc. and any use of such marks by Garmin is under license. NMEA®, NMEA 2000®, and the NMEA 2000 logo are registered trademarks of the National Marine Electronics Association. Other trademarks and trade names are those of their respective owners.

A02834 B02834

