



DUFOUR
YACHTS

OWNER'S MANUAL



YACHT DESIGN CATEGORY: A

IN ACCORDANCE WITH EUROPEAN DIRECTIVE 2013/53/CE

This page intentionally left blank.

This page intentionally left blank.

This page intentionally left blank.

Your agent:

Name

is the DUFOR YACHT representative and will give you all the help you need to solve any difficulties you might have during the launching and masting of your boat, as well as for commissioning and maintenance technical checks. If necessary, he will help you with the administrative process of registering your boat.

As soon as you become the owner, familiarize yourself with the manual supplied with your boat, sign and date the receipt acknowledgments below, and give (or send) the last one to your agent.

Acknowledgment of receipt of the Owner's Manual. Owner's copy to be kept in your Manual

I, the undersigned:

Name
Address

owner of DUFOR 56 no.

confirm that I have received the DUFOR 56 Owner's Manual and accept its being written in the English language.

Dated:

Signature:

Detach along dotted line

✂.....

Owner's Manual receipt acknowledgment to be returned to DUFOR YACHTS

11, Rue Blaise Pascal- 17187 PERIGNY CEDEX- FRANCE

I, the undersigned:

Name
Address

owner of DUFOR 56 no.

confirm that I have received the DUFOR 56 Owner's Manual and accept its being written in the English language.

Dated:

Signature:

This page intentionally left blank.

This page intentionally left blank.

This page intentionally left blank.

CONTENTS

<i>INTRODUCTION</i>	7
<i>I. GENERAL INFORMATION</i>	8
YACHT DESIGN CATEGORY:.....	8
Certification	8
Identification.....	8
Builder's plate.....	9
Degrees of danger	9
<i>II. PRINCIPAL SPECIFICATIONS</i>	11
<i>III. ELECTRICAL SYSTEMS</i>	13
Safety and operating instructions for the electrical system	13
Fitting new equipment.....	13
Batteries	14
Electric windlass	14
220 / 110 volt.....	15
<i>IV. GAS INSTALLATION</i>	16
General information	16
Operation of the LPG system	16
Checking the system	16
Safety warning	17
<i>V. DRAIN & SANITATION SYSTEM</i>	18
Drainage system characteristics (ISO 15083:2003)	18
Pressurized freshwater pump.....	18
Seacocks	19
Operation of the sea	19
Holding tank operation (ISO 8099:2000)	19
<i>VI. FLOODING</i>	20
<i>VII. FIRE PROTECTION</i>	20
Installation	20
Safety instructions	21
<i>VIII. ENGINE</i>	22
General precautions	22
Exhaust gas emission	22
Safety	22
Wintering	23
<i>IX. FUEL INSTALLATION</i>	23
<i>X. HELM SYSTEM</i>	23
Tiller 23	
Emergency tiller	24
<i>XI. SAILING</i>	24
<i>XII. FALL PREVENTION AND MEANS OF GETTING BACK ABOARD</i>	25
<i>XIII. LIGHTNING PROTECTION</i>	26
Maintenance.....	26
Protection of people during a thunderstorm.....	26
<i>XIV. ENVIRONMENTAL PROTECTION & SAFETY</i>	26
<i>XV. SAFETY FACILITIES</i>	27
<i>XVI. HANDLING, TRANSPORTING, HAULOUT</i>	27
<i>XVII. MOORING, ANCHORING, AND TOWING</i>	27
Responsibility	28
<i>XVIII. GUARANTEE, TRANSFER OF OWNERSHIP</i>	29

<i>XIX. DRAWINGS</i>	<i>33</i>
<i>1. Presentation plan</i>	<i>35</i>
<i>2. Accommodation layout</i>	<i>36</i>
<i>3. Deck fittings plan</i>	<i>38</i>
<i>4. Sail plan</i>	<i>40</i>
<i>5. Halyard and sheet operating diagram</i>	<i>42</i>
<i>6. 220V electric panel</i>	<i>44</i>
<i>7. 220V circuit diagram</i>	<i>46</i>
<i>8. 220V circuit diagram</i>	<i>48</i>
<i>9. 220V electrical installation diagram</i>	<i>51</i>
<i>10. Fuse location diagram</i>	<i>53</i>
<i>11. Charging and power system diagram</i>	<i>55</i>
<i>12. 12V electric panel</i>	<i>57</i>
<i>13. Terminal diagram</i>	<i>59</i>
<i>14. 12V electrical installation diagram</i>	<i>61</i>
<i>15. Lighting circuit</i>	<i>63</i>
<i>16. Steering system diagram</i>	<i>66</i>
<i>17. Gas system diagram</i>	<i>68</i>
<i>18. Abandon ship plan</i>	<i>70</i>
<i>19. Freshwater system diagram</i>	<i>72</i>
<i>20. Drain system diagram</i>	<i>74</i>
<i>21. Skin fitting location diagram</i>	<i>76</i>
<i>22. Mechanical installation diagram</i>	<i>78</i>
<i>23. Gas system diagram</i>	<i>80</i>
<i>24. Holding tank installation diagram</i>	<i>82</i>
<i>25. Lifting diagram</i>	<i>84</i>
<i>26. Navigation lights</i>	<i>86</i>

INTRODUCTION

DUFOUR YACHTS is pleased to present you with this Manual which will help you get to know your boat better.

This Manual has been produced to help you use your boat safely and enjoyably. It contains details of the boat, the equipment supplied or fitted, its systems and information about their use. Read it carefully and familiarize yourself with the boat before using it.

This Owner's Manual is not a course in sailing safety or seamanship. If this is your first boat or you are changing to a type of boat you are unfamiliar with, for your convenience and safety, make sure you gain experience in handling and using it before taking command. Your agent, national sailing or cruising federation or yacht club will be happy to give you information about sailing schools or qualified instructors in your area.

Ensure that forecast wind and sea conditions correspond to the design category of your boat, and that you and your crew are capable of handling the boat in these conditions. Even when your boat is suitable for them, the sea and wind conditions corresponding to design categories A, B, and C vary from severe storm for category A to severe conditions for the top end of category C, subject to dangers of abnormal gusts or waves; these are dangerous conditions in which only an experienced, trained crew in good shape, sailing a properly-maintained boat, can sail in a satisfactory manner.

This Owner's Manual is not a detailed maintenance or repair guide. In the event of problems, consult the boatbuilder or their representative. If a maintenance manual is provided, be sure to use it.

Always employ the services of an experienced professional for maintenance, fitting accessories, or modifications. Modifications that could affect the characteristics of the boat must be assessed, performed and documented by qualified personnel. The boatbuilder cannot be held responsible for modifications made without their approval.

In certain countries, a skipper's license or some form of authorization is required, or special rules and regulations are applicable.

Always maintain your boat correctly and make allowances for deterioration due to age or resulting, where applicable, from heavy or unsuitable use. Any boat, however sturdy, can be severely damaged if it is used incorrectly. This is incompatible with safe sailing. Always suit your speed and heading to the prevailing sea conditions.

If your boat is equipped with a life-raft, read its instruction manual carefully. The crew must have all the safety equipment on board (life-jackets, harnesses, etc.), corresponding to the type of boat, weather conditions, etc. In some countries, this equipment is mandatory. The crew must be familiar with the use of all the safety equipment and the emergency safety procedures (man overboard recovery, towing, etc.); training sessions are regularly organized by sailing schools and clubs.

It is recommended that all persons wear appropriate buoyancy aids (life-jackets, personal flotation devices) when on deck. It should be noted that in certain countries, it is compulsory to wear a buoyancy aid (complying with national regulations) at all times.

KEEP THIS MANUAL IN A SAFE PLACE AND PASS IT ON TO THE NEW OWNER IF YOU SELL THE BOAT.

WARNING: Our boats are regularly improved in light of our customers' experiences and research carried out by the shipyard. As a result, the specifications given in this Owner's Manual are not contractually binding and may be changed without notice and without any obligation to update them. This manual is intended to cover as much information as possible, so certain equipment or paragraphs might not apply to your boat. In case of doubt, please refer to the inventory which should have been given to you by your agent when you placed your order.

I. GENERAL INFORMATION

YACHT DESIGN CATEGORY:

Your ExclusiveDUF40UR 56 comes under the **OCEAN-GOING** design category A.

Under conditions of normal use, your boat is designed to sail in waves with a significant height exceeding 4 m and winds of force 8 or above on the Beaufort scale, and to withstand the severest conditions.

This sailing capability is equally dependent on the skills of the crew, their physical capacities, the maintenance of the boat and its equipment.

So always take care before putting to sea.

DUF40UR YACHTS is not able to guarantee perfect functioning of the boat in exceptional sea conditions (violent storms, hurricanes, cyclones, waterspouts, etc.)

SUMMARY OF DESIGN CATEGORIES

Design Categories	Type of sailing	Wind strength (Beaufort)	Wind speed	Effective wave height to be taken into account
A	Ocean-going	Above 8	Up to 28 m/s	Higher than 4 m
B	Open sea	Up to 8	Up to 21m/s	Up to and including 4 m
C	Inshore	Up to 6	Up to 17 m/s	Up to and including 2 m
D	Sheltered waters	Up to 4	Up to 13 m/s	Up to and including 0.5 m

Check weather information before putting to sea: **Take to the sea, don't take risks!**

In port: every day, the Harbor Master's Office posts weather bulletins and forecasts for the next few days

Météo France on 08 36 68 08 08

Navifax - direct on 08 36 70 18 52

VHF: CROSS transmits several bulletins per day, preceded by an announcement on Channel 16.

Certification

DUF40UR YACHTS has chosen the Institut pour la Certification et la Normalisation dans le Nautisme as the notified body for verifying that your boat complies with European directive CE 94/25, in accordance with module B.

Identification

The hull identification number is located on the starboard side of the transom. It contains a series of letters and numbers that begin with FR-DUF...

Builder's plate

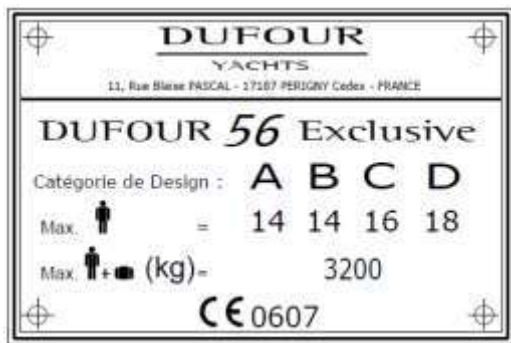

Some of this information is provided on the builder's plate attached to the boat. A full explanation of this information is given below.

Design category = **A**

: Ocean-going (see 1.1)

Maximum number of people:



Category A = **14**

Category B = **14**

Category C = **16**

Category D = **18**

: Recommended by the builder for navigation in sea conditions corresponding to the category for which it was built.

WARNING

Do not exceed the maximum recommended number of people. However many people there are aboard, the total weight of the people and equipment must never exceed the maximum recommended load.

Recommended max. load:



Category A = **3,200 kg**

Category B = **3,200 kg**

Category C = **3,200 kg**

Category D = **3,200 kg**

: recommended by the manufacturer including the weight of all passengers aboard, provisions and personal belongings, in addition to all equipment not included in the boat's light displacement, but excluding the contents of the tanks.

WARNING

When loading the boat, never exceed the recommended maximum load. Always load the boat carefully and distribute the weight in a suitable manner in order to maintain the theoretical trim (approximately horizontal). Avoid placing heavy loads high up.

CE 0607

: CE mark indicating that the boat complies with all the requirements of the Directive. The sequence of digits is the code for the Certifying Body. In this case, it is ICNN (Institut pour la Certification de la Normalisation dans le Nautisme), (see also: Safety Compliance Declaration).

Degrees of danger

DANGER	Indicates an extreme intrinsic risk that presents a high probability of death or permanent injury if proper precautions are not taken.
WARNING	Indicates a risk that presents a high probability of death or permanent injury if proper precautions are not taken.
NOTE	Indicates a reminder about safety-related practices, or points out dangerous practices that could result in personal injury or damage to the boat or its components, or to the environment.

II. PRINCIPAL SPECIFICATIONS

	Model:	DUFOUR 56 Exclusive
	Boatbuilder	Dufour Yachts 11, Rue Blaise Pascal 17187 Périgny cedex FRANCE
	Designer:	Umberto Felci
	Interior design	DUFOUR Design
	YACHT DESIGN CATEGORY:	A
	Notified body no.	CE/0607
	Engine #	
	Primary means of propulsion	Sail
L_{max}	Length overall*	17.15 m
L_H	Hull length*	16.30 m
B_{max}	Maximum beam*	5.04 m
B_H	Hull beam*	5.04 m
H_A	Maximum air draft*	23.60 m
T_{max}	Draft (deep keel)*	2.50 m
	Deep keel weight	4900 kg
	Standard mainsail area (approximate)	72 m ²
	Genoa area (approximate)	69 m ²
	Maximum permissible on-board engine power	150 HP / 110 kW
	Water capacity excl. 50L (approx.) water heater	680 L
	Diesel capacity (approximate)	500 L
	Holding tank	100 L to 235 L depending on option
	Engine battery	140 Ah
	Auxiliary battery (3 standard + 2 optional)	420 Ah + (+280 Ah as an optional extra)
M_{LC}	Light displacement	17600 kg
M_{MO}	Minimum condition displacement	18000 kg
M_L	Maximum loading	4300 kg
	Total weight of liquids (all tanks full)	1195 kg
M_{LDC}	Displacement with maximum load	21900 kg

*The above dimensions comply with ISO 8866, specifically:

L_{max} : maximum length of the vessel including normally fixed parts such as bow rollers, balconies, etc.

L_H : maximum length of the vessel including structural elements that are an integral part of the vessel, and excluding removable parts.

B_{max} : breadth of the vessel measured between the outermost portions and may include detachable parts such as top rails, railings, etc.

B_H : vessel width measured between the outermost fixed portions and excluding all removable parts

H_A : vertical distance between the water plane in the lightship condition and the highest point of the mast structure. (this does not take into account equipment such as lights and antennas that can be attached to the masthead)

T_{max} : the maximum draft is measured at the lowest points of ballast on board the vessel

M_L : The Maximum Load is the sum of the maximum recommended load plus the total mass of the various liquids (drinkable or not)

Nota bene: due to the trim and loading of the boat, is it not usually possible to use the whole of the various tank capacities for fresh water and diesel. It is recommended that you maintain a diesel reserve of 20%.

Specific information

This vessel has been assessed with the help of the Stability Index (STIX), a measure of overall safety with regard to stability, which takes into account the effects of the length of the vessel, its displacement, hull proportions, stability characteristics and its resistance to flooding.

The maximum total load is the sum of the maximum recommended load and the total mass of the various liquids (see ISO 12217-2: 2002)

The second index (AVS, angle of vanishing stability) represents the heel angle at which stability is lost, in degrees.

	Minimum operating condition (M_{MO})	Loaded arrival condition (M_{LA})
STIX	52.2	47
AVS	120.3°	115.5°

III. ELECTRICAL SYSTEMS

Safety and operating instructions for the electrical system

WARNING

Improper use of the DC and/or AC systems may give rise to fire or explosion hazards.
Improper use of the DC and/or AC systems may give rise to fire or explosion hazards.

Always:

- Check the condition of the batteries (charge and electrolyte level) and the charging system before putting to sea.
- Disconnect and remove batteries for wintering.
- Do not let battery voltage drop below 10.5 V during wintering.
- Carry spare bulbs for all navigation lights and interior lighting. Respect power ratings, particularly for navigation lights.
- Check operation of the navigational instruments.
- Check operation of the navigation lights before sailing at night.

You must never:

- Work on a live electrical installation.
- Make any modification to an installation and the relevant diagrams, unless it is carried out by an electrician qualified in marine electrical work.
- Change or modify the breaking capacity of overload protection devices.
- Replace electrical apparatus or equipment with units exceeding the rated capacity without upgrading wiring and protection.
- Leave the boat unattended when the electrical installation is powered, with the exception of the automatic bilge pump and the fire or theft protection circuits when applicable.

If a fuse or circuit-breaker blows repeatedly, you should consult a specialist to determine the cause of the short-circuit.

Fitting new equipment

Since January 1st 1996, electrical equipment is subject to the European “electromagnetic compatibility” directive (Ref 89/336/CEE). It is therefore necessary that any new equipment you may wish to install meets the requirements of this standard and bears the CE mark. Equipment must also be supplied with a compliance certificate and instructions for use.

In the case of 220 or 110V installations, use only double-insulated or earthed equipment. When such equipment is being installed, respect the fitting instructions (conductor size, protection).

To avoid maintenance problems, make sure that any modifications made to the electrical circuit are recorded in writing in the manual.

Batteries

The battery system comprises 3 standard 140 Ah auxiliary batteries (plus 2 optional 140 Ah batteries) and one 140 Ah battery for starting the engine.

Their capacities have been designed to handle the power requirements of the on-board accessories. To avoid any problems, it is necessary to keep a close eye on the maintenance and correct charging of the batteries.

ATTENTION !

- When installing new electrical appliances, take care that the total consumption of these appliances remains within the capacity of your batteries.
- Always disconnect the negative (-) battery terminal before the positive (+) terminal.
- Never allow a conductive object (tools, etc.) to bridge across the two battery terminals.
- When handling batteries, keep them horizontal to avoid spillage of electrolyte. Wear gloves and protective clothing that will prevent any risk of contact with electrolyte in the event of a leak.
- If any electrolyte comes in contact with skin, eyes, etc., rinse the affected part of the body thoroughly and consult a doctor.

Electric windlass

ATTENTION !

It is essential to run the engine with the throttle slightly open when using the electric windlass.

DANGER !

The on-board 220 V installation is protected by a circuit breaker and fitted with a residual current device. The wiring of additional 220 V on-board accessories must be carried out by professionals, and the master circuit-breaker uprated if necessary.

- Do not modify the vessel's electrical installation nor the relevant diagrams. Installation, modification and maintenance should be carried out by a qualified marine electrician. Have the system checked every 2 years
- Disconnect the boat's power supply when system is not in use.
- Connect the metal cases or housings of installed electrical equipment to the ship's protective conductor (green or green / yellow wire).
- Use double-insulated or earthed electrical appliances.
- If possible, the differential circuit-breaker should be tested monthly.

ATTENTION!

When the boat is moored at the quayside, set the isolator to the 'off' position.

DANGER !

Your boat is not supplied with a shore/boat supply cable or a male plug for the shore outlet. The cable must be suitable for outdoor use. Its cross-sectional area must be adjusted according to its length and the rating of the main circuit-breaker (see electrical diagram). The plug must be suitable for the socket on the shore (if necessary, seek the advice of a professional). It should be as close as possible to the **IP 67 / IEC529**

WARNING: To reduce the risk of electric shock and fire.

- Switch off the shore supply at the on-board isolator before connecting or disconnecting the shore/boat supply cable.
- Connect the shore/boat supply cable at the boat end before connecting it to the shore outlet
- Disconnect the shore/boat supply cable at the shore outlet before disconnecting it at the boat end
- Close the shore outlet cover properly

You must never:

- Do not make modifications to the shore supply cable; use only compatible connectors.
- Go swimming close to a boat connected to a shore supply socket: danger of electrocution!

Location of the 220 V master circuit-breaker: port side cockpit locker.

Have the system checked every 2 years.

During haul-out maintenance, set to the 'on' position in order to have **earth [grounding] protection** via the shore socket.

WARNING

Never let the end of a ship/shore supply cable dangle into the water. It may create an electrical field that could injure or kill nearby swimmers.

IV. GAS INSTALLATION

General information

- Operating pressure 30 mbar (see indications on the label in the gas locker and on the regulator valve).
- Ventilation openings to be used for the evacuation of exhaust gases: hatch above the cooker and the companionway.
- Do not obstruct quick access to the elements of the gas installation (cylinder locker, shut-off valve).
- Regularly inspect the hoses (at least once a year) and change them if you observe any deterioration, if the expiry date has been exceeded or within five years of the date printed on the hose.
- The cylinder shut-off valves should be closed and disconnected. Protection hatches, covers and caps should be kept in place. Reserve cylinders should be stored in the LPG cylinder housing or lockers with a ventilation circuit leading towards the exterior, or stored at the exterior of the vessel, protected from weather and mechanical damage and allowing any gas leakage to evacuate towards the exterior.
- LPG cylinder lockers must not be used for the storage of any other material.
- Ensure that the gas cylinder and regulator are in accordance with the requirements of the cooker (flow rate, pressure, type of gas) and with the regulations in force in the country where it is being used.

Operation of the LPG system

- Supply system shut-off valves and cylinder valves should be kept closed when the appliances are not in use, before filling and immediately in case of emergency.
- Appliance shut-off valves must be closed before opening cylinder valves.

WARNING

- Fuel-burning naked-flame appliances use up the oxygen in the cabin and release combustion products inside the vessel. Proper ventilation is necessary: Open the deck hatch or porthole located nearby as well as the companionway when the devices are in operation.

- The cooker is mounted on gimbals and can therefore be used when the vessel is under way. Nevertheless, limit use when wide angles of roll or heel are likely.

Checking the system

- The LPG system should be checked for leakage before each use in the following way:
- Close the shut-off valve of the appliance, open the valve of the LPG cylinder, allow the pressure indicated on the pressure gauge to stabilize, close the valve of the LPG cylinder, observe the pressure indicated by the pressure gauge located near the cylinder for three minutes. The pressure indicated by the pressure gauge should remain constant if there is no leakage in the system.
- Information: the pressure gauge does not indicate the quantity of liquid LPG remaining in the cylinder, but only its vapor pressure, which is a constant at a given temperature.

- If an LPG leak is detected or suspected, take the following steps immediately:
- Cut off the supply at the main supply valve(s).
- Extinguish any naked flames and other sources of combustion (heating appliances, cooking appliances, lights, etc.)
- Do not operate any electrical switch.
- Evacuate the area if possible

WARNING

- Do not use any installation with a leak before it has been inspected and repaired by a competent person.

DANGER !

Never use a naked flame to search for leaks.

- Note: the above tests do not replace periodic inspection that is recommended to be carried out by a professional.

Safety warning

WARNING

- Never leave the vessel unattended when gas appliances are on
- refrain from smoking or using a naked flame while LPG cylinders are being changed. Close the valve on the empty cylinder before disconnecting it to change it. The cylinder compartment should be well ventilated when replacing a cylinder.
- Do not use the cooker/oven as a heating appliance.
- If a leak is detected, close the main LPG supply valve and do not use devices running on LPG.
- After the boat has been shut up, never smoke when going below, and ensure that there is no smell of gas.
- Do not modify the LPG system of the vessel. Installation, the modifications and maintenance must be carried out by a competent person. Have the system inspected at regular intervals or at the intervals fixed by national requirements.

ATTENTION!

- Certain precautions must be taken to avoid any contact with naked flames or other hot areas.
- Do not use solutions containing ammonia during manual tests for leaks

V. DRAIN & SANITATION SYSTEM

Drainage system characteristics (ISO 15083:2003)

Pump type	Theoretical flow rate
Manual	38 L @ 45 strokes/minute
12V Electrical 12V Automatic	3,900 L/h 2,820 L/h

Read the operating and maintenance instructions for your boat's bilge pump carefully.

WARNING

The bilge pump system is not designed to handle water entering as a result of holing of the hull. It is intended to remove water coming from spray, leaks from seacocks or other moderate leaks.

ATTENTION!

- The level of water in the bilge must be kept to a minimum.
- Make sure that bilge pumps are in working order before putting to sea.
- Regularly remove any debris that might obstruct the sump well and the pump intake points or strainers.

If the watertight bulkheads that isolate the fore- and after-peaks are fitted with valves, they should normally be kept closed and should only be opened to drain the water into the main bilge.

- Know where to find each hand pump and its handle.
- Locate the switch for the electric bilge pump on the electrical panel.

Pressurized freshwater pump

Freshwater is supplied to the sink and washbasins by an electric pump. A filter is installed upstream of the pump, and must be cleaned regularly.

Never allow the pump to run if the tank is empty. Refill the tank before using the water supply again.

The tanks can be sterilized using Clonazone® tablets (available from pharmacies). Every year, remove the inspection covers and clean them by filling with water containing a bactericidal detergent; leave it to act for a few hours, then rinse two or three times. During wintering, completely fill the tanks to avoid the development of algae or bacteria. If there is a risk of freezing, empty the tanks; never use anti-freeze.

Hot water is produced by a water-heater connected to the engine cooling circuit and the shore electric supply.

After the water-heater has been emptied, make sure that the element is covered before power is re-applied.

Seacocks

Seacocks are of the ¼-turn type:

- OPEN position: handle in line with seacock body,
- CLOSED position: handle perpendicular to the seacock body.

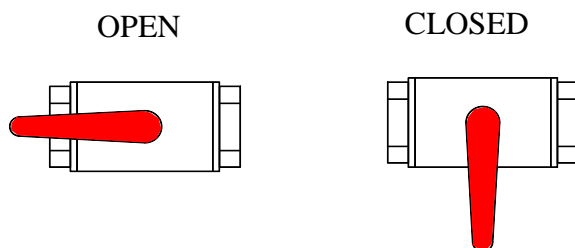

ATTENTION!

- Never interfere with the tightening of the seacocks to the hull. In the event of a leak, consult a professional.
- In bad weather or when leaving your boat, close all the sanitation system seacocks.
- Keep seacocks closed when not in use and remember to manipulate them regularly to keep them from seizing. A seacock that is not used for a long period can jam.
- During wintering, clean and rinse the seacocks and skin-fittings. Inspect brass fittings; slight surface corrosion is normal.
- In the event of more serious corrosion, consult your agent.

Operation of the sea

- Open the sea water inlet cock.
 - Open the bowl emptying seacock.
 - Set the lever to the “FLUSH” position.
 - Operate the pump.
 - To empty the bowl and avoid any water slopping when heeling, set the lever to the “DRY BOWL” position.
 - Operate the pump until the bowl is dry.
 - Repeat these flushing / emptying operations as many times as is necessary to ensure complete emptying of the pipes.
- When toilets are not being used, set the lever to the «DRY BOWL» position, or the «CLEF» position for certain models.
- **Close seacocks after use, as the toilet is below the waterline.**
 - Change the toilet seals regularly.

Holding tank operation (ISO 8099:2000)

ATTENTION!

Where a holding tank is fitted, take care to lock the discharge valve, to avoid any accidental discharge during wintering.

- The (50L) sewage tank operates using the manual toilet pump.
 - The contents of the toilet pan are discharged straight into the holding tank.
 - Periodically check that the vent is working properly.
 - A deck plate is provided for emptying the tank.
 - The discharge valve can be sealed in the closed position using a padlock.
 - Once a season, arrange to clean out the tank using a biodegradable disinfectant chemical.
- Leave the system empty if the vessel is to be left in below-freezing temperatures

VI. FLOODING

To avoid the risk of flooding the boat:

- Check that portholes, deck hatches, and any other openings that may cause flooding, are closed before putting to sea.
- While under way, close all seacocks when they are not in use, except for the engine water intake.
- Do not exceed the maximum recommended loading.
- The level of water in the bilges must be kept to a minimum.
- Avoid adding weight in high places so as not to affect the stability.

Periodically check:

- Skin fittings, seacocks and pipes are watertight.
- Proper emptying of the cockpit drains.
- Stern glands or sail-drive seals for watertightness.

WARNING

Cockpit locker lids must be fastened shut before putting to sea. This is particularly important for those lockers that represent a major flooding risk.

VII. FIRE PROTECTION

Installation

Since fire extinguishers are subject to national regulations, they are not supplied with the boat.

However, when in use, this boat must be fitted with portable extinguishers with the following capacities, installed in the following locations (see drawing in Appendix 17):

- No. 1 – cockpit locker, within reach of the helmsman - capacity 1 kg - 5A34B
- No. 2 – saloon/mast foot - extinguishing capacity 1 kg - 5A34B
- No. 3 – galley unit - extinguishing capacity 1 kg - 5A34B
- No. 4 – skipper's cabin on option

If you decide to install a carbon dioxide (CO₂) extinguisher, be aware that it may only be fitted in accommodation areas that contain powered electrical equipment (e.g. electric motors, battery compartments, electrical panels) or flammable liquids (e.g. galley).

Only compatible replacement parts must be used in the fire protection system. They must bear the same markings and be technically equivalent.

In addition, a fire blanket should be stored in the saloon banquette, close to the galley. This can be very useful, particularly in the event of an oil-based pan fire: saloon banquette.

Similarly, for safety on deck, a fire bucket equipped with a lanyard must be stored in an immediately accessible locker.

If non-combustible materials are stored in the engine compartment, they must be secured to avoid the risk of falling onto the machinery and must not obstruct access to the engine compartment or its exit.

WARNING

If a CO₂ extinguisher is fitted, the following information must be displayed close to its location:

“This extinguisher contains CO₂ - use only on electrical or cooker fires. To avoid suffocation after discharging, leave the area immediately. Ventilate before re-entering.”»

Do not open the engine compartment immediately after putting out a fire to avoid the release of toxic smoke or spraying of burning materials (oil, water)."

Safety instructions

ATTENTION !

It is the responsibility of the owner / skipper to:

- Have fire-fighting equipment checked in accordance with the stipulations of the builder and the regulations in your country.
- Replace fire-fighting equipment if it has expired or been discharged, with extinguishers of equal or greater capacity.
- Show members of the crew:
 - The location and operation of fire-fighting equipment.
 - the location of the engine compartment discharge hole
- Ensure that fire-fighting equipment is readily accessible whenever the boat is occupied.
- Always keep the bilges clean and check that there is no fuel vapor or gas leak.
- Point out the escape routes.

You must never:

- Obstruct gangways leading to emergency exits (deck hatches).
- Obstruct safety controls (gas valves, fuel valves, electrical switches).
- Obstruct fire extinguisher stowages.
- Leave the boat unattended with a cooker or heater on.
- Use a gas lamp in the boat.
- Fill a fuel tank or change a gas cylinder while the engine is running, or the cooker or heater are on.
- Smoke while handling fuel or gas.
- Place free-hanging curtains near the cooker or any other appliance which has an open flame.
- Store flammable substances in the engine compartment.
- Modify, or allow any non-qualified person to modify, any of the boat's installations (especially electrical, fuel, or gas).

VIII. ENGINE

Regular maintenance must be carried out in accordance with the engine manufacturer's recommendations. Read the engine operating instructions that come with the boat carefully. Do not hesitate to consult your agent or a qualified professional. In particular, follow the instructions for wintering.

General precautions

ATTENTION !

Do not use the sail and engine if the heel angle is more than 10°.

Any engine change must respect the capacities of the boat and be performed by an engineer specializing in marine mechanics.

After the first launching and tensioning of rigging, check the alignment of the propeller shaft or the sail-drive flange ring.

- Make sure that the ventilation openings (vents, engine air intake grating) are completely clear.
- Make sure that the water intake seacock for the cooling system is open, and that water is indeed coming out of the engine exhaust.
- Boats fitted with rotating seal stern gland: bleed the air from the gland after each launch.
- Prevent any deterioration to the fuel supply circuits.
- Do not store any equipment containing gasoline (outboard engine, tank, gasoline generator, etc.) in compartments that are not designed for this purpose.

Put the throttle in neutral before starting the engine to keep the boat from moving and/or the propeller from turning.

On subsequent launches, a brief check of propeller fixing can be made. Incorrect operation of the folding propeller will lead to vibration.

Regularly check the condition of the anodes and ensure that they are suitable for the boat's environment (fresh water, salt water). Change the anodes every year. The 3 anodes have an average life of 1–2 years.

These anodes are made of zinc. You must not use magnesium ones. Impressed current cathodic protection systems should not be used.

If the anodes are not eroded, you need to check:

- that they have not been painted over,
- that they are correctly fixed and in contact with the hull,
- and that they are indeed made of zinc.

Exhaust gas emission

DANGER!

Internal combustion engines produce carbon monoxide. Prolonged exposure to exhaust gases can have serious consequences, and may even cause death.

Safety

DANGER!

In order to avoid all risk of serious injury from the propeller, the engine must not be started when there are people swimming near the boat.

Whenever possible, the engine must be stopped for any engine maintenance or checking operations. Otherwise, special attention must be paid to moving parts (propeller shafts, belts, etc.) in order to avoid any risk of injury.

Wintering

Read the operating and maintenance instructions for the engine that goes with your boat and the instructions for wintering carefully.

In the absence of other instructions, proceed as follows:

- Close the engine water intake seacock,
- Disconnect the pipe from the engine water intake seacock,
- Drain the sea-water circuit,
- Place the pipe into a drum of -25° anti-freeze coolant,
- Run the engine until the fluid comes out of the exhaust,
- At the end of this operation, re-connect the pipe to the seacock,
- Attach a notice to the electrical panel and the battery isolator stating that the engine water intake seacock is closed.

IX. FUEL INSTALLATION

In the event of deterioration, flexible fuel pipes must be replaced by pipes bearing the same markings. Do the same for all fuel lines.

ATTENTION!

- Depending on the trim and loading of your boat, not all of the nominal fuel capacity may be used. Always maintain a 20% reserve for safety.
- Avoid contact between flammable materials and hot parts of the engine.
- Clean up any overflow of fuel that may occur when filling the tanks.

You must never:

- Store flammable materials in unventilated spaces.
- Smoke while filling tanks.
- Obstruct ventilation openings (vents, engine air intake grating): Make sure they are completely clear.
- Modify the installation, unless work is done by a qualified technician.

X. HELM SYSTEM

The steering system plays a vital role in the safety and comfort of your boat.

Tiller

The DUF0UR 56 is fitted with a dual wheel with a system of rudder cables and chains as well as with an emergency tiller.

Checks to be carried out periodically: Check the play in the various elements (rudder stock/bearings, tension and wear in mechanical components) and grease the sprocket and chain if necessary.

In the event of any doubt or problem, consult your agent.

Emergency tiller

ATTENTION !

- The **Dufour 560** is fitted with an emergency tiller which must be kept readily accessible; we advise stowing it in one of the nacelle cockpit lockers.
- It is designed only for sailing at reduced speed in the event of damage to the helm.

To use it:

- Unscrew the deck-plate to reveal the head of the rudder stock
- Fit the tiller onto the head of the rudder stock.

XI. SAILING

WARNING

In all situations, adapt the speed of your boat to the surrounding conditions and always maintain a safety margin. Pay particular attention to:

- Sea conditions, currents and the strength of the wind
- Movement of other boats
- Maneuvers in port
- When passing through mooring areas.
- Obey the rules of right of way as set out in the Rules of the Road as established by COLREG
- Ensure that you always have enough room for stopping or for any necessary maneuvers to avoid a collision
- Respect speed limits.
- Out of courtesy and for the safety of other boats, exercise care and attention to minimize your boat's wake near other boats
- Movable items must be carefully secured when at sea

WARNING

- You must fit your boat with grab lines. Anchor-points are provided on the deck. Please refer to the deck fittings plan for your boat.
- The stability of your boat has been designed taking into account the boat's weight specification for light displacement, the standard equipment on board and the manufacturer's catalogue options.

Any alteration to on-board weight distribution (for example: adding a radar, changing the engine, etc.) can affect the stability, trim and performance of your boat.

Breaking waves represent a significant threat to stability.

Towing another boat produces significant extra loading, which will have an adverse effect on the stability of your boat.

- **You must never:**
Lift heavy weights using the boom.

XII. FALL PREVENTION AND MEANS OF GETTING BACK ABOARD

While underway, it is recommended to move about on deck only in areas provided for this purpose. These areas (gangways, cockpit, roof, side seats, etc.) are provided with non-skid coatings or teak (depending on option selected) making it safe to move about.

On the DUFOR 56, it is possible to move safely around the entire deck area included within the guardlines. Pathways are provided for on glazed surfaces where necessary and are indicated by anti-slip surfaces.

Note that when open, the aft platform is not considered as a secure area. It should be kept closed when under way.

Depending on sea conditions, wind and the degree of heel, it is also recommended that you use the harness by attaching it to the various attachment points mentioned in the deck fittings plan. When the vessel is under way, use the various handholds available whenever possible, such as the grab rails on the helm console and cockpit table, lateral grab rails on the coachroof, shrouds, etc.

The DUFOR 56 is equipped with a swim ladder built into the stern door. In this case, lower the stern door by releasing the retrieval cord then disengage the ladder from its housing and unfold it into position.

A safety ladder is also provided in case of emergency. It is located on the starboard stern rail, and can be deployed from the water. Ensure that you are familiar with the system and can operate it under any circumstances, notably when the vessel is under way.

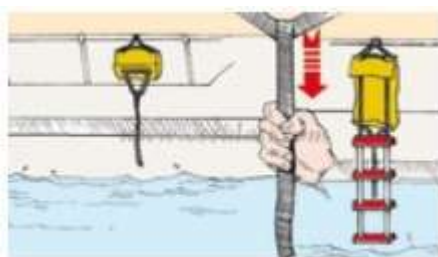

XIII. LIGHTNING PROTECTION

Your boat is protected against lightning. The rigging is electrically earthed (grounded). Nonetheless, for your safety, it is necessary to respect certain precautions.

Maintenance

If the vessel has been hit by lightning:

- The protection installation must be inspected to detect physical damage and check the integrity of the device, as well as the continuity of the earthing.

- The compasses, electrical and electronic devices must be examined in order to ascertain if damage or calibration changes have occurred.

Protection of people during a thunderstorm

WARNING

During a thunderstorm, it is recommended that you comply with the following instructions:

- People should stay below as much as possible.
- People should stay out of the water and not let their arms or legs hang into the water.
- While maintaining satisfactory control of the vessel and its course, persons aboard should not touch any parts connected to a lightning protection system, and especially not in such a way as to form a link between these parts.
- People should avoid touching any metallic parts of the rigging, spars, deck fittings and life-lines.

XIV. ENVIRONMENTAL PROTECTION & SAFETY

We recommend that you find out about local regulations concerning the environment and obey international regulations against pollution in the marine environment (MARPOL), together with the codes of good practice.

Do not discharge the toilets or the contents of the holding tanks near coasts or in prohibited areas; use port or marina pumping systems for emptying the holding tanks before leaving port.

ATTENTION!

- Most cleaning products, engine oils and fuels are likely to impact the environment, so they should be discharged in authorized locations (check with the Harbor Master's office).
- Do not run the bilge pump when oil or fuel is present in the engine compartment, as these chemicals must be discharged in authorized locations.
- Certain products can also pose a risk to your safety and that of others, which is why it is important to read and follow the instructions for use.
- Chemicals must be labeled and stored in an appropriate place on the boat.

XV. SAFETY FACILITIES

There is no harmonization of mandatory safety equipment across the European Community. You should find out about current national requirements for CE-marked vessels.

In France, the skipper is responsible for ensuring that recreational craft bearing the CE mark carry the mandatory handling and safety equipment stipulated for the relevant sailing category.

Your boat is provided with a stowage position for a life-raft, read the life-raft instruction manual carefully. The crew should be familiarized with the use of all safety equipment (harnesses, flare, life-raft, etc...). Training sessions are organized regularly by sailing schools and clubs.

XVI. HANDLING, TRANSPORTING, HAULOUT

When hauling out, ensure that the slings are correctly positioned and that they do not bear on the propeller, propeller shaft or a fragile sensor.

Lifting frames must be wide enough, or fitted with spreaders, so as to avoid applying excessive lateral pressure on the rubbing strakes.

Avoid allowing slings to foul the life-lines. During transport or haulout, the keel should be in proper contact with its support and should be taking most of the boat's weight.

Cradle pads must be positioned against structural elements in order to exert only the pressure necessary for the boat to be properly balanced.

Take advantage of the opportunity provided by haul-outs to inspect the propeller, rudder, skin fittings, and transducers.

ATTENTION !

The aft lifting point is located near the propeller shaft.

XVII. MOORING, ANCHORING, AND TOWING

ATTENTION! (ISO 15084:2003)

- The anchor points for anchoring and/or towing are the 2 fore cleats, which have a breaking strain of approximately 9000 kg. The rear cleats can also be used for mooring. They have a breaking strain of approximately 6000 kg.
- The breaking strain of lines/chains should generally not exceed 80% of the breaking strain of the anchor points, i.e. in this case a maximum 12 mm galvanized chain and 22 mm polypropylene anchor rope.
- Tow or be towed at a low speed. Never exceed the hull speed of a displacement boat in tow.
- The tow line should always be made fast in such a way that it can be released when under load.

Responsibility

It is the owner/operator's responsibility to ensure that the mooring lines, towing cables, anchor chains and lines, together with the anchors, are suitable for the boat's intended use, i.e. that the lines or chains do not exceed 80% of the breaking strain of the corresponding anchor point.

Furthermore, the owner must take into account the actions required when making fast a tow cable.

XVIII. GUARANTEE, TRANSFER OF OWNERSHIP

A) CONTRACTUAL GUARANTEES

Note: This guarantee does not apply to boats being used for commercial purposes (it being specified that any hiring or chartering activity falls into this category) nor to sailing boats taking part in competitions, which may be covered by special guarantees.

8 - Guarantees

a) New boats and equipment:

8.1.1 – For both Commercial Purchasers and private consumers domiciled outside the territory of the European Union, the Seller grants the statutory warranties as defined in the context of the sale of vessels by Articles 1641 and 1648 of the French Civil Code and in the context of a marine construction contract by Articles 7 and 8 of Law no. 67.5 dated 3rd January 1967 pertaining to vessels.

8.1.2 – For Purchasers domiciled within the territory of the European Union and taking out the contract as private consumers, the Seller is required to furnish the guarantees as defined in the context of a boat sales contract by Articles 7 and 8 of the Act dated 07/01/1967 pertaining to vessels, and in the context of the Order (2005-136) dated 17/02/2005 and incorporated into the French Consumer Code. Independently of this guarantee, the Seller remains liable for discrepancies between the goods and the contract and for redhibitory defects under the conditions provided for under Articles 1641 to 1649 of the French Civil Code (see. 8.1.1).

8.2 – Visible defects: acceptance by the Purchaser releases the Seller from their obligation in respect of discrepancies and visible defects.

8.3 - Contractual guarantee:

Except for guarantee or penalty clauses expressly agreed at the time of accepting the order, the Seller's guarantee is granted under the following conditions:

- The Purchaser benefits from a contractual guarantee running for two years from the date of acceptance of the vessel, as noted on the acceptance report.
- This is limited to the replacement or free repair, at the yacht-builder's discretion, of any parts acknowledged as being defective by the yacht-builder's technical services; this being without any other compensation of any kind.
- For components and accessories visibly bearing the mark of another supplier, the guarantee is limited to the guarantee offered by that supplier.
- It is stipulated that any handling, transport, parking,

or conveying costs incurred in carrying out these operations remain the sole liability of the buyer/user, unless DUFOR YACHTS yacht-builders offer to waive them in full or in part.

- The boat-builder's warranty excludes:
 - the cost of transporting the boat or any parts, and any consequences thereof, together with expenses and/or any damage arising out of the inability to use the boat and/or the equipment;
 - normal wear and tear;
 - cracking, crazing, or discoloration of the gelcoat;
 - damaging resulting from:
 - fortuitous events or cases of force majeure;
 - conversions and modifications, or repairs, even partial, carried out other than in workshops authorized by the maker;
 - failure to observe the maintenance recommendations set out in the Owner's Manual supplied with the boat;
 - improper use, in particular through negligence, carelessness, abuse, or abnormal usage;
 - participating in competitions;
 - failure to take necessary protective measures;
 - unsuitable storage or transport conditions.

In order to benefit from the yacht-builder's contractual guarantee, each time they make a claim under it, the buyer/user will be required to submit the boat delivery certificate and the guarantee document, duly completed, and, on pain of rendering it void, must notify their dealer/vendor of the fault or defect in writing, in detail and with justifications, within 15 days of its being discovered.

8.4 – the guarantee covers usage at sea in wind and sea conditions acceptable for safety and in accordance with the vessel's approval category. Under these conditions, it cannot under any circumstances cover events arising during or resulting from collisions, groundings, breaking seas, tidal waves, cyclones, severe storms, and all other exceptional events and/or events arising out of an error of seamanship.

8.5 – Loss of or damage to products occurring after handover do not release the Purchaser from their obligation to pay the price.

b) Second-hand boats and equipment:

The order form specifies if the boat or equipment is second-hand. The Purchaser benefits from a contractual guarantee, covering hull and engine only, running for one year from the date of acceptance of the vessel or goods, as noted on the acceptance report.

c) In addition to the contractual guarantee detailed above, the Seller remains liable for discrepancies in the goods and for latent defects under the conditions provided for under Articles 1641 to 1649 of the French

Civil Code and the provisions of the Order dated 17/2/2005, where applicable.

B) COMMON GUARANTEE CONDITIONS

Any claim under these guarantee conditions must be made formally to DUFOR YACHTS in writing as soon as the defect is discovered, and within eight (8) days for claims under the contractual guarantee. Any claim will also be required to quote the serial number of the boat concerned, and where applicable the part number(s) of the part(s) involved in the guarantee claim.

Furthermore, the request must indicate the exact circumstances under which the problem occurred.

In order to investigate the request, DUFOR YACHTS Immobilization following problems encountered and/or replacement and/or repair work, whatever the duration, does not create entitlement to compensation.

The owner shall under all circumstances remain liable for parking fees, customs dues and other ancillary expenses.

All repairs and/or replacements will be carried out by an authorized DUFOR YACHTS agent or by a professional duly acting under the Boatbuilder's instructions. If the nature of the repairs requires the guarantee repair work to be carried out in DUFOR YACHTS workshops or in any location other than the place where the Product is located, the owner will be liable for the cost of both outward and return transport to the Yacht builder.

In the event that the boat needs to be taken out of the water, haul-out and re-launching costs will be at the owner's expense.

C) TRANSFER OF GUARANTEES

The guarantees are afforded to the first purchaser of the boat involved. They are only transferable with DUFOR YACHTS' prior written agreement.

An ownership transfer note is supplied with the Product documents. This must be sent to DUFOR YACHTS within thirty (30) days of the transfer.

This note must bear the names, addresses and telephone numbers of the old owner and the Purchaser, the date of sale, and the Product's hull number.

Upon reception, DUFOR YACHTS will confirm the guarantee expiry dates and specify whether the unit has received the annual inspection that gives entitlement to the continuation of the contractual guarantees.

D) STATUTORY DECLARATIONS

Article L.211-4 of the Consumer Code:

"The seller is required to supply goods that conform to the contract and to assume liability for discrepancies existing at the moment of handover. He shall likewise be liable for discrepancies arising out of

the packaging, assembly instructions, or installation when he is liable for this under the contract or it has been carried out under his responsibility."

Article L. 211-5 of the Consumer Code:

"In order to conform to the contract, the goods must:

1) Be suitable for the normal expected use for similar types of goods and, where applicable:

- correspond to the description given by the seller and possess the qualities the latter has presented to the buyer in the form of a sample or model;

- present the qualities that a buyer may reasonably expect with regard to public declarations made by the seller, by the producer or by his representative, particularly in advertising material or labeling;

2) Either present the characteristics defined by joint agreement between the parties, or be suitable for any special usage sought by the buyer that the seller has been made aware of and has agreed to."»»

Article L.211-12 of the Consumer Code:

"Actions arising out of a discrepancy lapse after two years from the date the goods are handed over."»»

Article 1641 of the Civil Code:

"The seller is obliged to guarantee against latent defects in the article sold which render it unfit for its intended use, or which adversely affect this use to such an extent that the buyer would not have purchased it, or would have only paid a lower price, if he had known about them."»»

Article 1648, Para. 1 of the Civil Code:

"Actions arising out of redhibitory defects must be brought by the purchaser within two years of discovery of the defect."»»



DUFOUR

YACHTS

TRANSFER OF OWNERSHIP CERTIFICATE TRANSFER OF OWNERSHIP

Boat model:

Hull

From Mr. Ms: Address

.....

ZIP City Tel:.....

Date

BEING

Mr./Ms.: **Address:**

.....

ZIP City Tel:.....

Date

Signed at date

Seller Buyer

Signed for DUFOUR YACHTS on: ..

Return the copy within 15 days of completing the transaction to:

Return the copy within 15 days after the transaction to:

SAV DUFOUR YACHTS
11 rue Blaise Pascal
17187 PERIGNY CEDEX FRANCE

This page intentionally left blank.

This page intentionally left blank.

This page intentionally left blank.

XIX. DRAWINGS

INTRODUCTION	7
I. GENERAL INFORMATION	8
II. PRINCIPAL SPECIFICATIONS	11
III. ELECTRICAL SYSTEMS	13
IV. GAS INSTALLATION	16
V. DRAIN & SANITATION SYSTEM	18
VI. FLOODING	20
VII. FIRE PROTECTION	20
VIII. ENGINE.....	22
IX. FUEL INSTALLATION	23
X. HELM SYSTEM	23
XI. SAILING	24
XII. FALL PREVENTION AND MEANS OF GETTING BACK ABOARD	25
XIII. LIGHTNING PROTECTION	26
XIV. ENVIRONMENTAL PROTECTION & SAFETY	26
XV. SAFETY FACILITIES	27
XVI. HANDLING, TRANSPORTING, HAULOUT	27
XVII. MOORING, ANCHORING, AND TOWING	27
XVIII. GUARANTEE, TRANSFER OF OWNERSHIP	29
XIX. DRAWINGS	33
1. Presentation plan	35
2. Accommodation layout.....	36
3. Deck fittings plan	38
4. Sail plan	40
5. Halyard and sheet operating diagram	42
6. 220V electric panel	44
7. 220V circuit diagram	46
8. 220V circuit diagram	48
9. 220V electrical installation diagram	51
10. Fuse location diagram	53
11. Charging and power system diagram	55
12. 12V electric panel	57
13. Terminal diagram	59
14. 12V electrical installation diagram	61
15. Lighting circuit.....	63
16. Steering system diagram	66
17. Gas system diagram	68
18. Abandon ship plan	70

19.	<i>Freshwater system diagram</i>	72
20.	<i>Drain system diagram</i>	74
21.	<i>Skin fitting location diagram</i>	76
22.	<i>Mechanical installation diagram</i>	78
23.	<i>Gas system diagram</i>	80
24.	<i>Holding tank installation diagram</i>	82
25.	<i>Lifting diagram</i>	84
26.	<i>Navigation lights</i>	86

1. Presentation plan

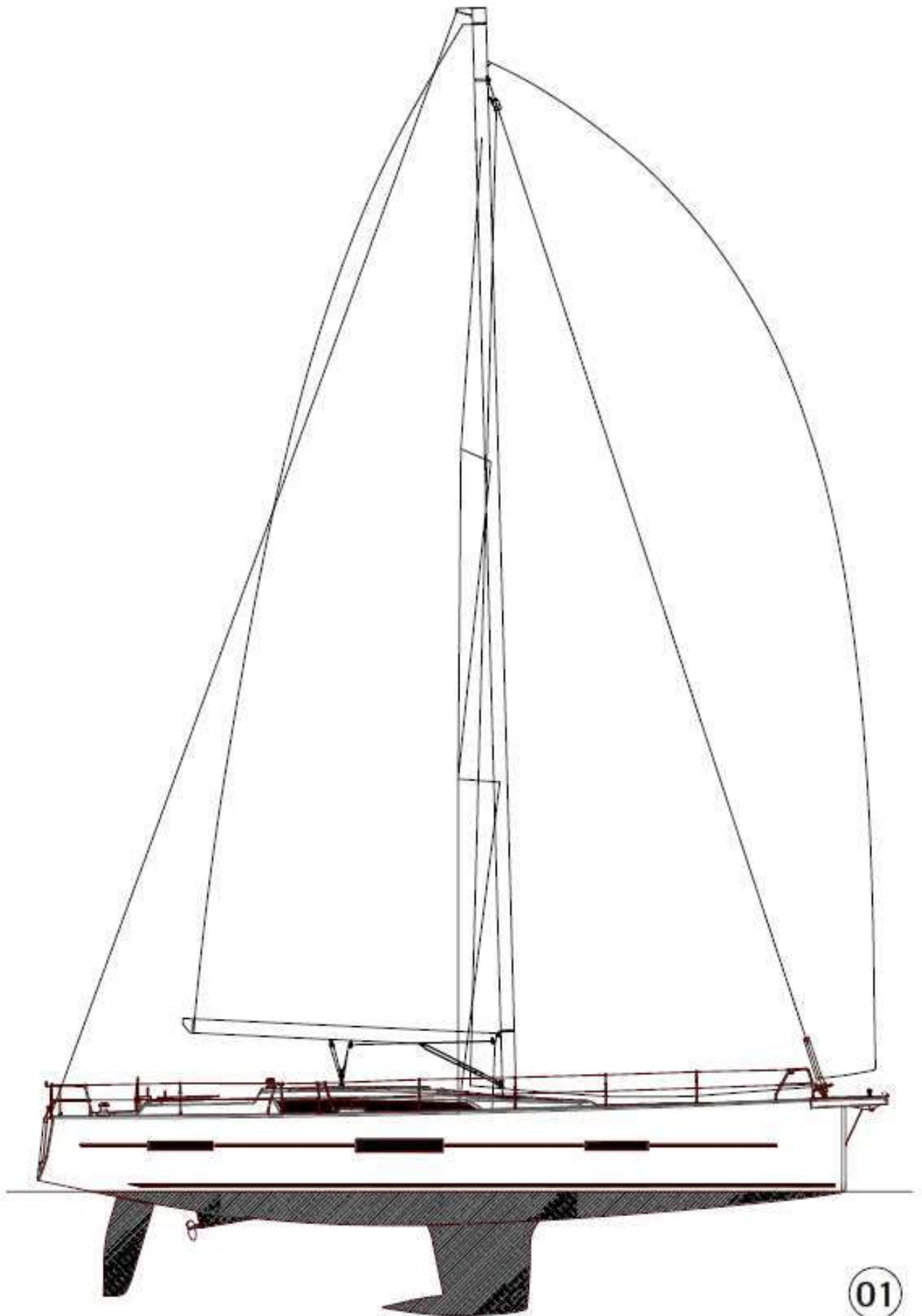

01

2. Accommodation layout

<i>Label</i>	<i>Description</i>
1	3-cabin version - central berth
2	3-cabin version - offset berth
3	Skipper cabin - option
4	4-cabin version
5	Pullman cabin - option

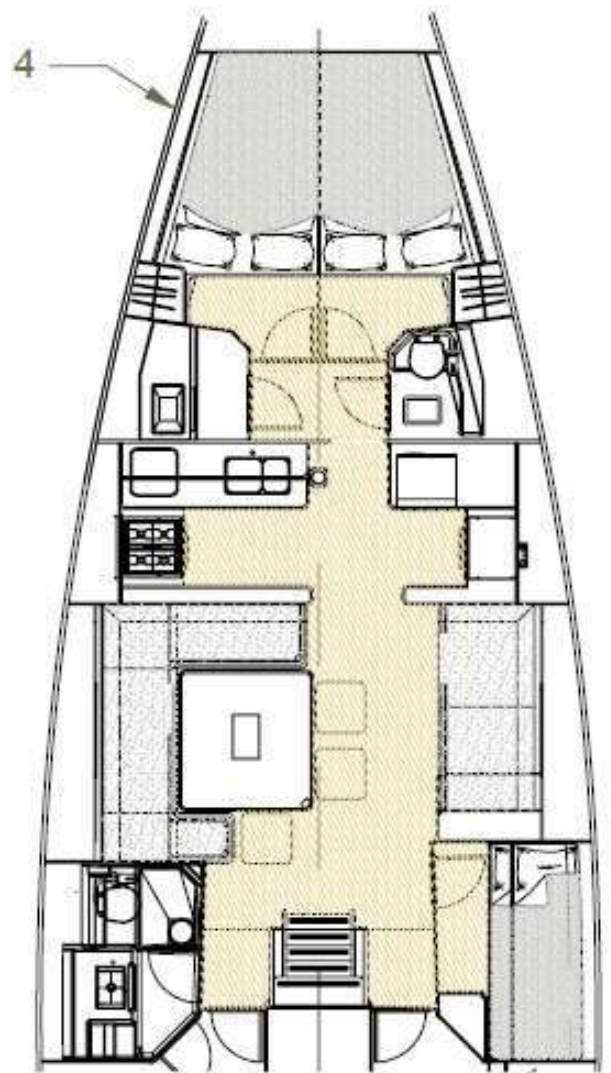
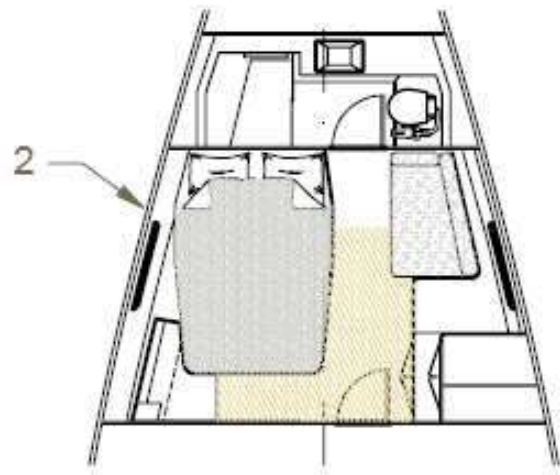

02

3. Deck fittings plan

<i>Label</i>	<i>Description</i>
1	Bow roller
2	Windlass
3	Mooring cleats
4	Stanchions
5	Stanchion bases
6	Central aft pushpit
7	Gate stanchions
8	Genoa track and traveler
9	5-sheave deck organizer
10	Mainsail track and traveler
11	Coachroof clutches
12	Halyard winches
13	Spinnaker winches*
14	Sheet winches
15	Genoa and mainsail clutches
16	Pulpit
17	Port and starboard aft pushpits
18	Shroud chainplates
19	U-bend
20	Spinnaker folding pad eyes
21	Genoa furling line clutch
22	Spinnaker tack line clutch*
23	Coachroof handrail
24	Horseshoe buoy bracket
25	Folding bathing ladder
26	Safety ladder
27	Self-tacking jib track
A	Jackline anchor points: Port & starboard cleats
B	Port & starboard towing points
C	Hatches must be closed when underway
D	“Man overboard”: swim ladder
E	Life raft stowage
F	Anchor point for safety harness
G	Lockers must be closed when underway
H	Tender stowage location
*	Option

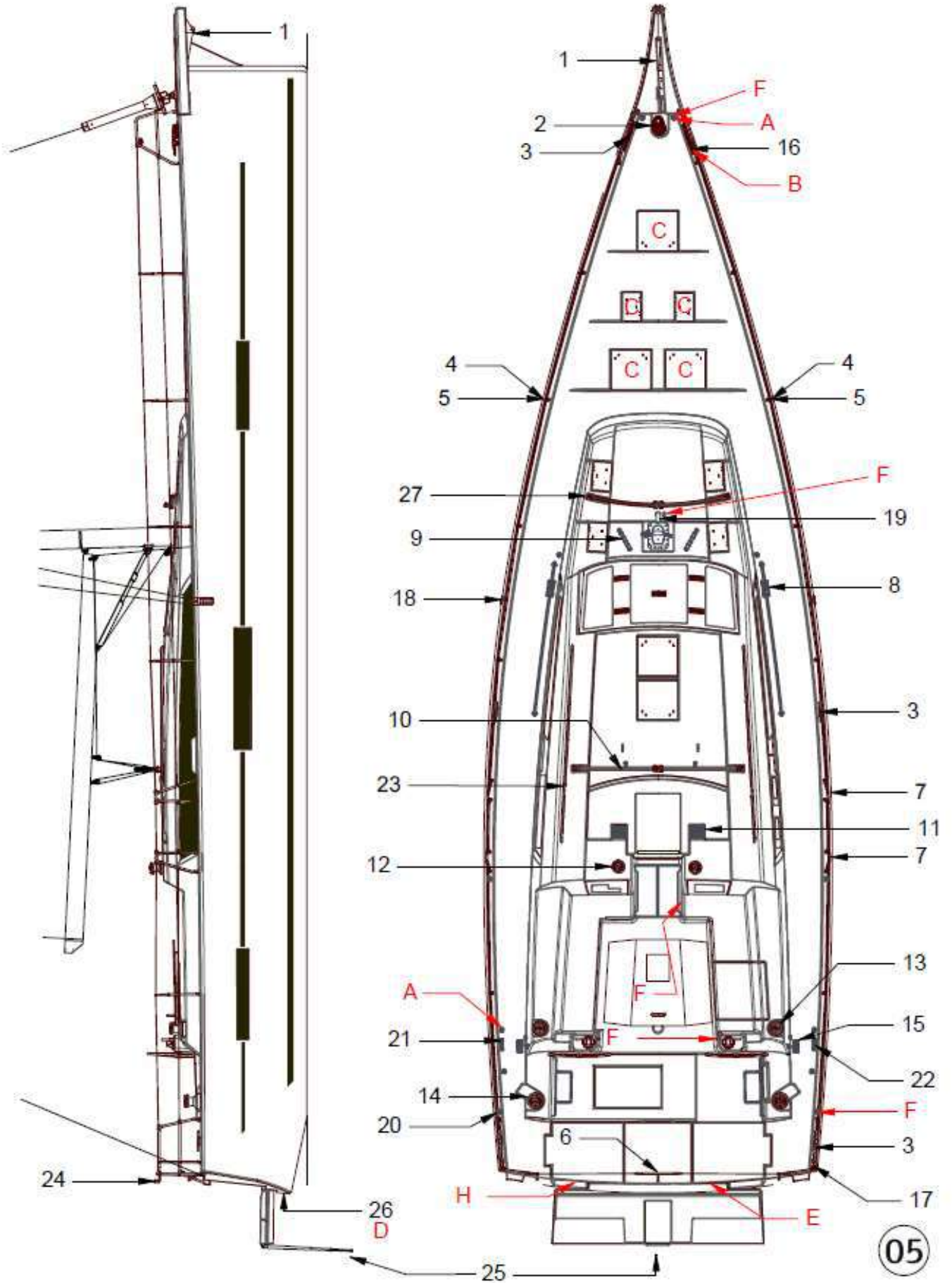

4. Sail plan

	Standard mast
I	20.43 m
J	6.20 m
P	20.00 m
E	6.20 m
Self-tacking jib LP (87%)	5.53 m
Genoa LP (107%)	6.81 m
Mainsail area	72 m ²
Self-tacking jib area	51 m ²
Genoa area *	69 m ²
Code 0 * area	152 m ²
* Option	

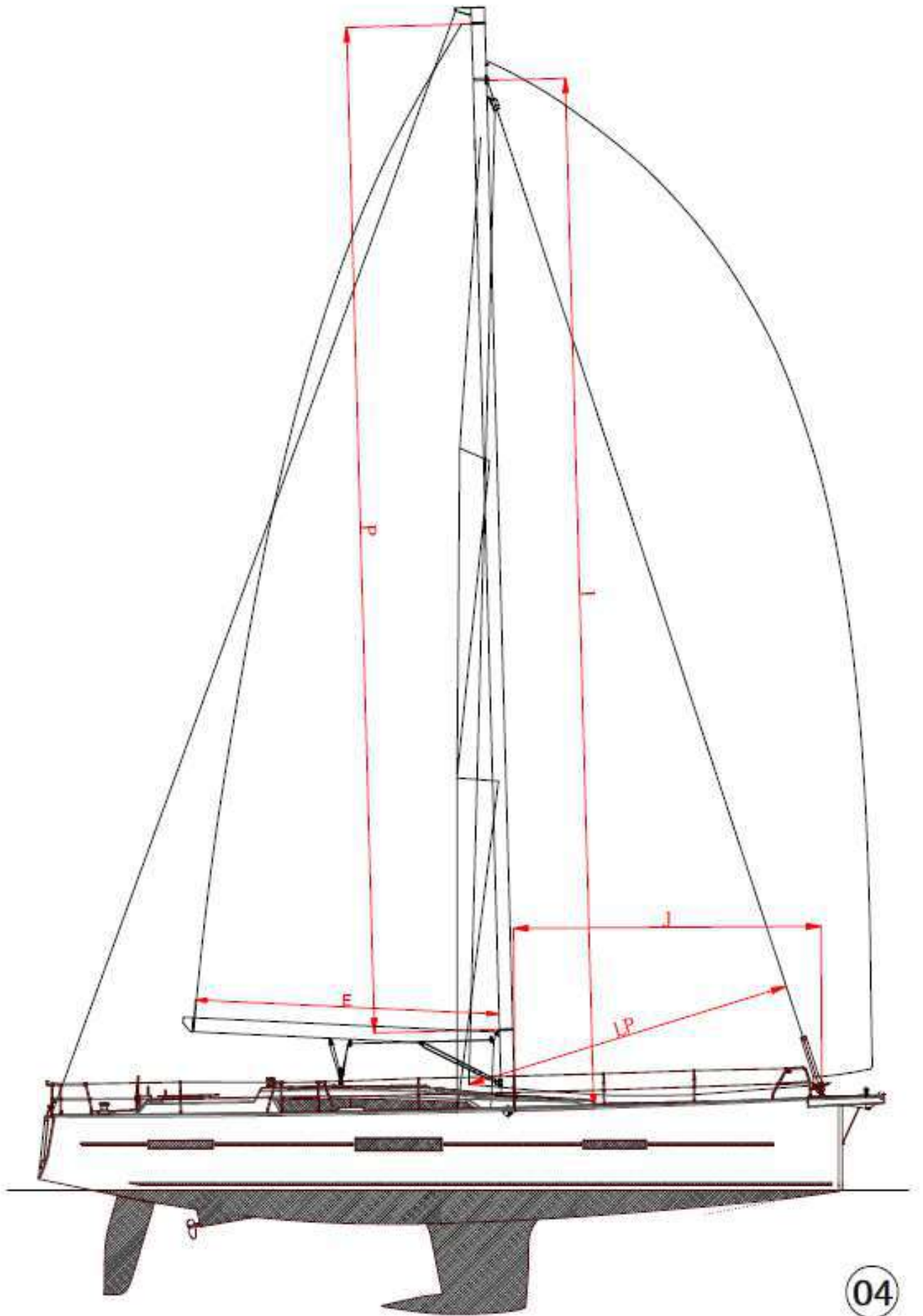

04

5. Halyard and sheet operating diagram

<i>Label</i>	<i>Description standard mast</i>
1	Mainsail traveler trim
2	Mainsail foot
3	Reef 1
4	Reef 3
5	Mainsail halyard
6	Spinnaker halyard*
7	Releasable forestay*
8	Self-tacking jib sheet
9	Genoa halyard
10	Reef 2
11	Boom vang
12	Standard mainsheet
13	Genoa sheet*
14	Genoa traveler adjustment*
15	Genoa furling line
16	Spinnaker tack*
17	Spinnaker sheet*
*	Option

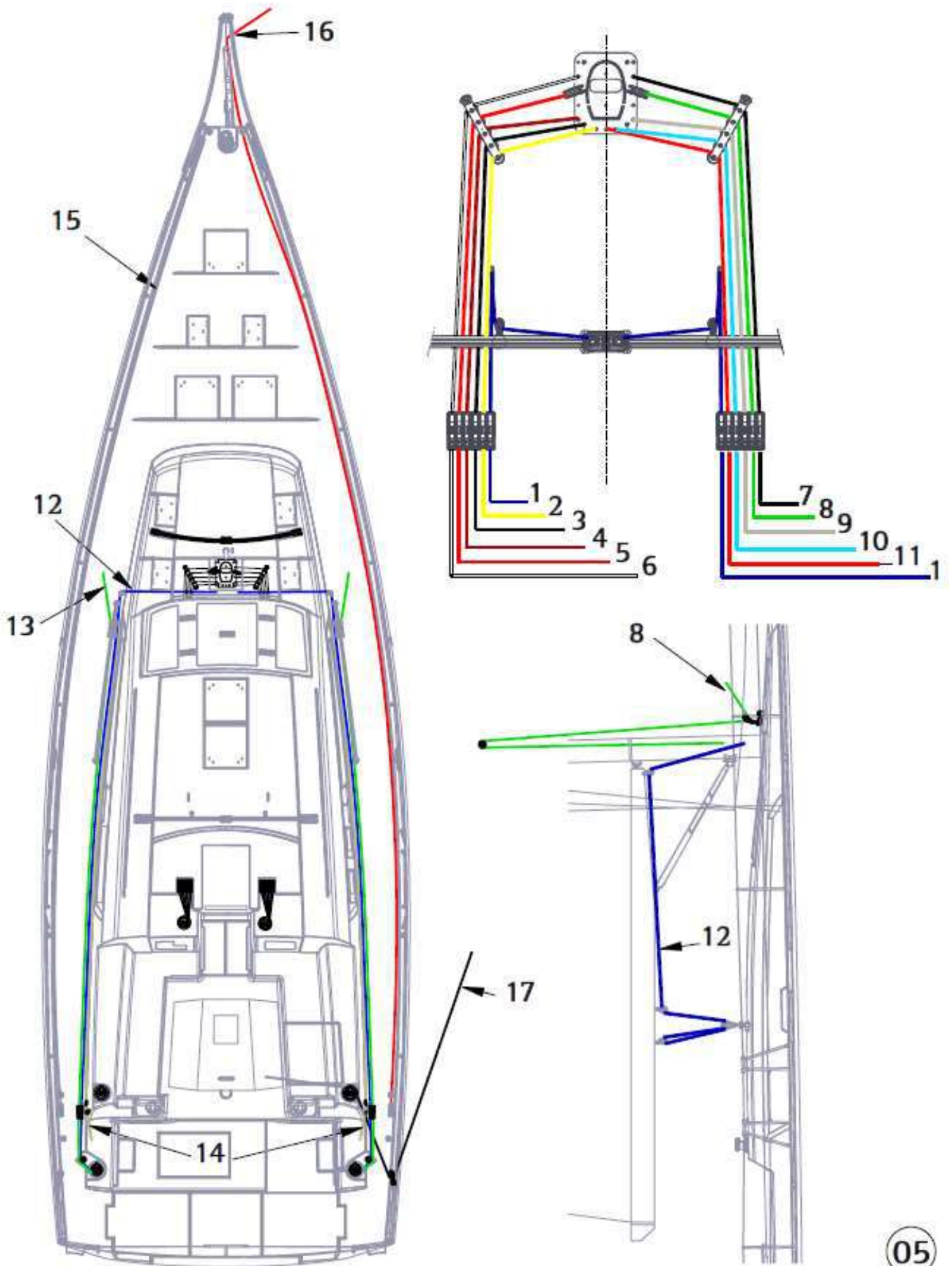

05

6. 220V electric panel

<i>Label</i>	<i>Description</i>	
1	Battery charger	16A
2	Water heater	16A
3	Electrical outlet	16A
4	Electrical outlet	16A
5	Residual current device	40A

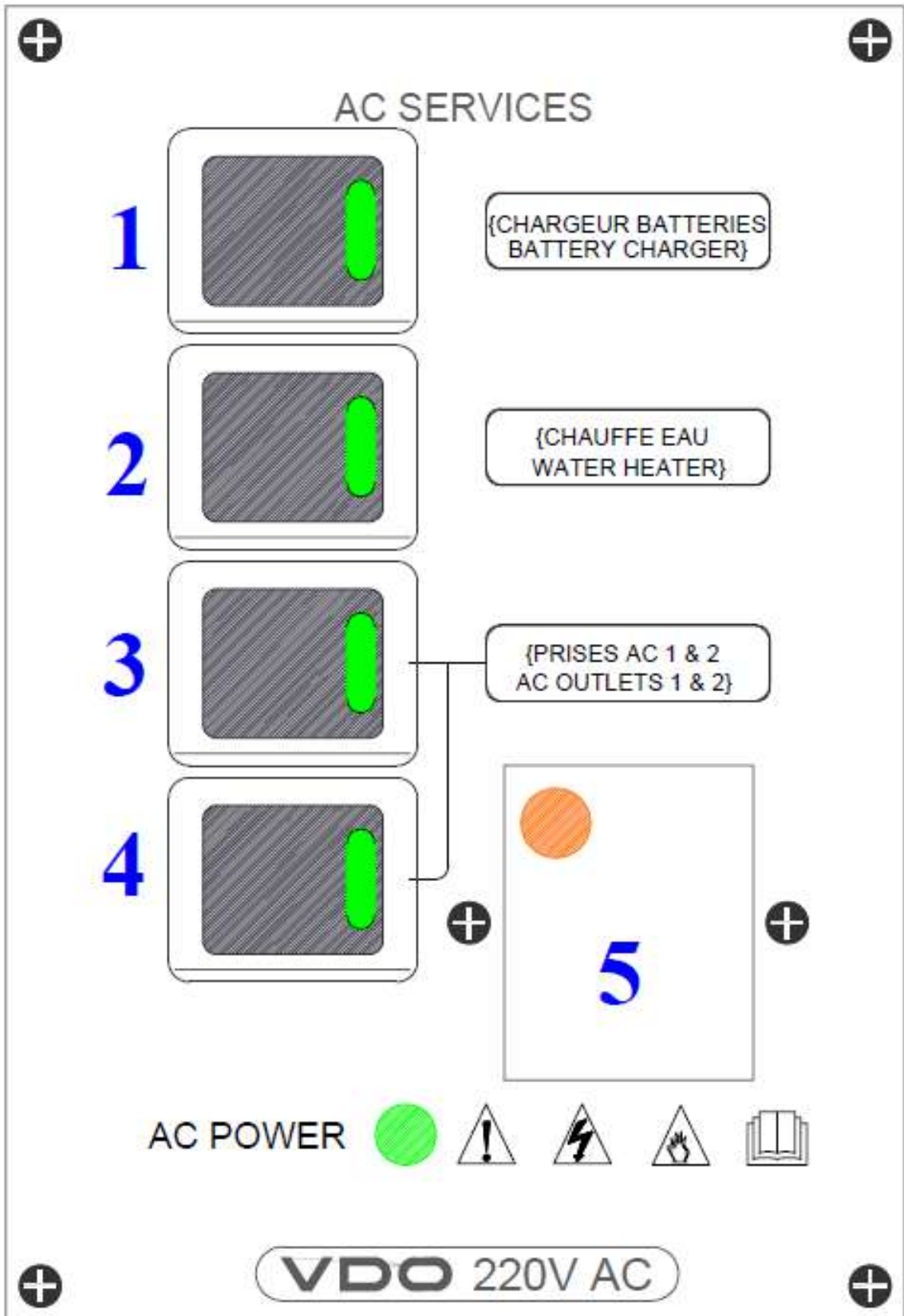

7. 220V circuit diagram

<i>Label</i>	<i>Description</i>
<i>Facilities</i>	
A	220V Shore cable **
B	Shore AC connection
C	32A Electrical box with main circuit breaker
D	Charger
E	CE waterproof plug connection
F	Water heater
G	220V 10A outlets
H	220V microwave oven*
I	Connector (back panel of electrical cabinet)
J	G Connector
K	220V/115V electric panel
<i>Electrical wiring colors</i>	
<i>b</i>	light blue
<i>g</i>	green
<i>m</i>	brown
<i>n</i>	black
<i>r</i>	red
<i>v</i>	green/yellow
<i>w</i>	white
*	Option
**	Not supplied

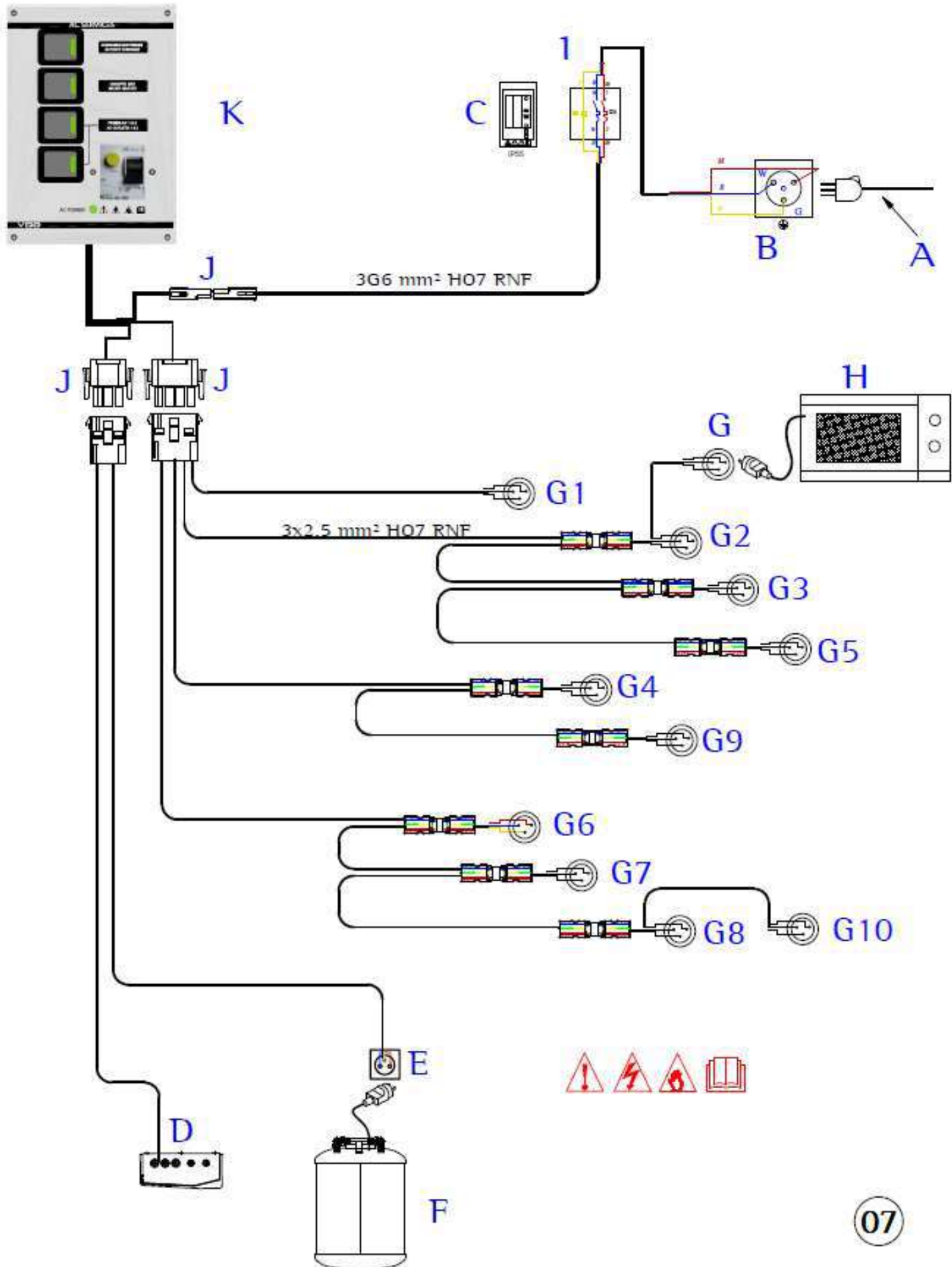

8. 220V circuit diagram

<i>Label</i>	<i>Description</i>
<i>Facilities</i>	
A	220V Shore cable **
B	Shore AC connection
C	32A Electrical box with main circuit breaker
D	Thruster charger (bow and stern) *
E	Watertight outlet for washing machine or dishwasher*
F	Dishwasher *
G	Washing Machine *
H	Air conditioning *
I	Watermaker 12V/220V - 100L/mn*
J	Panel connector
K	220V/115V electric panel
L	Quattro inverter outputs (x3)*
M	Junction box (outlets)* Electrical box with differential circuit-breaker 16A-30mA
N	Electrical box with differential circuit-breaker 32A-30mA
O	
P	Inverter**
Q	Generator *
R	Generator control panel**
S	Combi Quattro generator control panel**
T	Combi Quattro 12V/220V/3000W*
U	Auxiliary battery bank
V	500 A fuse
W	Air conditioning circuit breaker box
X	WM, DW, PE, Watermaker circuit breaker box
Y	Generator earthing plate
Z	Engine battery
<i>Electrical wiring colors</i>	
<i>b</i>	light blue
<i>g</i>	green
<i>m</i>	brown
<i>n</i>	black
<i>r</i>	red
<i>v</i>	green/yellow
<i>w</i>	white
*	Option
**	Not supplied

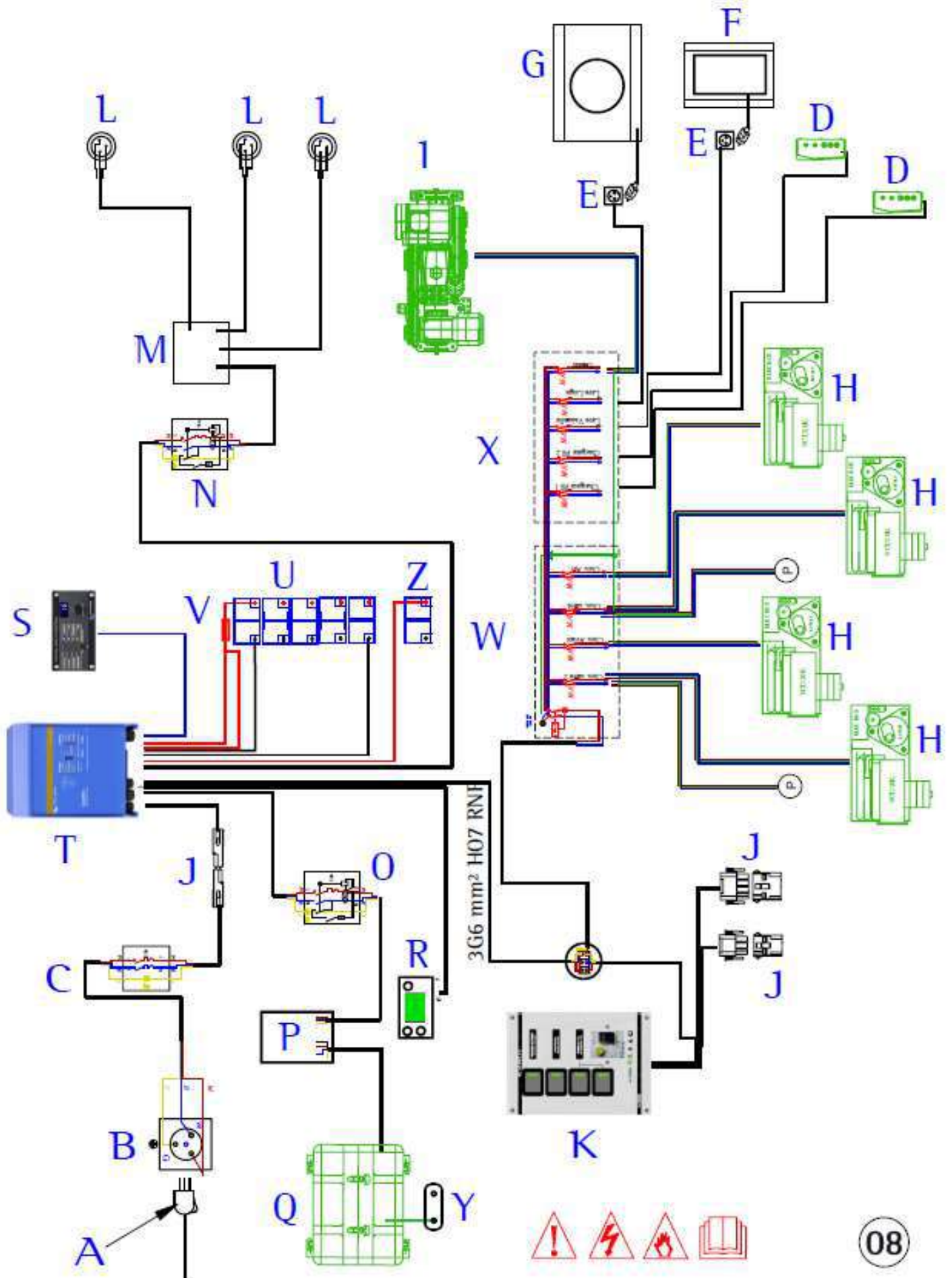

08

9. 220V electrical installation diagram

<i>Label</i>	<i>Description</i>
1	220V (or 110 V) outlet*
2	Water heater
3	Battery charger
4	Main circuit-breaker box
5	G Connector
6	Shore AC connection
	Microwave outlet*
7	Inverter outlets * (x3)
8	12V/220V/2KW Inverter*
9	220V/115V electric panel
10	12000BTU Turbo A/C*
11	8000BTU Turbo A/C*
12	DUO100 watermaker*
13	Watermaker panel*
14	Watermaker filter*
15	Watermaker membrane*
16	Generator*
17	Generator electrical panel*
18	A/C electrical panel*
19	WM, DW, watermaker and
20	thruster chargers electrical panel*.
*	Option

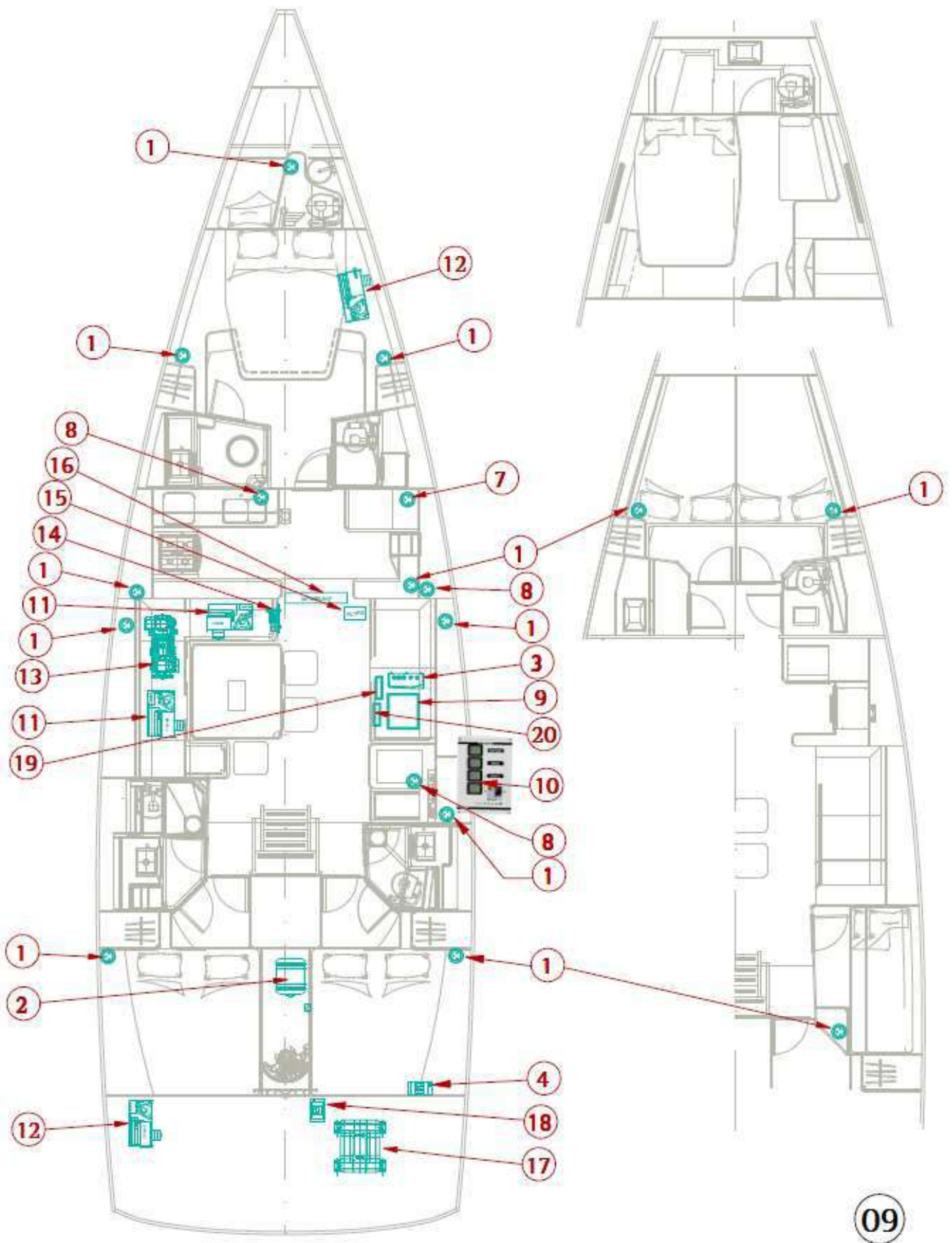

10. Fuse location diagram

<i>Label</i>	<i>Description</i>
A	Zone A - 12V Strip fuse 400A: optional bow thruster*
	Zone B - 12V Strip fuse 250A: panel protection
B	Strip fuse 125A: inverter protection*
	Strip fuse 500A: Quattro protection* Ampere meter shunt 100A
C	Blade fuse 15A: optional automatic bilge pump Zone C - 220V Differential circuit-breaker 16A: inverter protection*
	Single-pole + neutral 10A circuit breaker: bow thruster charger protection*.
	Single-pole + neutral 10A circuit breaker: stern thruster charger protection*.
	Single-pole + neutral 16A circuit breaker: dishwasher protection*
	Single-pole + neutral 16A circuit breaker: washing machine protection*
	Single-pole + neutral 16A circuit breaker: watermaker protection*
	Zone C - 12V Differential circuit-breaker 150A: windlass
D	Resettable circuit breaker type C 63A: watermaker.* Zone D - 12V Blade fuse 15A: Refrigeration unit*
	Blade fuse 1A: with gas solenoid valve*
	Blade fuse 10A: optional bow thruster*
	Blade fuse 15A: Cockpit table reading light*
	Blade fuse 40A: with auto-pilot option*
	Blade fuse 1A: heating option (x4)*
	Blade fuse 3A: with heating option)*
	Blade fuse 5A: with windlass option*
	Blade fuse 5A: with navigation instrument pack option*
	E
Single-pole + neutral circuit breaker: A/C compressor protection (x4)*	
F	
	Resettable circuit breaker type C 16A: electric toilet *
	Single-pole 6A circuit breaker: rear door piston cover*
	G
Strip fuse 80A: generator*	
H	Zone F - 220V 2-pole circuit breaker: shore protection
I	Zone I - 220V Differential circuit-breaker 32A: generator*

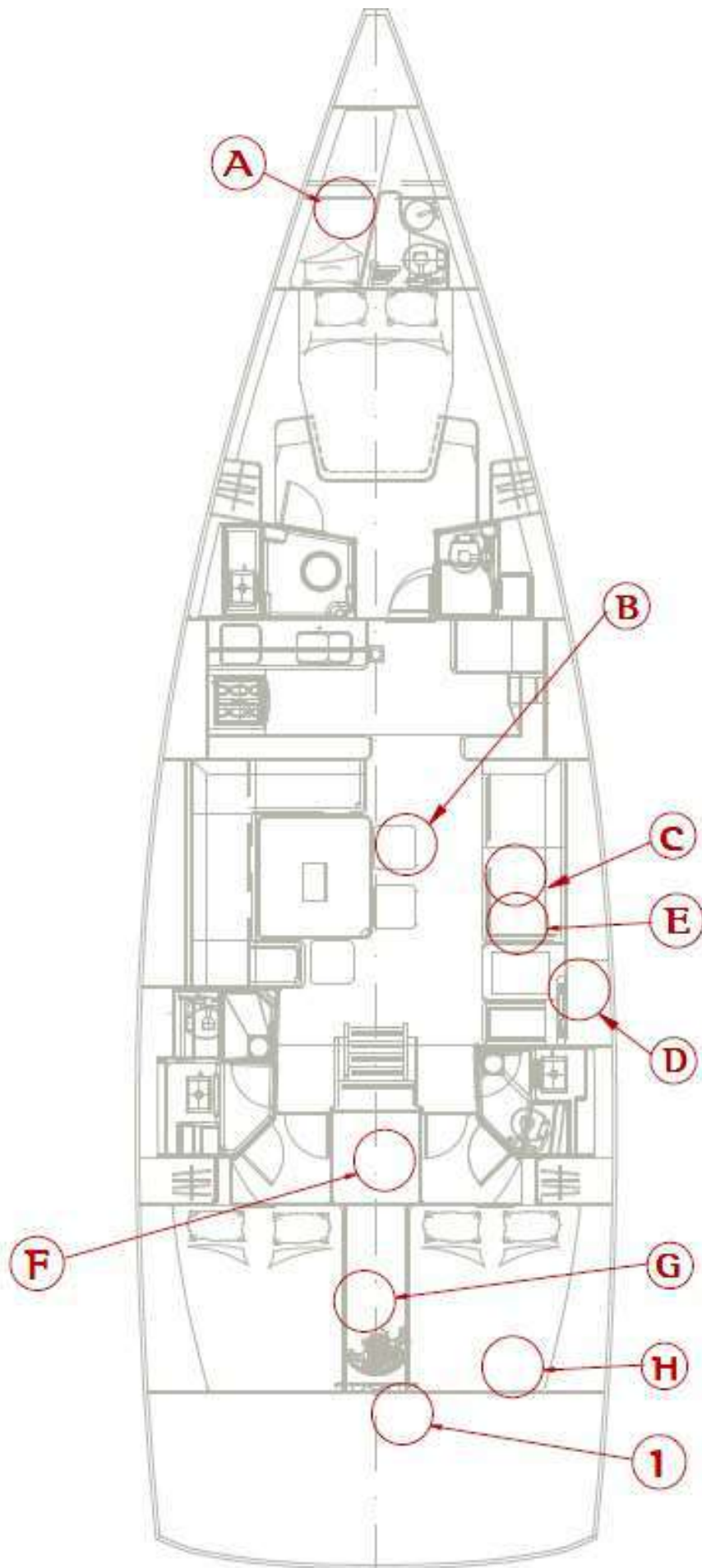

11. Charging and power system diagram

<i>Label</i>	<i>Description</i>
A	Windlass *
B	Windlass remote control*
C	Remote control relay*
D	8A fuse: engine test
E	Charger*
F	12V distribution panel
G	Single-pole 150A circuit breaker*
H	Auxiliary batteries (2 as std + 2 as option*)
I	200A fuse (auxiliary)
J	House batteries switch
K	5A fuse*
L	Alternator
M	Distributor
N	Starter
O	Engine battery
P	Engine battery isolator
Q	Windlass relay*
R	Bilge fan relay
S	5A fuse
T	Bilge fan
U	Inverter*
V	125A fuse: inverter*
W	Differential circuit-breaker: inverter*
X	Electrical outlet: inverter*
Y	12V relay: inverter*
Z	Ampere meter shunt
B-	-ve terminal (electrical panel)
B+	+ve terminal (electrical panel)
*	Option

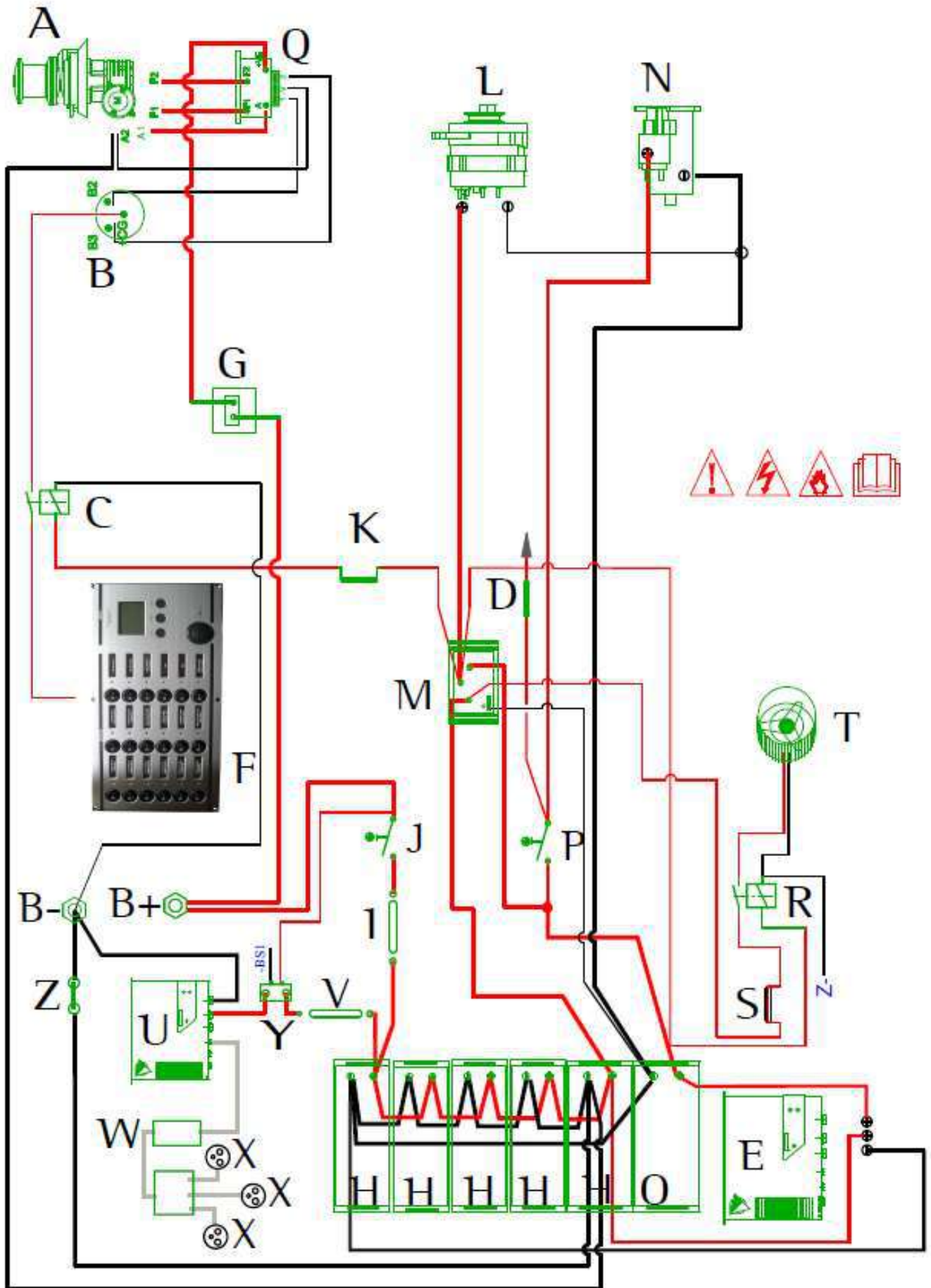

12. 12V electric panel

<i>Label</i>	<i>Description</i>	<i>Protection</i>
	<i>12V distribution panel</i>	
1	Miscellaneous 3	
2	Miscellaneous 4	
3	Miscellaneous 5	
4	Deck light	10A
5	Miscellaneous 2	10A
6	Windlass control	10A
7	Pressurized water system	10A
8	Bilge pump	15A
9	Shower pumps	10A
10	Navigation lights	10A
11	Mooring light	10A
12	Steaming light	10A
13	Fridge unit	10A
14	Navigation instrument pack	10A
15	Auto pilot	20A
16	Saloon lights	15A
17	Cabin lighting	15A
18	HIFI* / 12V outlet	10A
19	Voltmeter	
20	Freshwater gauge	
21	Fuel gauge	
22	12V outlet	10A

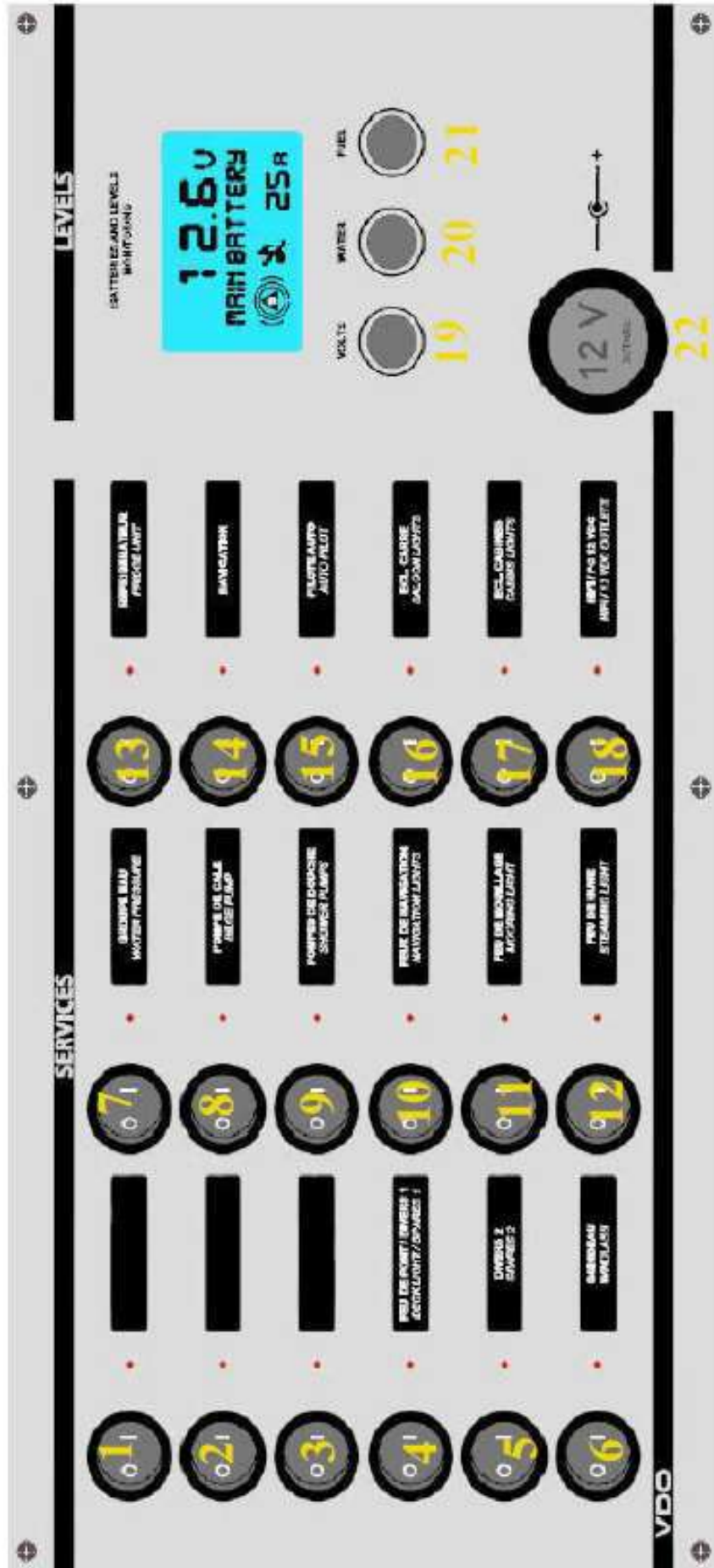

13. Terminal diagram

<i>Label</i>	<i>Description</i>
A	A Connector
1	Pressurized water system
2/5	Battery positive
3	Fridge unit
4	Bilge pump
6	Navigation equipment**
7	Shower drain pump
8	Battery negative
9	Autopilot engine
B	B connector
1	Navigation lights
2/5	Battery positive
3	Saloon/chart table lights
4	Mooring light
6	Cabin and toilet lights
7	Steaming light
8	Battery negative
9	HIFI* / 12V outlet
C	C Connector
6	Engine battery test - CCM
1/2/3/4	Aft watertank sensor - D2
9/10/11/12	Fore watertank sensor - D1
5	Fuel gauge sensor - G1
7/8	Negative
D	D Connector
1	Deck lights
2/5	Battery positive
3	Spares 5
4	Spares 2
6	Spares 4
7	Windlass control
8	Battery negative
9	Spares 3
	<i>Electrical wiring colors</i>
<i>n</i>	black
<i>r</i>	red
<i>w</i>	white
<i>o</i>	orange
<i>m</i>	brown
<i>b</i>	blue
*	Option
**	Not supplied

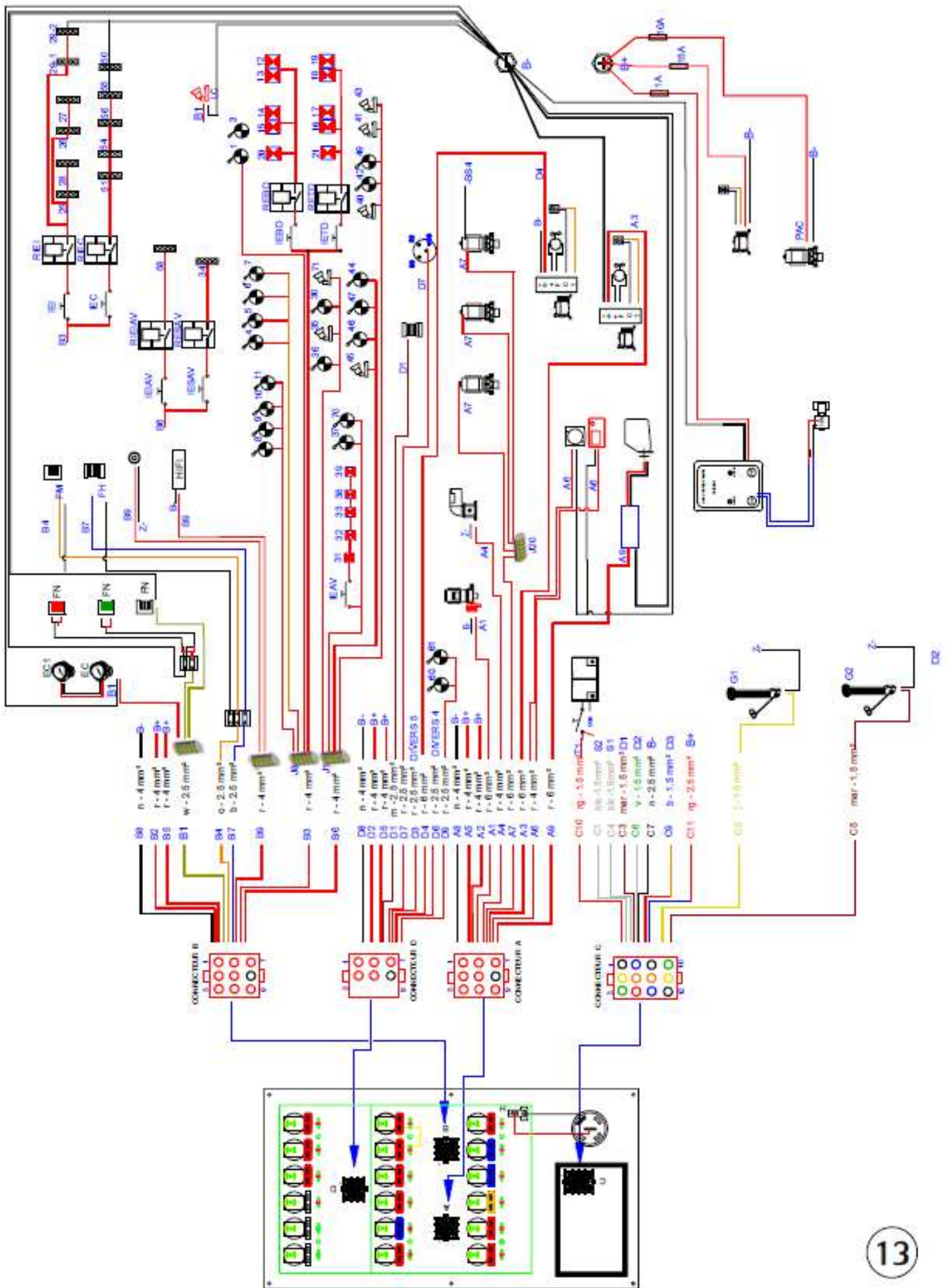

14. 12V electrical installation diagram

<i>Label.</i>	<i>Description</i>
1	Windlass*
2	Windlass relay*
3	Windlass remote control*
4	Fore freshwater gauge
5	Saloon freshwater gauge (x2)
6	Cockpit speaker
7	12V electric panel
8	Steering compass
9	Service fuse
10	Navigation lights (pulpit mounted)
11	Steaming light
12	Mooring light
13	Deck light
14	Cockpit table refrigeration unit*
15	Fuel gauge
16	Autopilot motor*
17	Refrigeration unit
18	Shower waste pump
19	Electric bilge pump
20	Engine battery 140 Ah
21	Auxiliary batteries 140 Ah (3+ 2*)
22	Water pump unit
23	Motor fan
24	Chart plotter
25	Engine and auxiliary battery isolator
26	12V watertight socket
27	Alternator
28	Starter
29	Depth/speed transducer*
30	Saloon speaker
31	Refrigeration unit freezer
32	Chain locker rinsing pump
33	Charge splitter
34	Freezer unit
*	Option

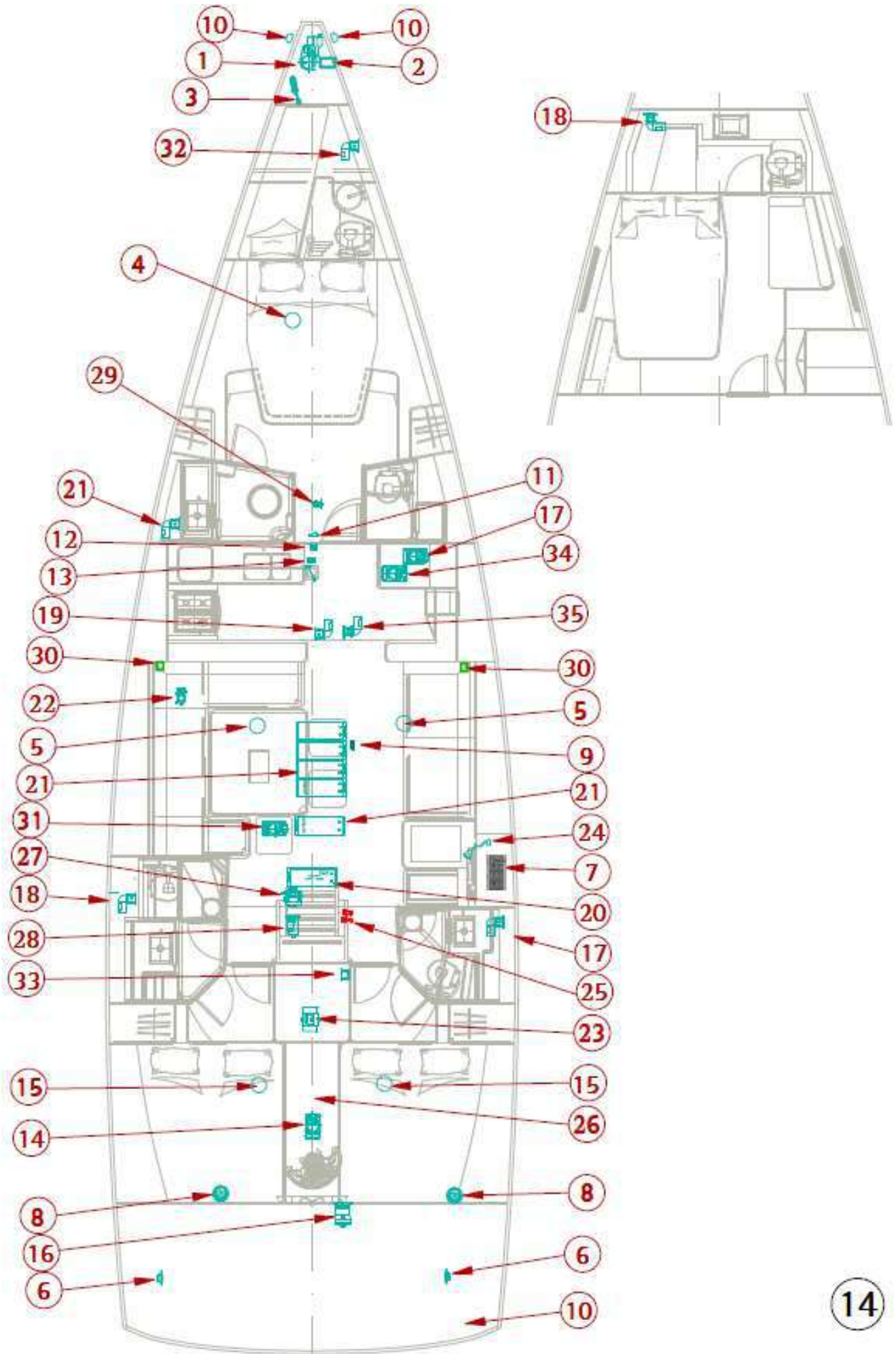

15. Lighting circuit

<i>Label.</i>	<i>Description</i>
1	Round ceiling light + switch
2	LED reading light
3	Black neoprene reading light
4	Mini chromed push-button switch
5	Saloon ceiling light
6	Flexible self-adhesive LED strip
7	Bathroom ceiling light
8	Impulse relay
9	Waterproof LED ceiling light
10	Flexible LED rail

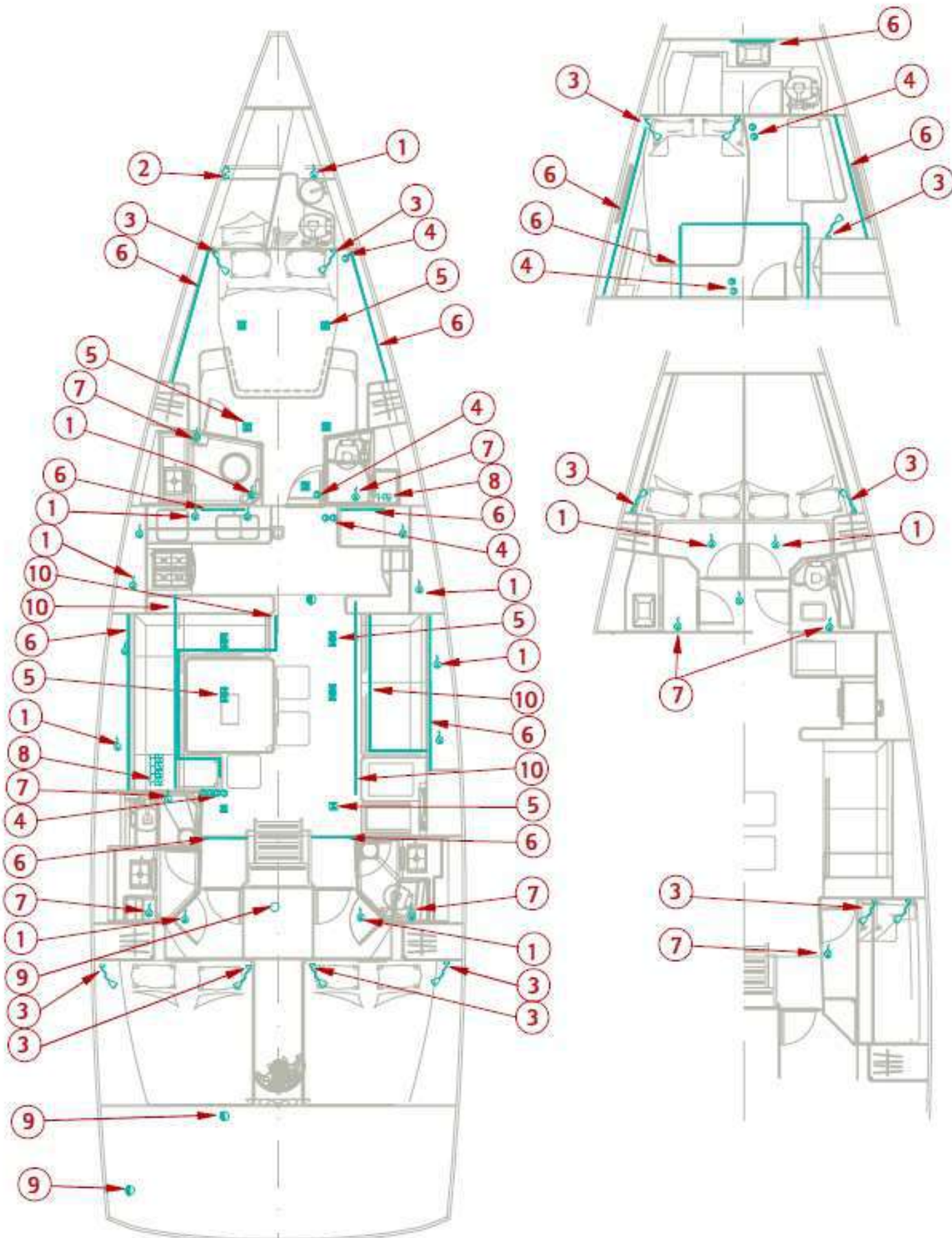

16. Steering system diagram

<i>Label</i>	<i>Description</i>
1	Rudder blade + stock
2	Rudder trunk
3	Lower bearing
4	Lower bearing and rudder rings
5	Top bearing
6	80 deg section
7	Section stop
8	Chain and rudder cable kit
9	Rudder cable sheaves
10	Spacer sheaves
11	Steering cable guide plates
12	Port bulkhead device
13	Starboard bulkhead device + brake
14	Steering wheel
15	Autopilot motor*
16	Pilot bracket shims*
17	Helm angle indicator*
18	Emergency tiller
*	Option

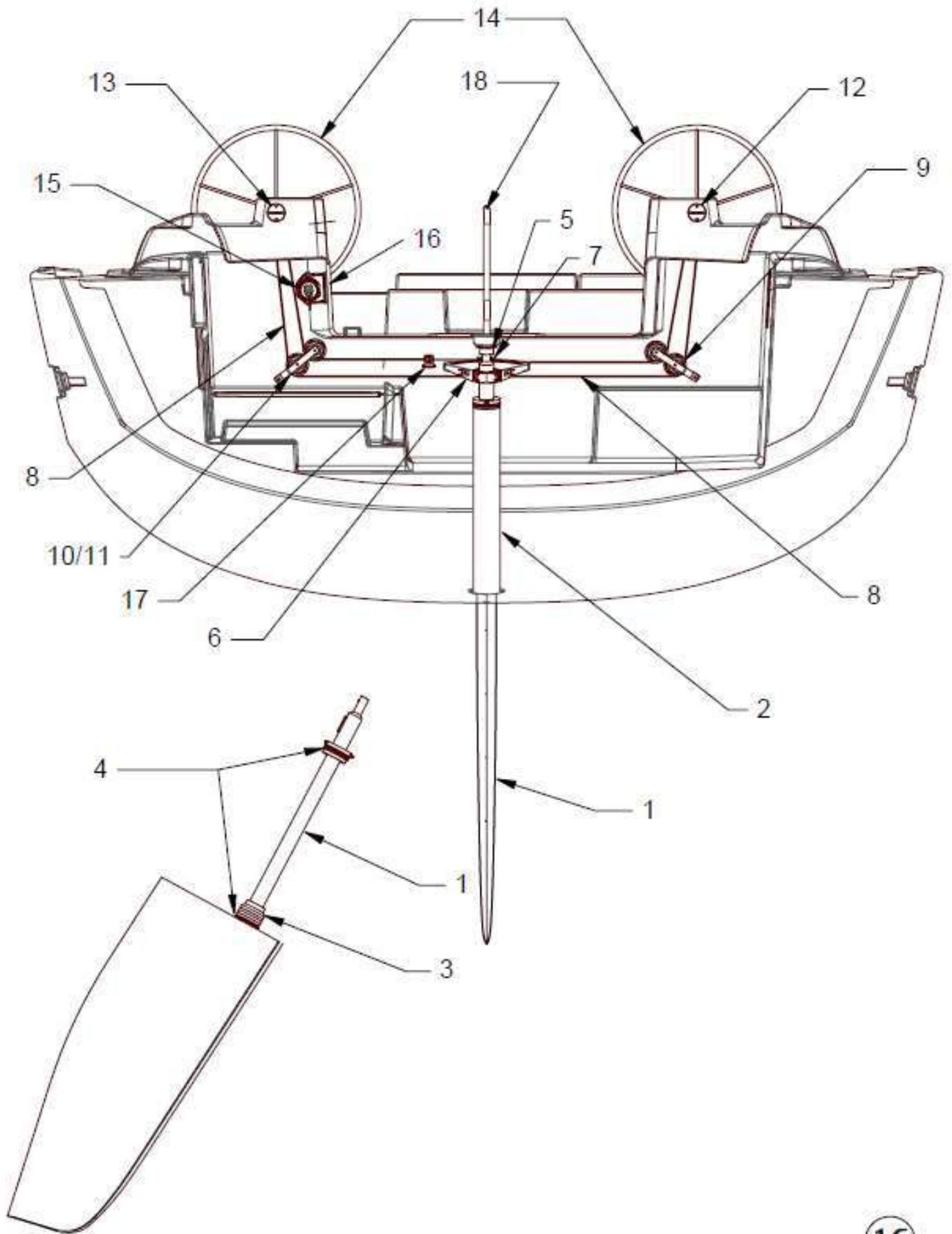



16

17. Gas system diagram

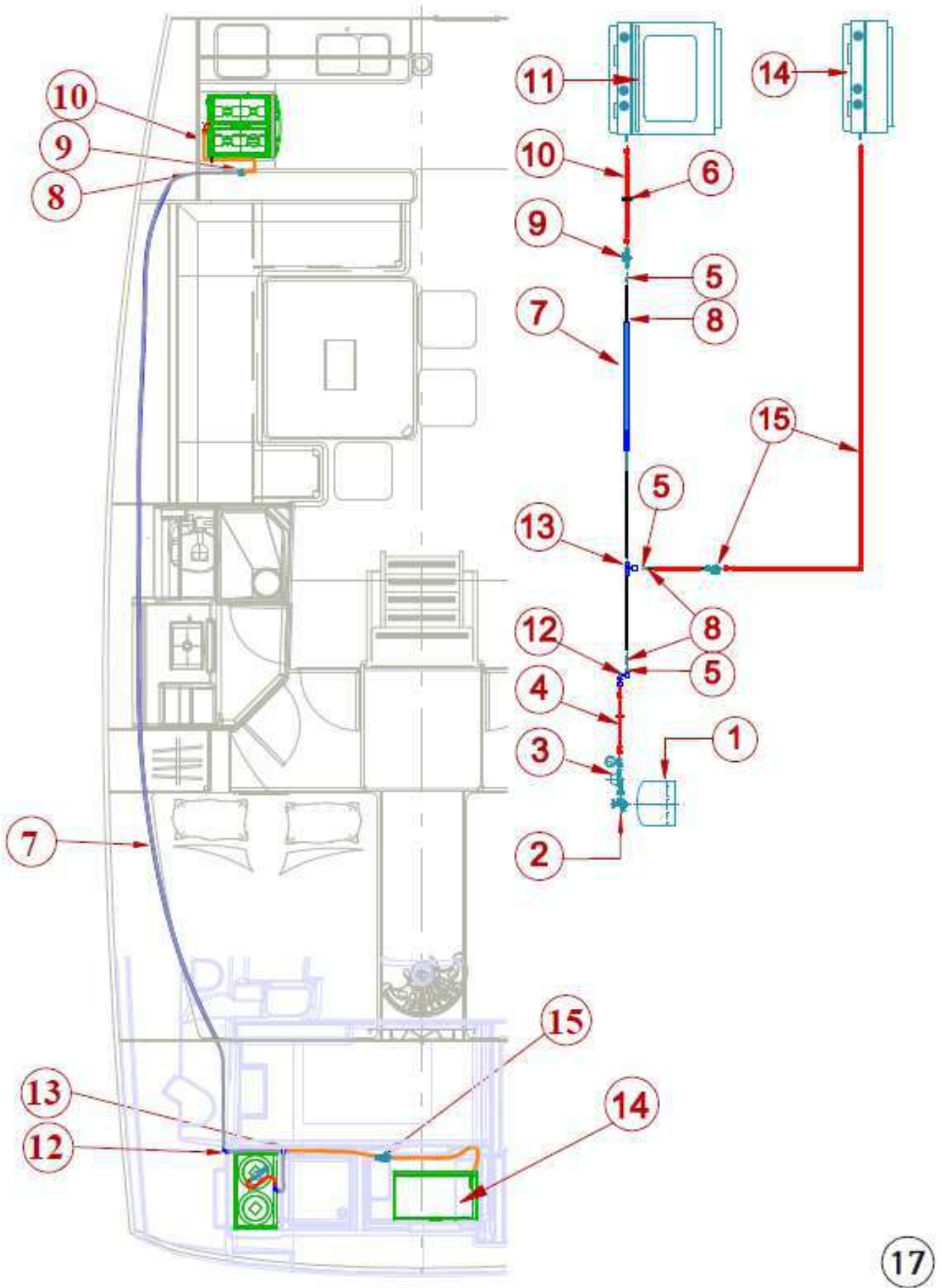
<i>Label</i>	<i>Description</i>
1	1.8 kg gas cylinder**
2	CE shut-off valve (Fr. or Ger.)
3	30 mbar CE regulator (Fr. or Ger.) / Pressure gauge
4	Medium-length connecting hose
5	Spacer/tube 6 x 8
6	Watertight bulkhead fitting
7	PVC pipe
8	6 x 8 copper pipe
9	CE gas shut-off valve
10	Long connection hose
11	Cooker/Oven
12	Bulkhead gas locker
13	T-fitting: plancha grill*
14	Plancha grill*
15	Plancha grill connection kit*
*	option
**	Not supplied



18. Abandon ship plan

<i>Label</i>	<i>Description</i>
 1 2 3 4 Wh	<p>Recommended fire-extinguisher stowage</p> <p>Cockpit locker: 1 kg powder fire-extinguisher 5A/34B**</p> <p>Saloon banquette: 1 kg powder fire-extinguisher 5A/34B**</p> <p>Galley: 1 kg powder fire-extinguisher 5A/34B**</p> <p>Skipper cabin (option)</p> <p>Engine compartment extinguishing hole</p>
	Emergency exit
	Fire blanket (recommended location)
**	Not supplied

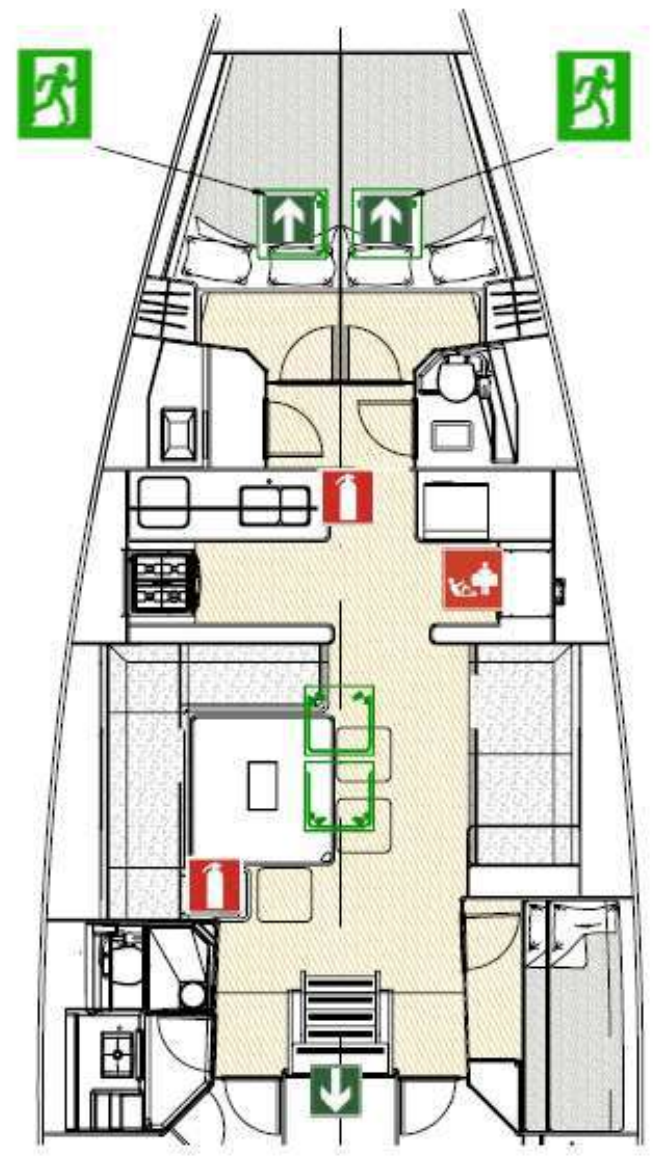
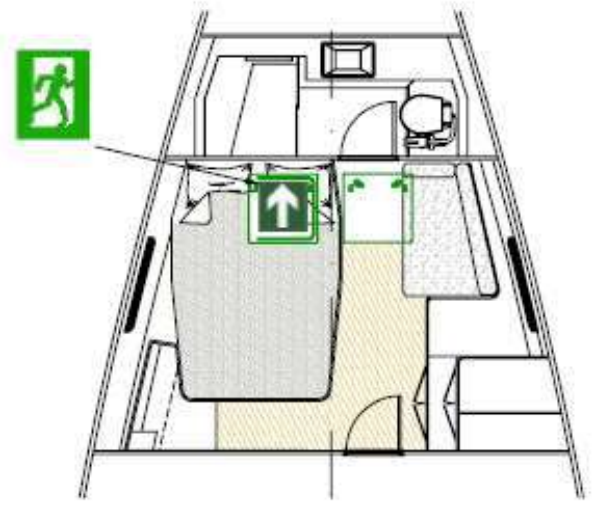
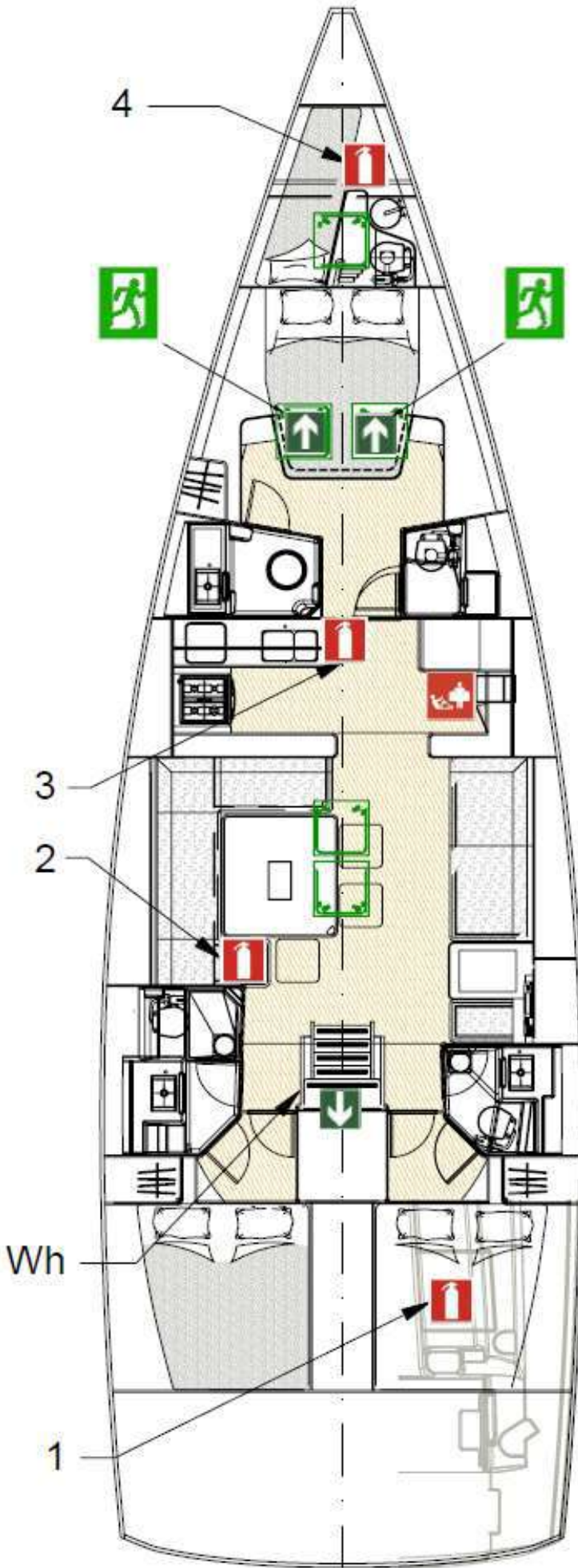

19. Freshwater system diagram

<i>Label</i>	<i>Description</i>
1	Filler deck plate
2	Filler hose
3	Vent
4	Vent hose
5	Fore water tank, 280 L
6	Stern water tank, 200 L (x2)
7	Hot water pipe
8	Cold water pipe
9	Pressurized water pump unit
10	Freshwater pump
11	Water heater
12	Bathroom mixer tap – shower head
13	Galley single-lever mixer tap
14	Deck shower
15	Bathroom mixer tap
16	1/2" 3-way manifold
17	MF reduction 3/4" - 1/2"
18	1/2" 1/4-turn FF seacock
19	3/4" WX F connector
20	1/2" WX M connector
21	Freshwater/seawater cock
22	Freshwater/seawater 3-way cock
23	Freshwater/seawater foot pump
24	Plancha grill mixer tap and shower head
25	Toilet seawater intake *
*	Option

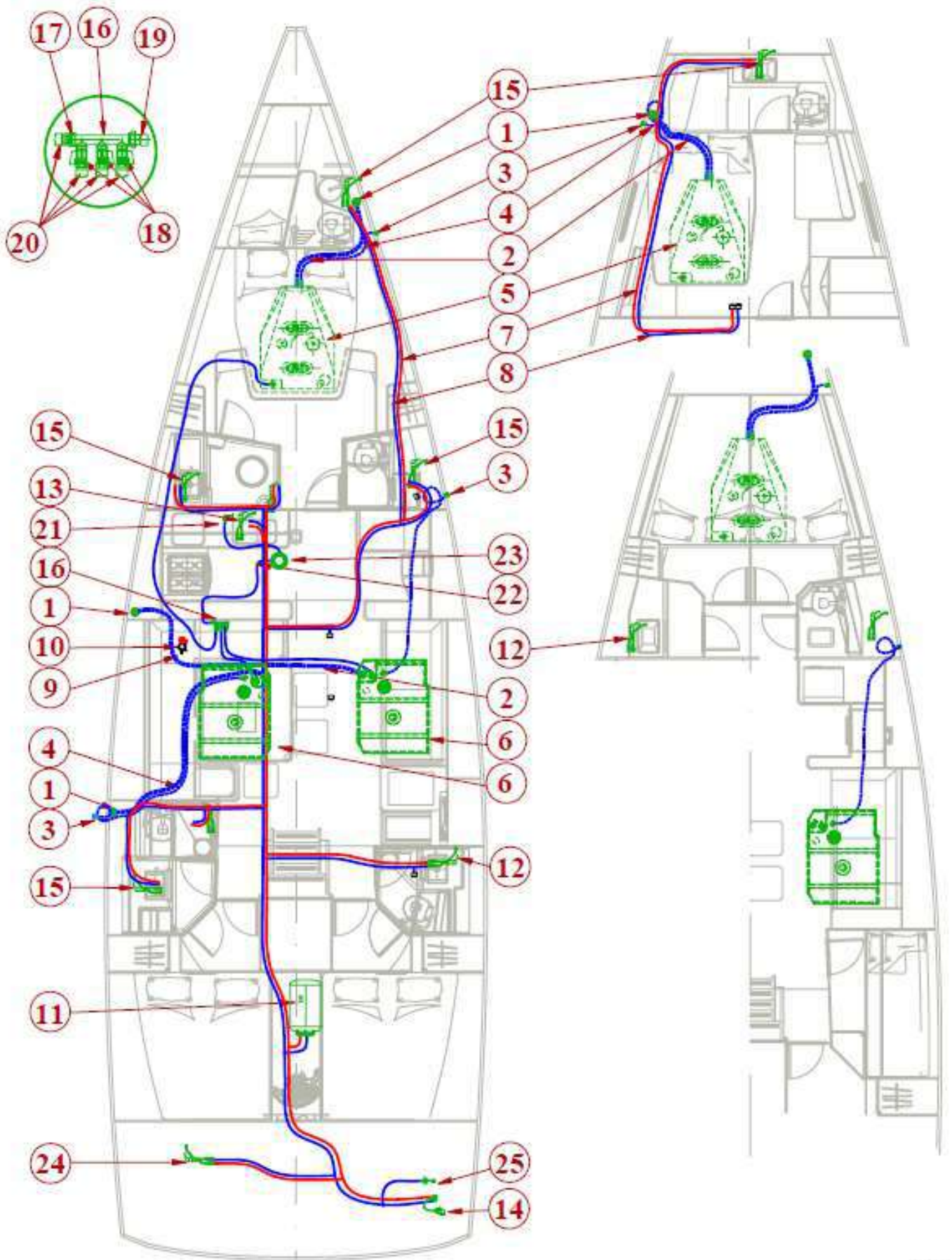

20. Drain system diagram

<i>Label</i>	<i>Description</i>
	<i>Electric bilge pump</i>
1	Ø25 discharge hose
2	Orca submersible bilge pump
3	Skin fitting 1"
	<i>Manual bilge pump</i>
4	Ø25 Strainer with non-return valve
5	Ø25 discharge hose
6	Manual bilge pump
7	Skin fitting 1"
	<i>Automatic bilge pump</i>
8	Automatic switch
9	Supersub submersible bilge pump
10	Ø25 discharge hose
11	Skin fitting 1"

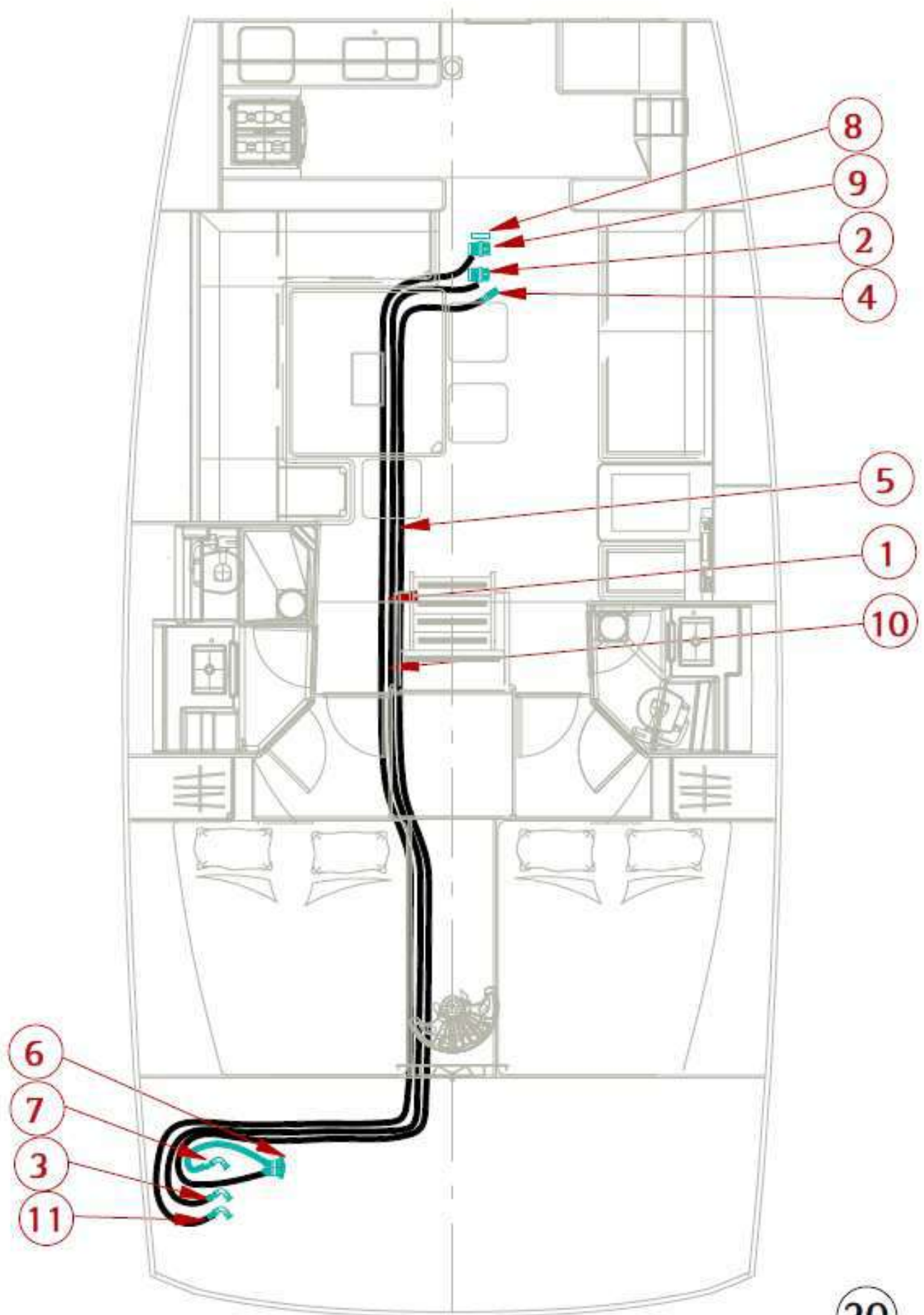

21. Skin fitting location diagram

<i>Label</i>	<i>Description</i>	<i>Ø</i>
<i>Skin-fittings + seacocks</i>		
1	Galley sink discharge	1-1/4"
2	Wash-basin/shower outlet	1"
3	Toilet seawater intake	3/4"
4	Toilet discharge	1-1/2"
5	Washbasin outlet	1"
6	Foot pump seawater intake	1/2"
7	Rope locker outlet	1-1/4"
8	Cockpit sink discharge	1"
16	Chain locker rinse*	1/2"
17	Water separator discharge*	1"
18	Air-conditioning condensate discharge*	1/2"
19	Air-conditioning discharge* (x3)	1/2"
20	Watermaker discharge*	1/2"
<i>Skin-fitting</i>		
9	Electric bilge pump discharge	1"
10	Manual bilge pump discharge	1"
21	Automatic electric bilge pump discharge	1"
<i>Strainer skin fitting*</i>		
11	Seawater intake for air-conditioning*	1"
12	Seawater intake for watermaker*	1/2"
13	Seawater intake for generator*	3/4"
*	Option	

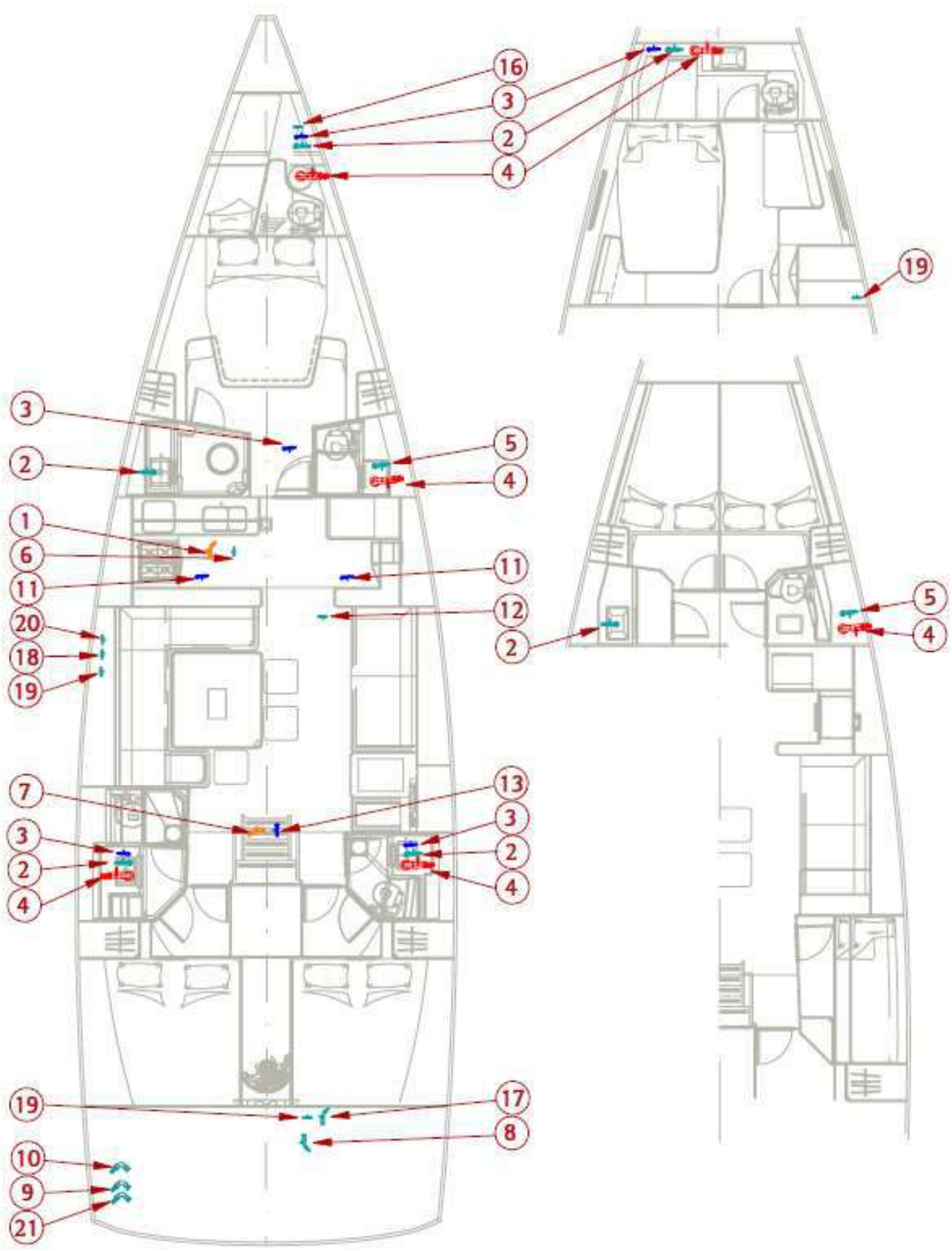

22. Mechanical installation diagram

<i>Label</i>	<i>Description</i>
1	Engine + reverse gear
2	Engine control unit
3	Engine controls
4	Polyester frame
5	Propeller
6	Stern tube
7	Stern gland
8	Propeller shaft
9	Coupling flange
10	Propeller shaft bearing
11	Ventilation grilles
12	
13	Foam insulation
14	Strainer skin fitting*
15	Exhaust outlet
16	Anti-siphon elbow
17	Seawater intake seacock
18	Raw water strainer
19	Waterlock silencer
20	Bilge fan
21	Engine battery
22	Charge splitter
23	Isolator

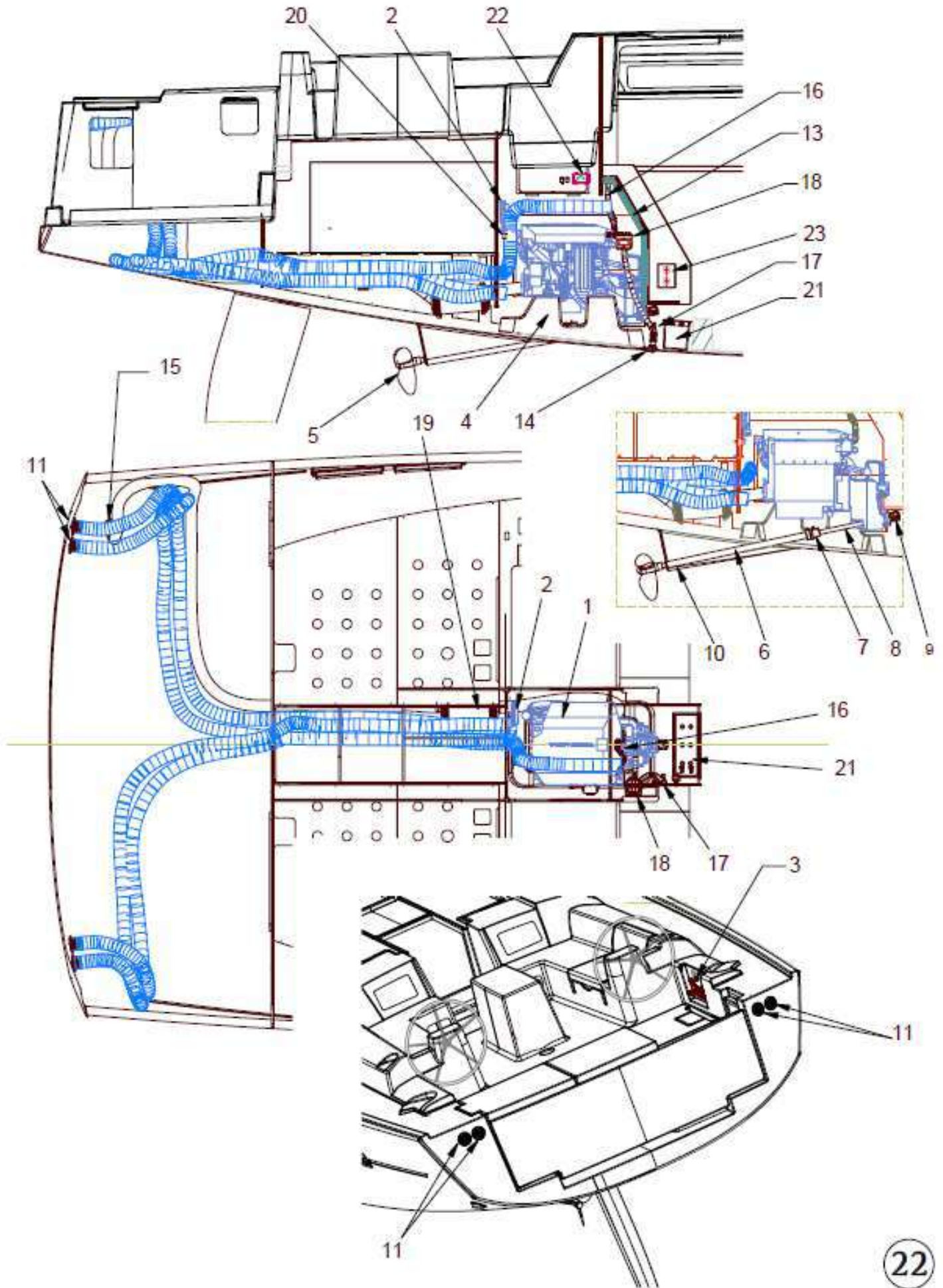

23. Gas system diagram

<i>Label</i>	<i>Description</i>
1	Port fuel tank
2	Fuel shut-off valve
3	Overflow vent
4	Fuel deck plate
5	Tank vent
6	Starboard fuel tank
7	Port/starboard valve coupling
8	Quick shut-off valve
9	Fuel pre-filter

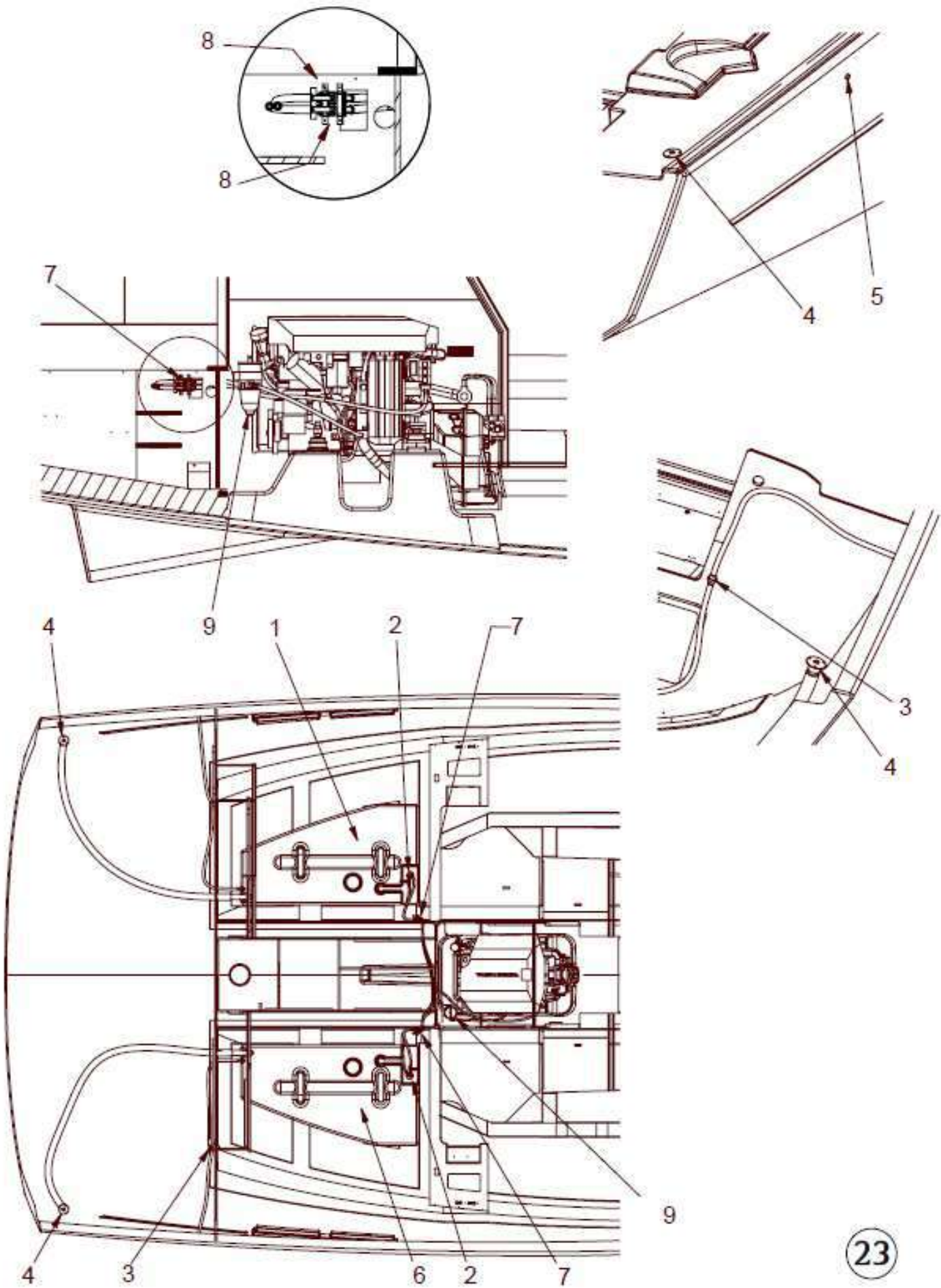

24. Holding tank installation diagram

<i>Label</i>	<i>Description</i>
1	Skin fitting & seacock, 3/4"
2	50 mm Ø Waste deck plate
3	Skin fitting & seacock, 1-1/2"
4	20 mm Ø hose
5	38 mm Ø anti-odor hose
6	51 mm Ø anti-odour hose
7	3/4" chromed brass vent
8	Holding tank, 50 L
9	Holding tank, 35 L*
X	U-bend * Option

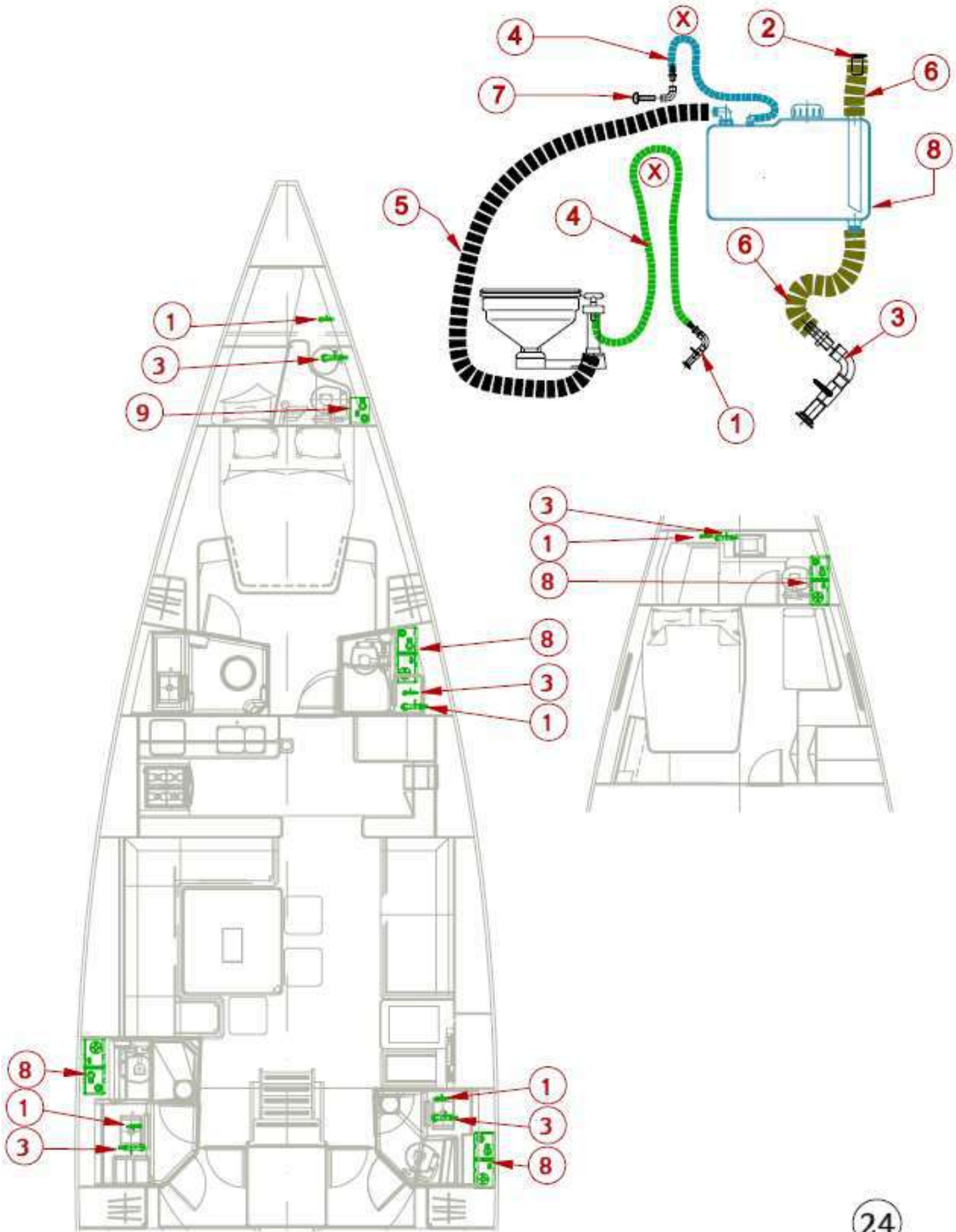

25. Lifting diagram

<i>Label.</i>	<i>Description</i>
	See red triangular marker under deck-line
	Light displacement: 17600 kg
	Midship beam: 5.04 m
	Standard draft: 2.50 m

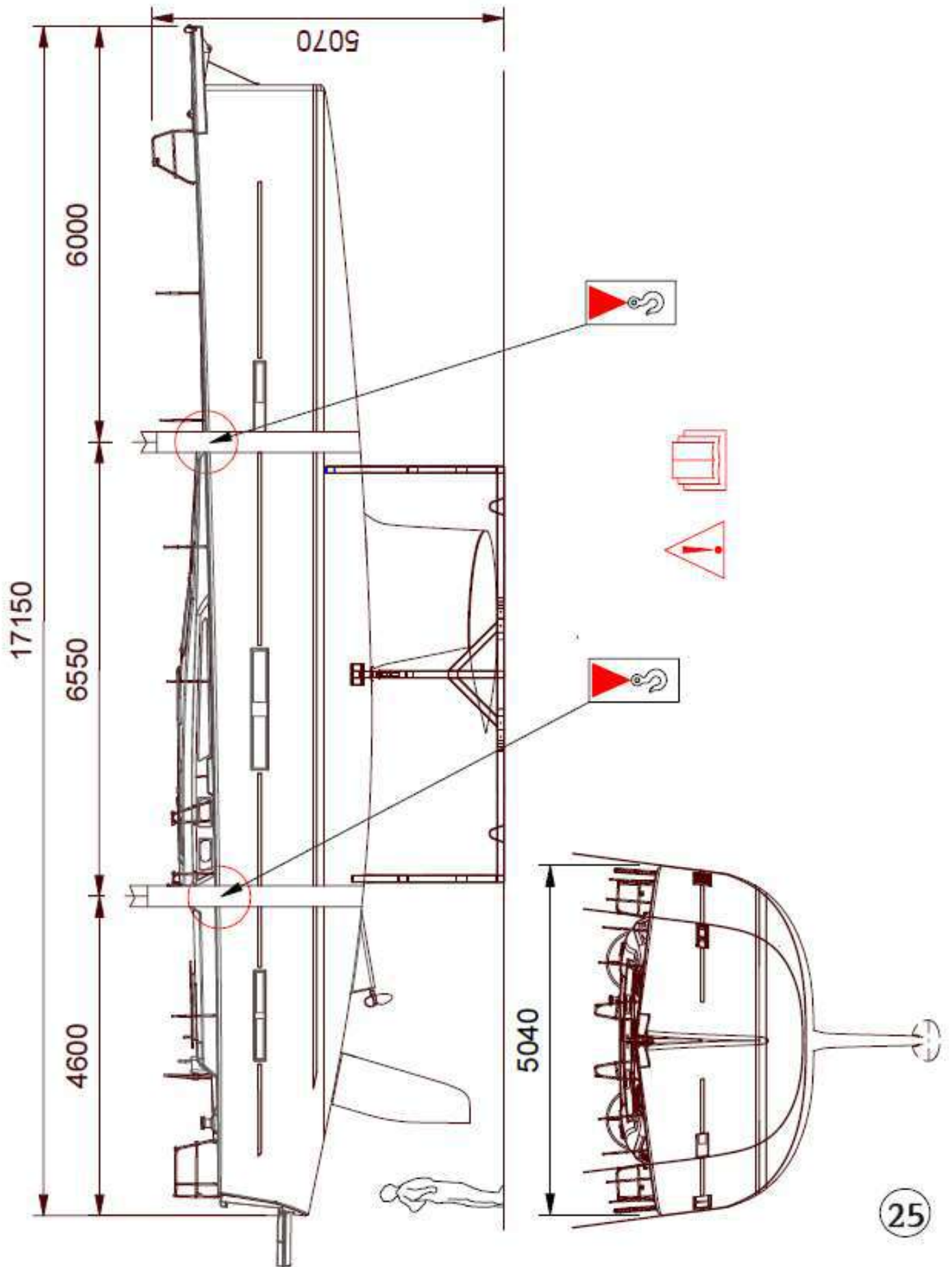

26. Navigation lights

<i>Label</i>	<i>Description</i>	
A	Under sail	
B	Under power	
C	Mooring	
D	12V electric panel	
1	Navigation lights - LED	2 Nm
2	Mooring light	2 Nm
3	Steaming light	3 Nm

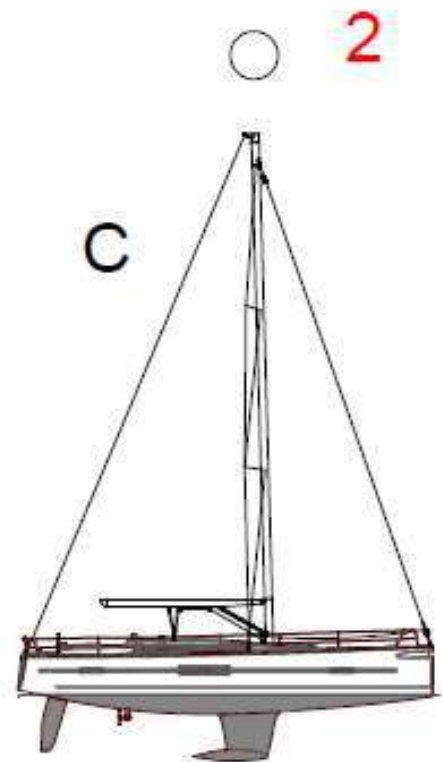
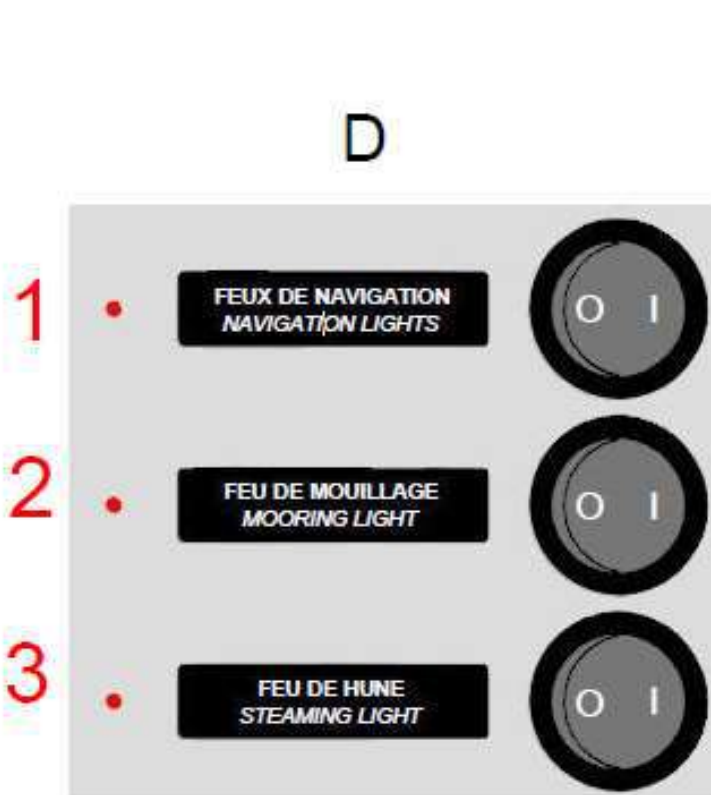
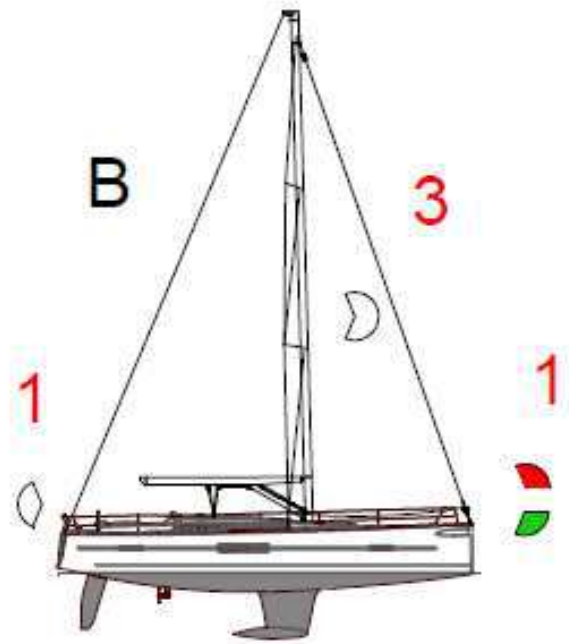
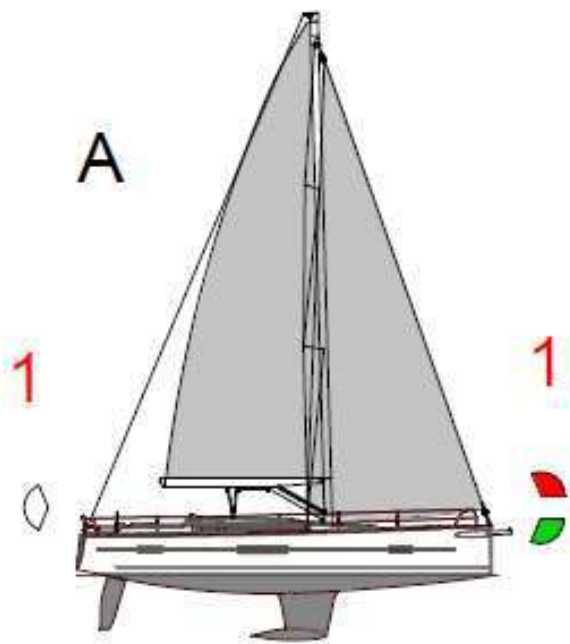



NOTES