

## QNN INTERFACE

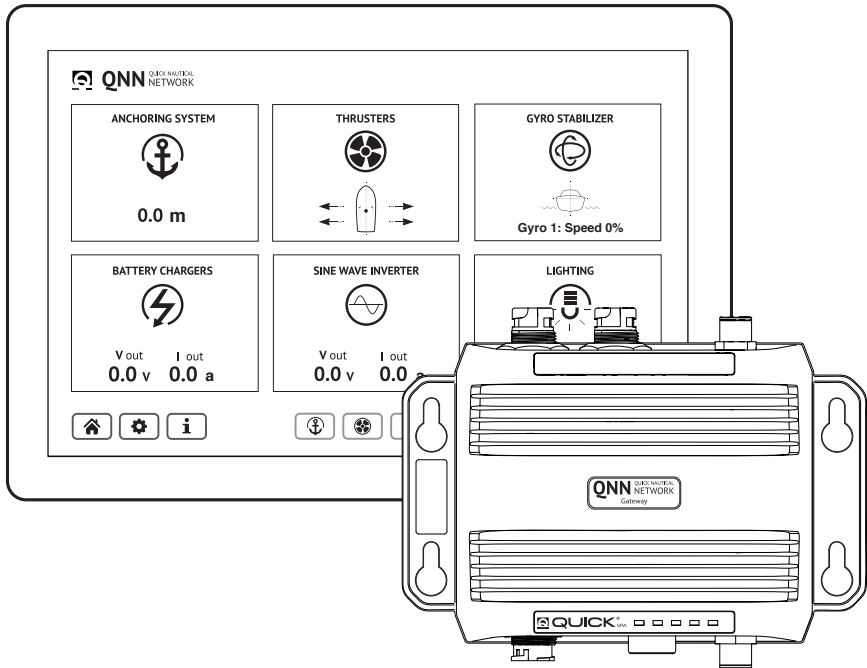

**GATEWAY**



<b>1 - Information about the product</b>	Pag. 5
1.0 - Description	Pag. 5
1.1 - Main features	Pag. 5
1.2 - Technical data	Pag. 6
<b>2 - Supplied parts</b>	Pag. 7
2.0 - Package contains the following parts	Pag. 7
2.1 - Required components, available for the QNN	Pag. 7
2.2 - Compatible accessories for use QNN	Pag. 7
<b>3 - General information</b>	Pag. 7
<b>4 - Safety</b>	Pag. 8
4.0 - Precautions	Pag. 8
4.1 - Warnings	Pag. 8
4.2 - Environmental requirements	Pag. 8
<b>5 - Installation procedures</b>	Pag. 9
5.0 - Gateway Installation	Pag. 9
<b>6 - Electrical connection</b>	Pag. 10
<b>7 - Functioning of the appliance</b>	Pag. 14
7.0 - Control Panel	Pag. 14
7.1 - LED specifications	Pag. 14
<b>8 - Installation on Chartplotter</b>	Pag. 15
8.0 - Installation Plug & Play	Pag. 15
<b>9 - Maintenance</b>	Pag. 15
<b>10 - Using the control interface</b>	Pag. 16
10.0 - Start QNN	Pag. 16
10.1 - Keys and functions	Pag. 16
10.2 - HOME page	Pag. 17
10.3 - Setup	Pag. 18
10.4 - Anchoring system	Pag. 19
10.5 - Thruster	Pag. 21
10.6 - Gyro Stabilazer	Pag. 22
10.7 - Battery Chargers	Pag. 23
10.8 - Lighting	Pag. 24
10.9 - lighting Configuration & modification	Pag. 25
<b>11 - Alarms &amp; Troubleshooting</b>	Pag. 26
11.0 - Alarms Troubleshooting	Pag. 26
11.0 - Troubleshooting	Pag. 26
<b>12 - Spare parts</b>	Pag. 26
<b>Dimensions Gateway</b>	Pag. 6





## 1.0 - Description

Quick Nautical Network Gateway allows the Quick systems to be integrated with the navigation systems.

Thanks to the QNN, the owner of a latest-generation chart plotter compatible with the HTML5\* protocol, will be able to monitor all Quick Spa devices installed on his boat using an intuitive interface that compiles all of the functions.

Compatible Quick accessories:

- Anchoring system
- Thruster
- Battery chargers
- Stabilazer MC<sup>2</sup> Quick Gyro
- Lighting

## 1.1 - Main features

- Management of Quick accessories
- Compact and practical design
- interface HTML5 for HMI web
- Plug-play installation
- 2 Ethernet port (WAN/LAN)
- 2 CAN bus port
- 1 USB host port
- Plug-in modules for expanding the system
- Solid and compact design with IPX7 degree of protection (front).



## 1.2 - Technical data

SYSTEM RESOURCES	
CPU	ARM Cortex-A8 300 MHz
OPERATING SYSTEM	Linux RT
FLASH	2 GB
RAM	256 MB
FRAM	64 KB
Real time clock - RTC Back-up	YES
INTERFACE	
Ethernet port	2 (port 0 - 10/100, port 1 - 10/100)
USB port	1 (Host v. 2.0, max. 100 mA)
Serial port	RS-485
CAN bus port	2 (optical isolation - 1kV)
LED indicators	5 (Power, Ethernet status)
RATING	
Supply	da 9 a 32 Vdc
Current absorption	0,15A max. at 24 Vdc
ENVIRONMENTAL CHARACTERISTICS	
Operating Temp	-15°C to +55°C
Storage temp	-20°C to +70°C
Umidità	5 - 85% RH, non-condensing
Protection Class	IPX7
GENERAL FEATURES	
Weight	280 g
CE	EN 60945, EMC Emissions and Immunity for marine applications

Dimensions in mm (inch)

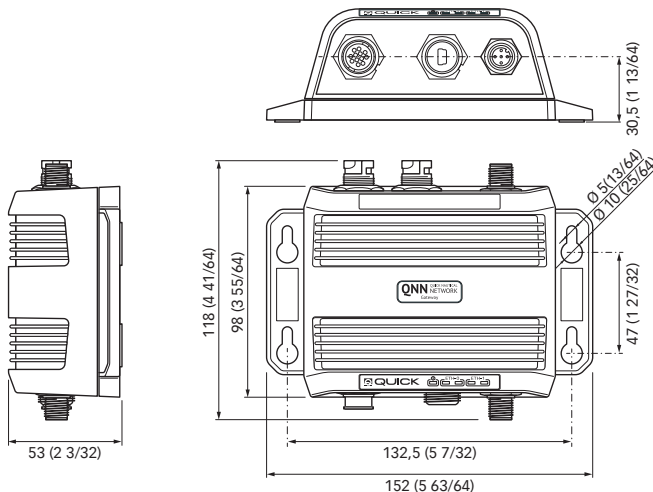

### 2.0 - Package contains the following parts

1 QNN Gateway  
1 Power cord (2m / 6,57 ft)  
1 Template to install  
1 INSTALLATION AND USE MANUAL  
The warranty

### 2.1 - Required components, available for the QNN

Garmin: Ethernet Cable QNN GTW 5P MM (2M 6,5ft), Adattatore 5P F RJ45 M (0,15M 0,5ft)  
Simrad: Ethernet Cable QNN GTW 5P MM (2M 6,5ft)  
Raymarine: Ethernet Cable QNN GTW 5P M RJ45 F (2M 6,5ft)  
Ethernet Cable QNN GTW-RC MC2 (2M 6,5ft)  
QNN ASH adapter SBC NRG+/HSI

### 2.2 - Compatible accessories for use QNN

Garmin display [www.garmin.com](http://www.garmin.com)  
Raymarine display [www.raymarine.com](http://www.raymarine.com)  
Simrad display [www.simrad-yachting.com](http://www.simrad-yachting.com)

This document contains the instructions that are necessary for boat manufacturers and marine equipment installers to assemble and commission the **GATEWAY - QUICK NAUTICAL NETWORK - QNN Quick®**.

## 3 - General information

This device was designed and constructed for use on recreational crafts.  
Other forms of use are not permitted without written authorization from the company Quick®.

Quick® Gateway QNN has been designed and constructed for the purposes described in this instruction manual.

The "Quick®" Company does not accept any responsibility for direct or indirect damage caused by improper use of the equipment, bad installation or by possible errors occurring in this manual.

This device must not be used by people (including children) with reduced physical, sensory or mental abilities.



**ANY TAMPERING WITH THE QNN GATEWAY BY UNAUTHORIZED PERSONS ANNULS THE GUARANTEE.**

In case of discordance or errors in translation between the translated version and the original text in the Italian language, reference will be made to the Italian text.



**BEFORE USING THE GATEWAY QNN CAREFULLY READ THIS USER'S MANUAL. IF IN DOUBT, IMMEDIATELY CONTACT YOUR NEAREST AUTHORISED QUICK® DEALER.**

## 4.0 - Precautions

- Comply with all the safety warnings included in this manual.
- Comply with all the technical parameters indicated in this manual.
- Handle with care paying attention to avoid damaging the gyro or getting injured.
- Strictly observe all the local accident prevention standards during both assembling and regular operation.
- Maximum cleanliness must be guaranteed during operations.

## 4.1 - Warnings



• **The QNN operates within 90=32 Vac power supply**  
**Connect to the electrical line in compliance with the protection standards in force.**



• **During navigation, we recommend not disconnecting the power supply to prevent damages to the connected products.**



• **DO NOT** open the device case.  
• **DO NOT** introduce foreign objects inside the protection cover.



• Before performing any operation, such as **cleaning or a update software**, in order to prevent any damage to people or objects caused by an accidental start-up. Disconnect the **Gateway QNN from the power supply.**



• Restore the power supply only after having correctly installed all the safety devices that were removed to carry out the operations.

### CLEANING THE APPLIANCE

- **DO NOT USE** solvents or fuels to clean the appliance.
- **DO NOT REMOVE** the safety labels on the equipment.



**Do not use this product as a primary navigation instrument. The operator is responsible for the use of the accessories on the QNN and prudent methods for safe navigation.** The software contained in the QNN could change without notice or may not be updated. The alarms refer to the use of the individual connected accessories and to the use of the QNN



You are aware and accept to be the only persons responsible for use of the QNN and all decisions taken as a result. In using this service, you free Quick SpA and waive presenting any claims in relation to this service.



The QNN does not replace standard navigation practices and must not be used as single sources of reference. The QNN is only a navigation aid and must be used along with approved methods for safe navigation. The captain of the ship is always responsible for the course correction.



All navigation aids are subject to inaccuracies and discrepancies that, if not taken into consideration, can cause accidents and problems and, consequently, the loss of life or serious injuries.

## 4.2 - Environmental requirements

We recommend positioning the stabilizer in a dry, ventilated place in order to enable it to operate at full power and be protected from atmospheric agents.

Make sure that the installation location is suitable for correct installation and easy inspection.





## 5.0 - Gateway Installation

The installation of one single appliance can be carried out in any area of the boat, taking into account the following necessary indications for the correct operation of the appliance: A typical installation procedure is described below. It is not possible to define a single procedure that is applicable in every situation.

Adapt the procedure described here to your own requirements.

Identify the most appropriate position for the appliance seating on the basis of the following criteria:

- The appliance must be positioned so that it can easily be reached by the operator.
- Choose a clean, smooth, flat location.
- The fastening points should be on a level surface.
- The holes must not weaken or cause the breakage of structural elements of the boat.
- Place the appliance at least: 25 cm / 9,85 in from the bush - 50 cm / 19,69 in from all radio receiving device - 1 m from all radio transmitting device - 2 m / 78,74 in from the radar beam path.
- The IP protection rating is guaranteed on the Gateway cases and wired connectors. We recommend closing unused connectors to prevent infiltrations of water, humidity, or seawater that could damage or oxidize part of the instrument.

After choosing where to position the instrument, proceed as follows:

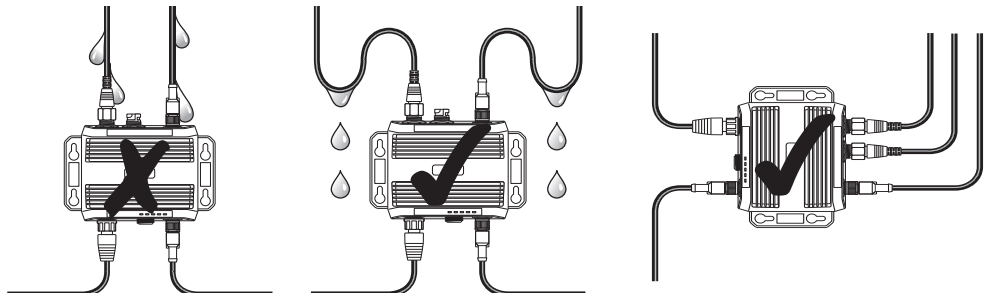
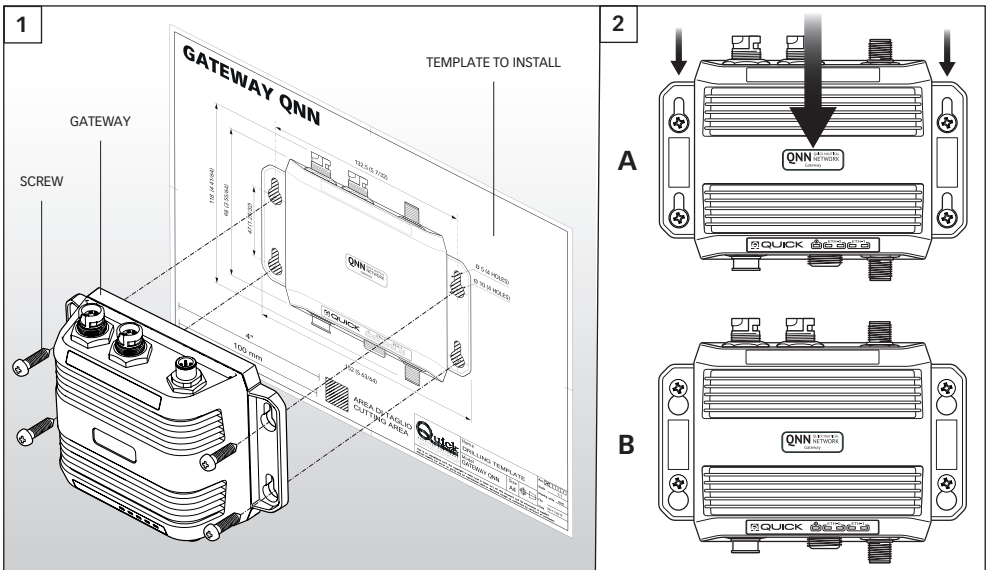

## CONNECTION OF GATEWAY QNN

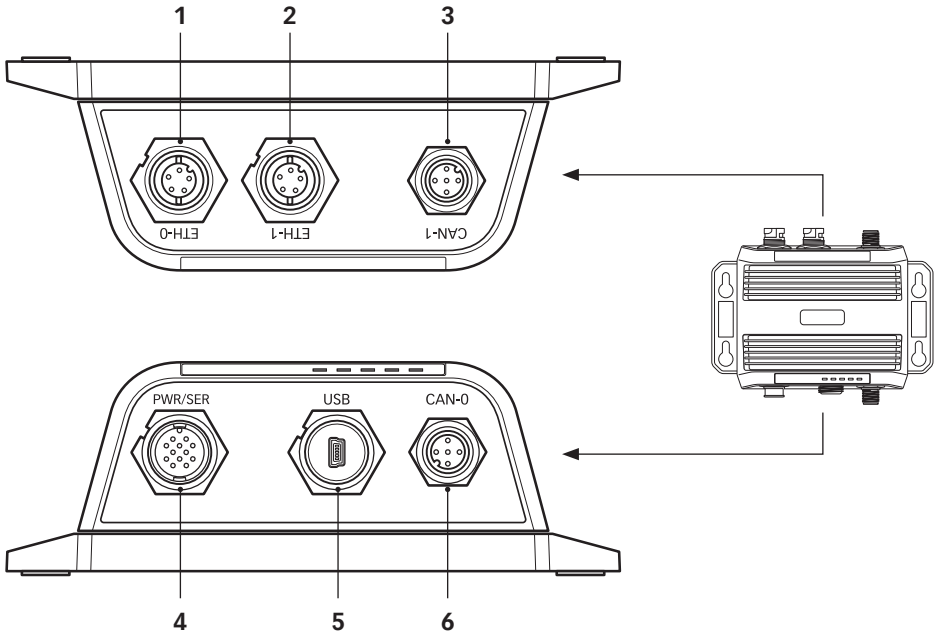

<b>1</b>	ETH-0 PORT	CHARTPLOTTER IN DHCP	<b>4</b>	SERIAL PORT	SUPPLY - MODBUS
<b>2</b>	ETH-1 PORT	GYRO STABI	<b>5</b>	USB PORT	SOFTWARE UPGRADE
<b>3</b>	CAN-1 PORT	CHC, SRC NRG+, INVERTER	<b>6</b>	CAN-0 PORT	PCS SYSTEM, ANCHORING SYSTEM, THRUSTER

## ALIMENTAZIONE

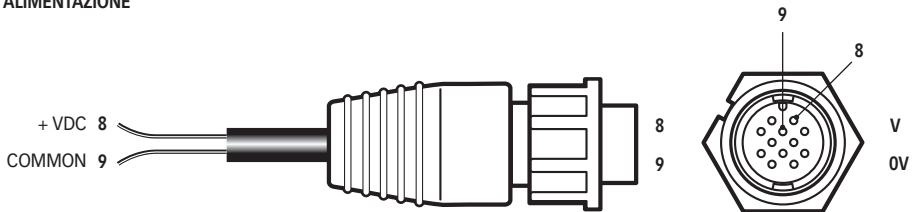

Very low voltage safety power supply unit. Limited power source. Do not open the panel casing when devices are live.

## CONNECTIONS

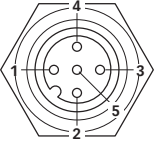

PIN	DESCRIPTION
1	SHIELD
2	-
3	GND
4	CAN-H
5	CAN-L

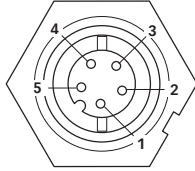

PIN	DESCRIPTION
1	TX+
2	TX-
3	RX+
4	RX-
5	SHIELD

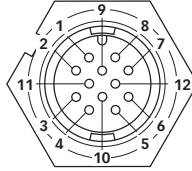

PIN	DESCRIPTION	COLOR
1	RTS/TX+ 1	BROWN
2	TX- 1	BLUE
3	CTS/RX+ 1	WHITW
4	RX- 1	GREEN
5	RX- 2 <i>NOT INCLUDED</i>	YELLOW
6	CTS/RX+ 2 <i>NOT INCLUDED</i>	GREY
7	TX- 2 <i>NOT INCLUDED</i>	PINK
8	+ VDC	RED
9	GND	BLACK
10	ISOLATED GND 1	LIGHT GREEN
11	RTS/TX+ 1 <i>NOT INCLUDED</i>	PURPLE
12	I. GND 2 <i>NOT INCLUDED</i>	ORANGE

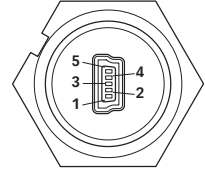

PIN	DESCRIPTION
1	VCC
2	D-
3	D+
4	-
5	GND

## CONNECTION INDICATIONS

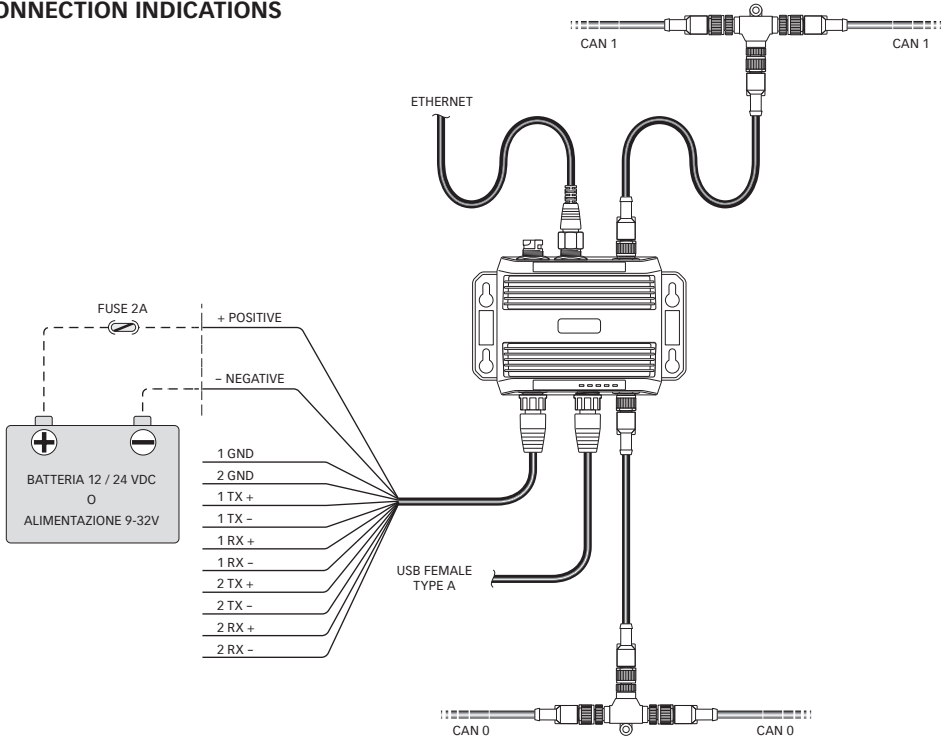

## CONNECTION EXAMPLE

QNN gateway - plant description

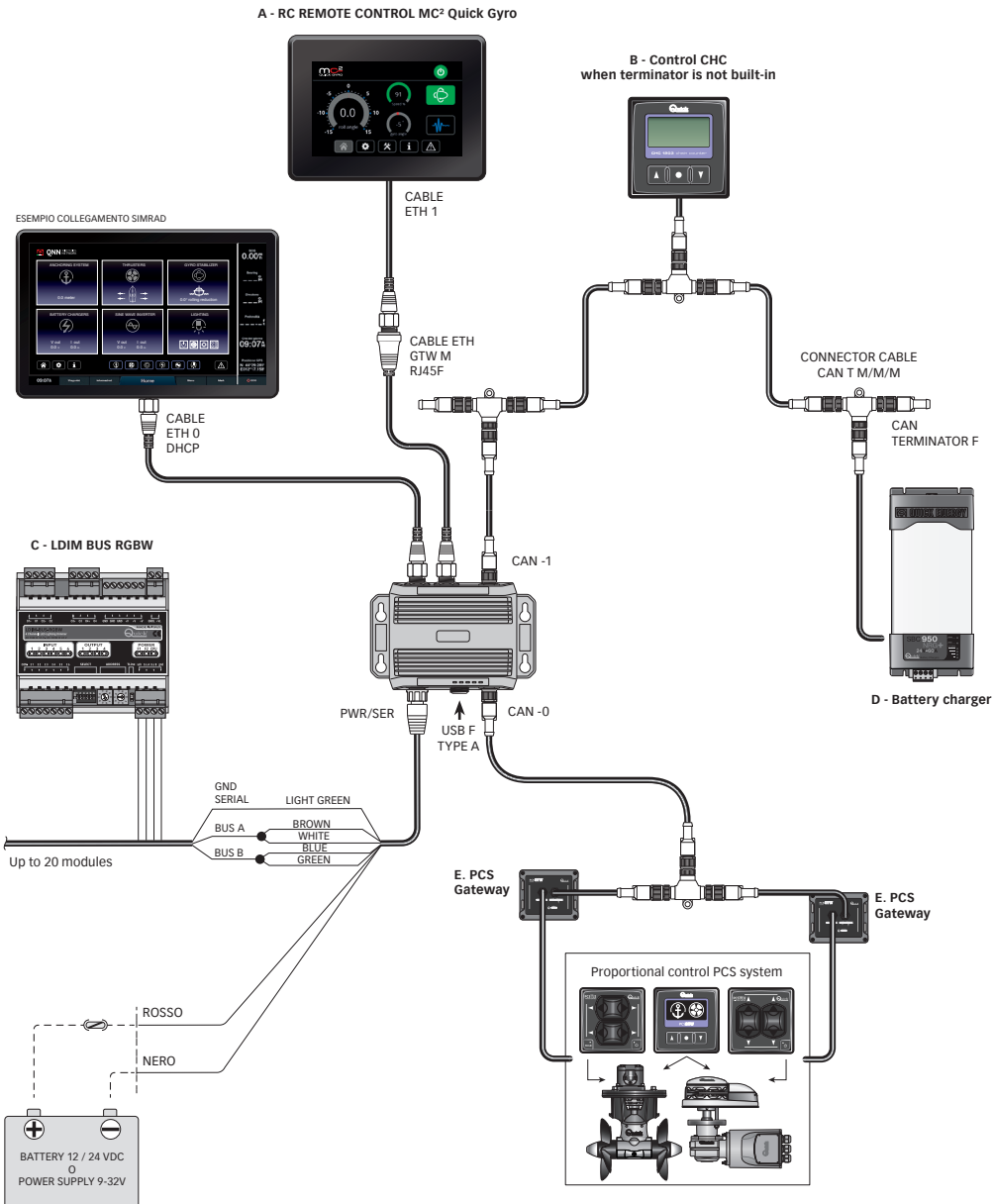

## Electrical connection of accessories

For the electrical connection of accessories, refer to the dedicated manuals.

**A - Remote control panel MC<sup>2</sup> Quick Gyro:** Manual REMOTE CONTROL PANEL

**B - Control CHC:** Manual Chain counter CHC

**C - LDIM BUS RGBW:** Manual Led dimmer LDIM BUS RGBW

**D - Battery charge:** Manual SBC NRG + Medium e High Power

**E - PCS Gateway:** Manual PCS NCG - T (Gateway Thruster) / PCS NCG - W (Gateway windlass)

## Example of the electrical connection of the compatible chart plotters

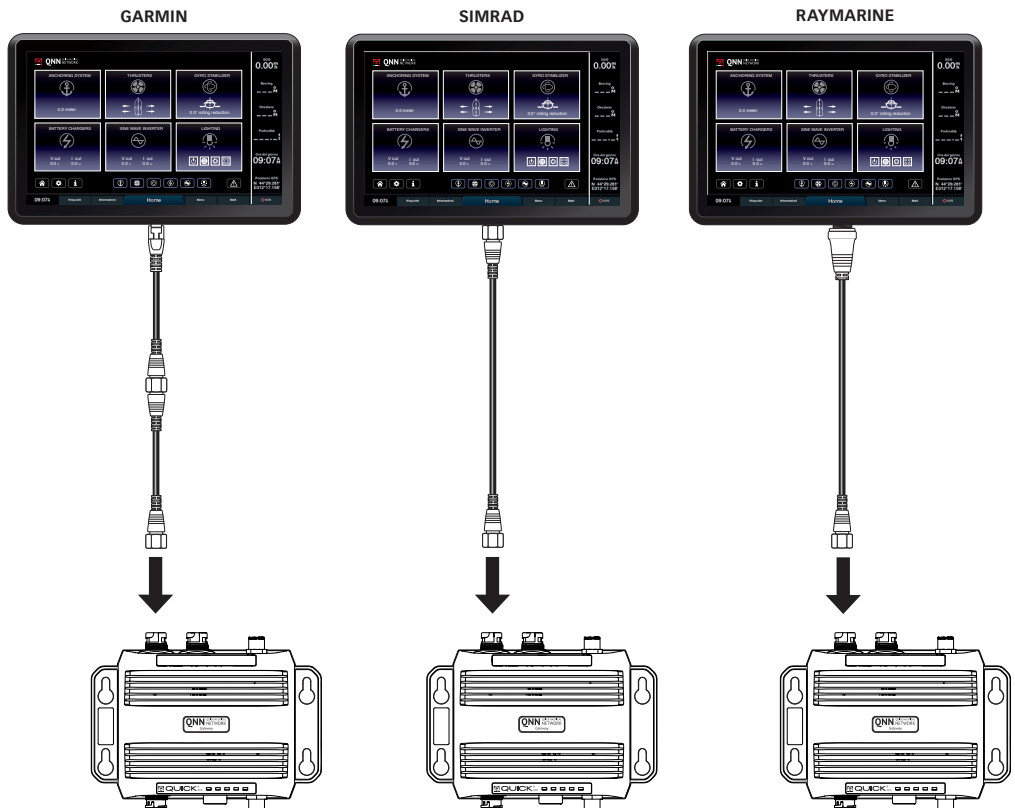





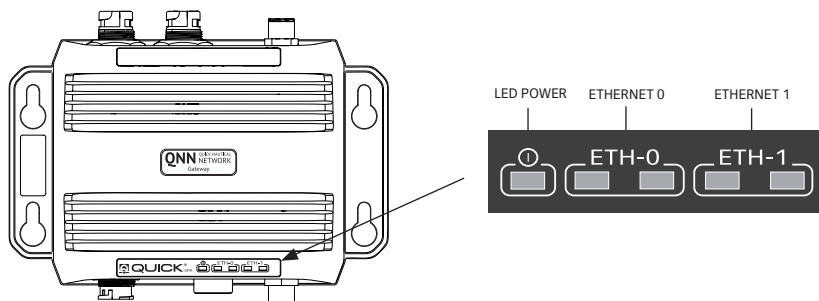





## 7.0 Control Panel

The control panel is composed of 5 LEDs:  
1 POWER LED, 4 LEDs with ETHERNET connection



## 7.1 LED specifications

LED POWER	GREEN	LED STATUS	DESCRIPTION
		OFF GREEN OFF	NO POWER
		ON GREEN ON	OPERATING MODE - OPERATION COMPLETED SUCCESSFULLY
		GREEN FLASHES SLOWLY	ERROR DURING THE LAST OPERATION
		GREEN FLASHES QUICKLY	OPERATION IN PROGRESS

ETHERNET 0 - ETHERNET 1	GREEN	RED	LED STATUS	DESCRIPTION
			GREEN OFF RED OFF	NO CONNECTION
			GREEN FLASHES RED STEADY	CONNECTED

## 8.0 Installation Plug & Play

After completing the electrical connections, just connect the Gateway to the Chart plotter. Thanks to the plug & play system, all of the calibrations made on the Quick products' systems or from the chart plotter are automatically shared between the two systems (Quick and chart plotter). The chart plotters suitable for the QNN Gateway are the latest generation ones with HTML5.

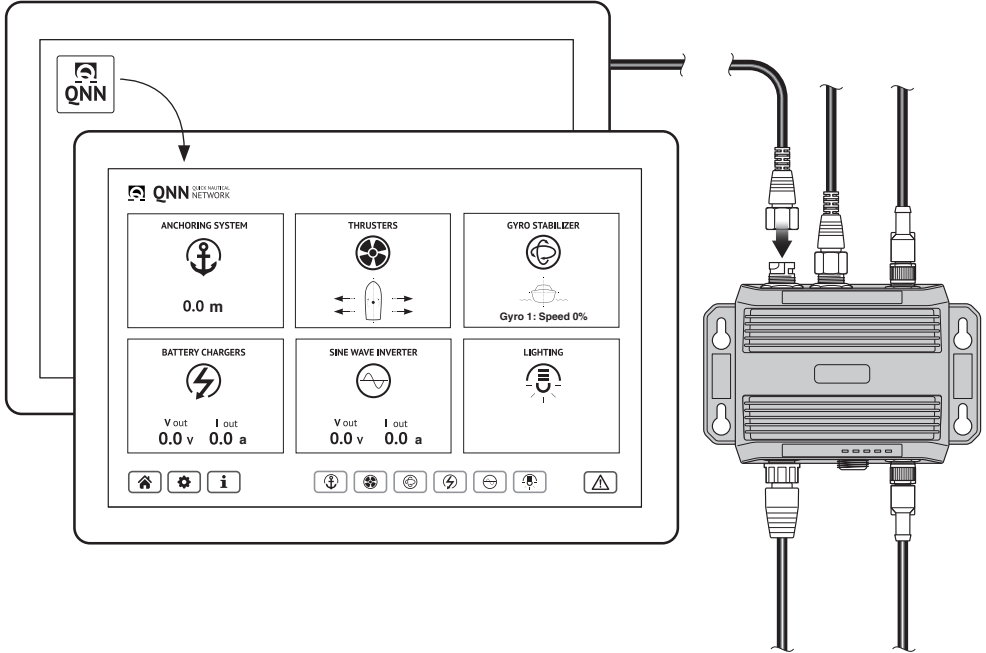

## 9 - Maintenance

The QNN gateway needs no particular maintenance. Clean the device with a soft cloth dampened with water. Do not use chemical or abrasive products.

**Battery type**

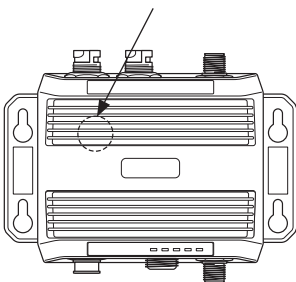

### BATTERY DISPOSAL



Dispose of the batteries according to local legislation.



- Use of the QNN interface does NOT replace the control panels dedicated to the Quick products. The interface must be used with full knowledge of the facts and to facilitate the functions of the connected Quick products.
- If bugs are encountered in the QNN interface, use the specific control panels for each product.

## 10.0 - Start QNN



QNN ICON

After performing the installation procedure, including the electrical connection of the Quick products, the QNN icon will appear on your Chart plotter screen. Pressing it opens the programme and you can start using it right away.

## 10.1 - Keys and functions

The functions of the QNN described are only available for products **Quick®**.

The interface must be used to switch on the **Quick®** compatible products.  
The Gateway QNN must be connected to the interface inlets through clean contacts.

- The product(s) to activate through the interface must be previously installed and connected to the mains or the battery.

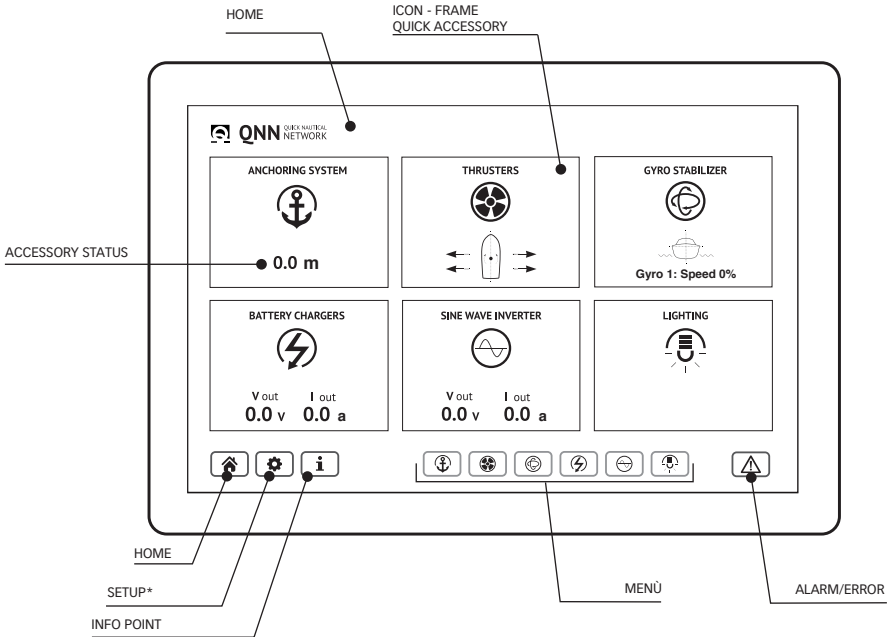

To make instructions easier, all functions and symbols are indicated in the figure. However, while using the device, the display only shows the icons and display areas relative to the connected functions. The detailed instructions for use can be found in the following.

\*In "Home" it shows the general settings; in each page it shows the settings for the page shown





## 10.2 - HOME page

HOME is the main page, where real-time data is displayed, relating to the products connected in the active / inactive phase.

The Quick accessories that can be applied to the QNN are:

Windlass - Thrusters - Gyroscopic Stabilizers - Battery Charger - Inverter (currently not available) - Lights

### ACTIVE AND INACTIVE ICONS

Home shows the Quick accessories that are connected and not connected. If they are not connected, the icon for the accessory will be visible but inactive (GHOST).

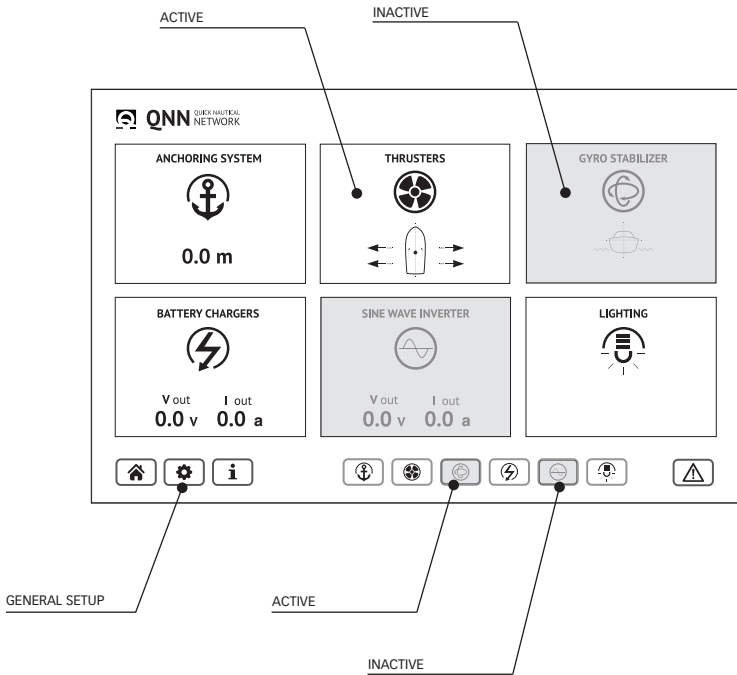



## 10.3 - General Setup

\*SETUP - General QNN setup page

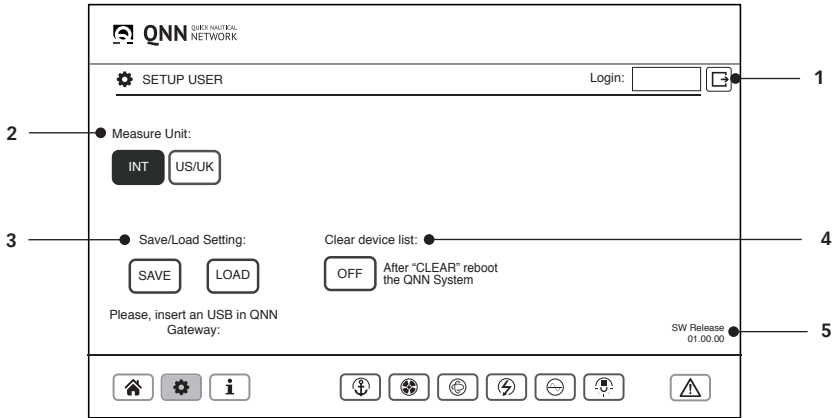

NR	DESCRIPTION	OPERATION
1	Login	Access restricted to Quick® technicians for advanced settings
2	Measure Unit	Choose the unit of measure
3	save/load setting	Backup. Use a formatted USB drive (to perform the backup, insert the drive and press SAVE. The backup was successful if the folder is found on the drive)
4	Clear device list	Reload the driver
5	SW Release	software release version

## 10.4 - Anchoring system

**ANCHORING SYSTEM** - Quick chain counter/windlass rope management page.  
 Ability to weigh and drop anchor, Quick control panels can be connected to the PCS family version 62.37 and the CHC version 2.15 and later (for use and installation of the control panels, refer to the dedicated manuals).

The QNN may not be used as a single manoeuvring instrument but must be associated to its primary control panels.

### CHC CONNECTION - Ability to manage one windlass.

The CHC command must be set with a CAN speed of 125 Kbps. Refer to the CHC 1203 manual..

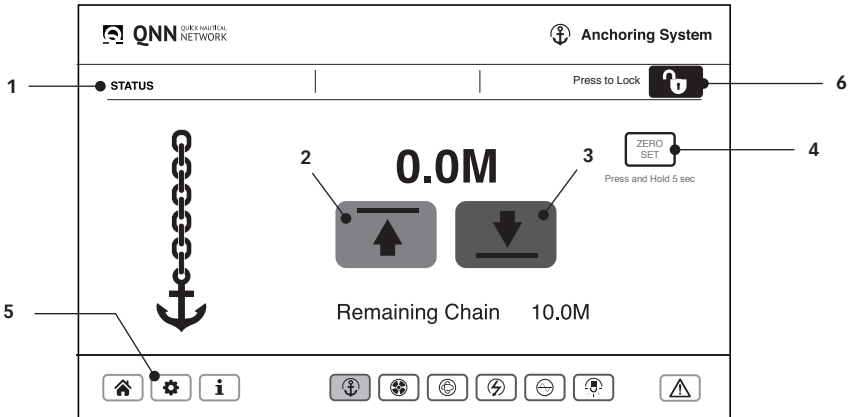

### PCS CONNECTION - Ability to manage one or two windlasses

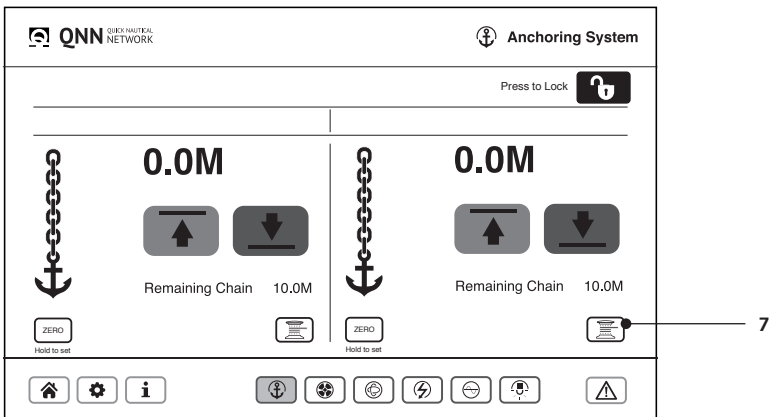



WARPING MODE - ACTIVE ONLY WITH PCS

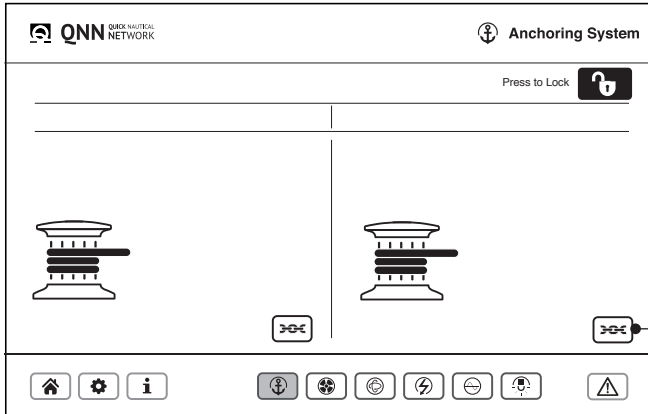

NR	DESCRIPTION	OPERATION
1	Status	This area shows messages related to the status of the instrument.
2	Raise chain key (Red)	Hold down the key to raise anchor
3	Drop chain key (Green)	Hold down the key to drop anchor
4	Zero set key	Reset the measure of chain lowered. This option is to be used during installation or when the chain counter's reading does not match the actual length of the chain lowered.
5	Setup Anchoring	1. Setting for choice of meters of chain to use. 2. Time out: Automatic disablement with command enabled. The time out occurs after the time set in the time out parameter since the last command was executed (default 10 minutes).
6	Block functions key	Command Enable and Block key (hold down to block or unblock the control).
7	Capstan	Key to pass to warping mode, use (external) commands.
8	Chain	Key to pass to windlass mode



It is possible to weigh/drop the anchor using the Quick electric commands; the QNN will measure the length of the chain dropped.

## 10.5 - Thruster

**THRUSTER SYSTEM** - Quick thruster management page. Ability to manoeuvre the boat, Quick control panels can be connected to PCS from version 60.37 (for use and installation of the control panels, refer to the dedicated manuals).



The QNN may not be used as a single manoeuvring instrument but must be associated to its primary control panels.

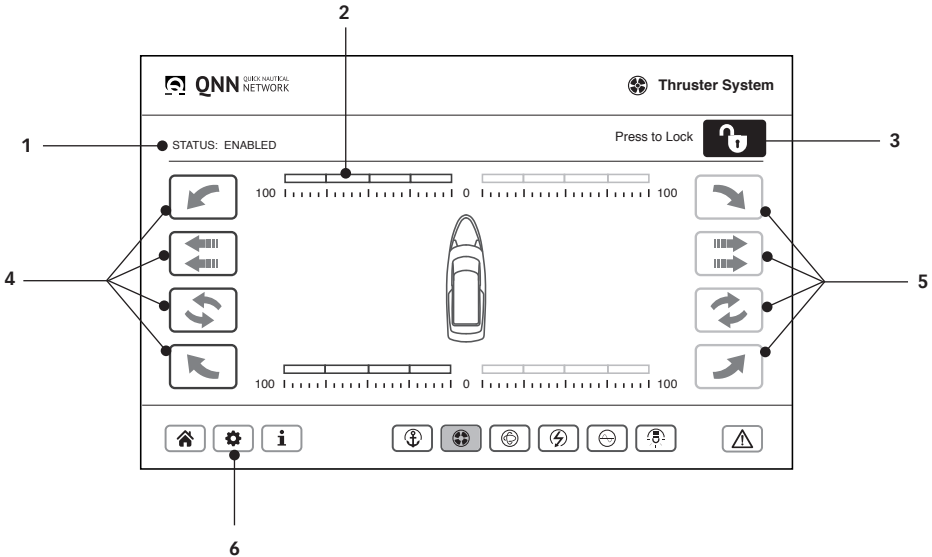

NR	DESCRIPTION	OPERATION
1	Status	Enabled or disabled functions
2	Manoeuvring keys with proportional control	Proportional power manoeuvring control keys, choice of 25%, 50%, 75%, and 100% power, possible only with L/R bow rotation and L/R stern rotation keys
3	Block functions key	Command Enable and Block key (hold down to block or unblock the control)
4	Left Manoeuvring Key (Red)	Manoeuvring keys: Left Bow rotation - Left side movement - Complete Left Rotation - Left Stern rotation
5	Tasto Manovra DX (Verdi)	Manoeuvring keys: Right Bow rotation - Right side movement - Complete Right Rotation - Right Stern rotation
6	Setup Thruster	Time out: Automatic disablement with command enabled. The time out occurs after the time set in the time out parameter since the last command was executed (default 10 minutes).



## 10.6 - Gyro stabilizer

**GYRO STABILIZER** - Quick stabilizing monitoring Mirroring page

In the MC<sup>2</sup> Quick Gyro page, the functions of the Remote MC<sup>2</sup> Quick Gyro panel functions are mirrored.

It is possible to access the commands to turn the stabilizer(s) on/off, and to display its(their) status and correct operation

To use the command, refer to the RC - Remote Control MC<sup>2</sup>X - Quick manual

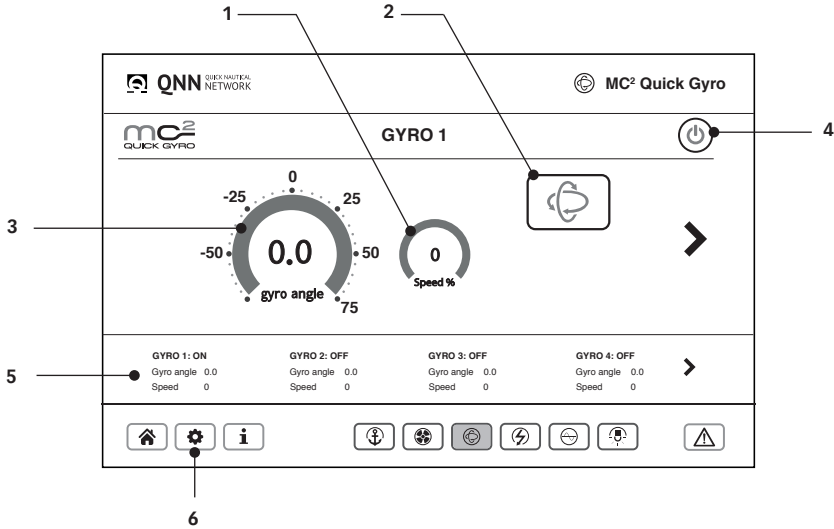

NR	DESCRIPTION	OPERATION
1	Speed	Nominal speed (not present in the x2 and x3)
2	Precession	Key to activate and deactivate the precession (not present in the x2 and x3)
3	Gyro Angle	Precession angle
4	ON/OFF Button	Key to turn on the gyroscope if single / gyroscopes with the multi-stabilizer option
5	Gyro sliding bar	List of connected gyros and status display
6	Setup Gyro	For the settings, use the Setup function on the dedicated

**More information** - Manual RC MC<sup>2</sup> QUICK GYRO

## 10.7 - Battery chargers

**BATTERY CHARGERS** - Quick battery charger monitoring page Management of several battery chargers at the same time.

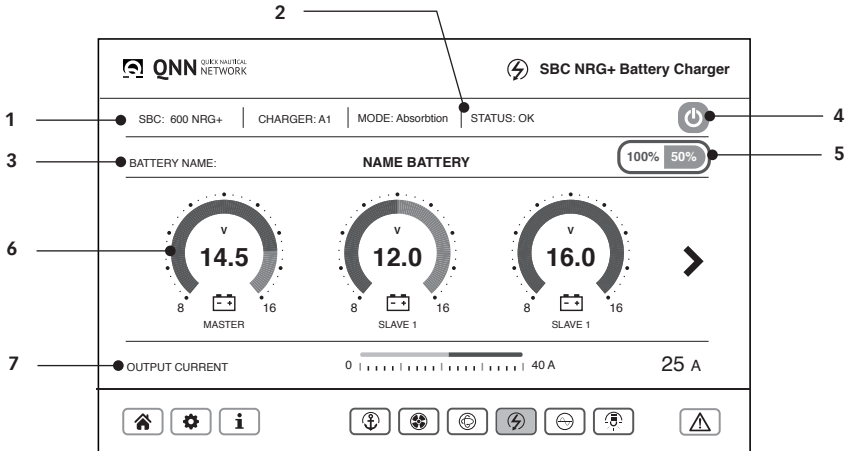

NR	DESCRIPTION	OPERATION
1	Status	Indication of the battery charger status
2	Mode	Charging characteristics: Float - Absorption - Bulk -> Charging phase (Float - Absorption - Bulk)
3	Battery Name	Custom name of the charged battery group
4	ON/STAND BY - Button	Switching on and/or standby key
5	Power	Ability to reduce the maximum current of the battery charger by 50%
6	Output Current - Gauge	Battery voltage indicator
7	Output Current	Battery charger current delivered
8	Setup Charger	Ability to change the name of the batteries



## 10.8 - Lighting

**LIGHTING** - Management page of the Lighting Quick products.

Switching on/off of lights and colour/tone management. Follow the configuration procedure on page 24, chapter 10.7.



Lighting home button

Activation of Lighting function. When the QNN is installed or updated, the key representing the lighting function in the HOME screen will appear inactive (GHOST). To activate it, hold down the lighting key until it activates it

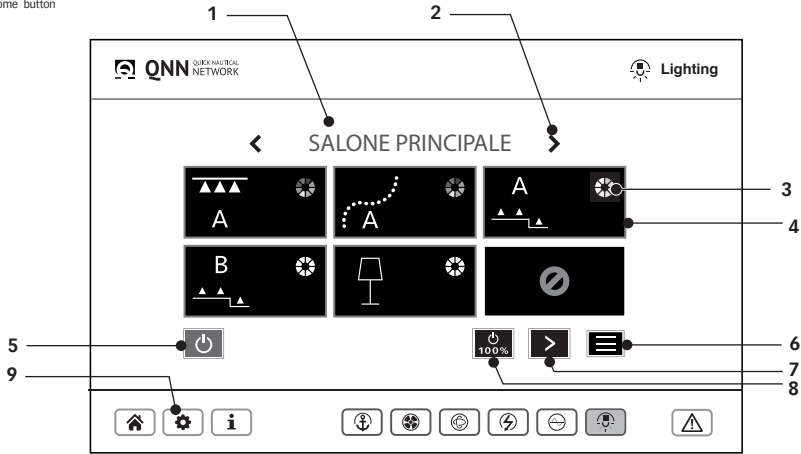

NR	DESCRIPTION	OPERATION
1	Light room	internal or external compartment, room or cabin featuring lighting equipment grouped in one or more luminous zones, identified by a name defined by the user.
2	Arrow keys	Display of the environments created (Ability to create a maximum of 10 environments)
3	Light source	Ability to manage the chosen light source type: <ul style="list-style-type: none"> <li>RGB (Coloured): Management of colour bar and Zone light intensity Dimmer</li> <li>DYNAMIC white (Light Yellow) Colour Temperature and Dimmer management.</li> <li>MONOCHROMATIC (White) Dimmer management</li> </ul>
4	Digital button	command button that appears on the Command Home page at the end of zone association operation.
5	Power/OFF (orange)	By keeping this button pressed for 2 seconds, all zones are simultaneously turned OFF.
6	Menù functions	This button allows accessing the MENU functions: 1. Extra: access to further settings. 2. All the lights in all environments will be turned OFF.
7	Zone Button	To display the other light areas present in the environment (max 12 areas)
8	Power 100% (green)	By keeping this button pressed for 2 seconds, all zones are turned ON at maximum power.
9	Setup Lighting	Ability to configure and change environments, areas, and lights. (Ref. page 24 Chap 10.6).

**More information** - LDIM Manual for connections





## 10.9 - Configuration & Modification Lighting

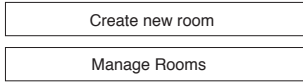

### 1. Creation / modification of the room

New room, selection: Create new room  
change room, selection: Manage Rooms

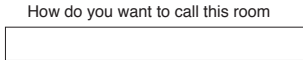

### 2. Room creation

Create a new room by naming it using the digital keyboard (e.g., MAIN SALOON, KITCHEN, BATHROOM, HALL, etc.). Confirm by pressing "OK".



### 3. Button selection

Select a Find zone box using the digital buttons, (the selected box will have a white frame).

You can select the Find zone boxes in the order you prefer.

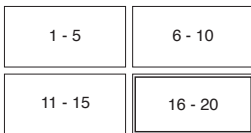

### 4. Searching zone

Select a range of zones (es. 16-20). Check to see if the lights in the area are flashing.

If the area responds, confirm by pressing "OK".

If the lights prompted do not flash, try searching for other groups of zones (1-5 • 6 -10 • 11-15 • 16-20).



### 5. Searching zone

Select a zone (es.20)

Check to see if the lights in the area are flashing. If the area responds, confirm by pressing "OK".

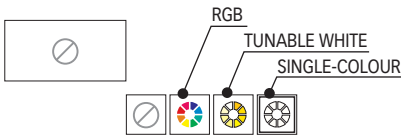

### 6. Selection of light source type

Select the light source type (es. single-colour).

*If the type of light source is not known, visually check how the lighting equipment of the identified area function. the selection is binding because the area management page changes according to the type of light source. Pay attention to the selection.*

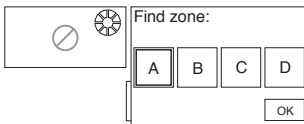

### 7. Selection of light source type

Based on the type of source chosen, there are different options - Choice of source outputs (control unit)

**RGB** - Nobody

**Tunable White** - Selection "zone" A o B

**Single-colour** - Selection "zone"

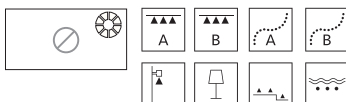

### 8. Device category selection

Select the icon of the lighting category. Options:

**Downlight A, Downlight B, Linear A, Linear B, Applique, Table light, Courtesy, Underwater.**

The selected box will have a green frame.



## 11.0 - Alarms

Alarm icon

The Alarm signal is present in all screens of the device; it only turns on in case of error or danger, and the type of error can be identified by clicking on the icon when it flashes.

If the alarm icon is red and starts flashing, click to see the error.  
Refer to the dedicated manuals for the nature of the error (explanation)

## 11.1 - Troubleshooting

### GENERAL

#### INTERFERENCE - UNEXPECTED BLOCK

If the software has an unexpected interference/block, follow the procedures below:

1. Clean the driver using the Clear Device List key in the main menu on the home screen (ref. page 17).  
Path: Home > Menu > Clear device list
2. If the problem persists, turn the QNN off and back on.
3. If the problem is not resolved, contact the Quick® customer service for support

#### GYRO STABILIZER

If the Remote Controls on the stabilizer cannot communicate with the QNN, make sure the IP address on the RC (remote controls) is different than the one in the QNN.

If the two addresses are identical, contact Quick® customer service for assistance.

Remote Controls IP address path: Home > Info > Display IP (for more information, consult the manual)

QNN IP address path: Home > Info > Display IP (ref. page 17)

If the problem persists, turn the QNN off and back on.

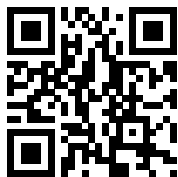

For the specific use of the Quick commands/accessories, scan the QR code to access the dedicated manuals.

- **Anchoring System:** 1203 series CHC, PCS ncg - w commands
- **Thruster:** PCS Gateway
- **Gyro Stabilizer:** MC² X - Remote Control Panel
- **Battery Chargers:** SBC NRG+ Medium and High power
- **Lighting :** LDIM - Electrical connections (NOT AVAILABLE ONLINE AT THIS TIME)

## 12 - Spare parts

CODE	DESCRIPTION
FCQNNGTWRM00A00	QNN CRA CABLE QNN GTW-RAYMARINE
FCQNNGTWNV00A00	QNN CNA CABLE QNN GTW-NAVICO
FCQNNGTWGR00A00	QNN CGA CABLE QNN GTW-GARMIN
FCQNNNAUS0000A00	QNN AUS CONNECTOR CABLE USB
FNQNNRJ45M12A00	QNN ASH CONNECTOR CABLE SBC NRG+/HSI
FCQNNGTWRCM0A00	QNN CRC CABLE QNN GTW-RC MC2X



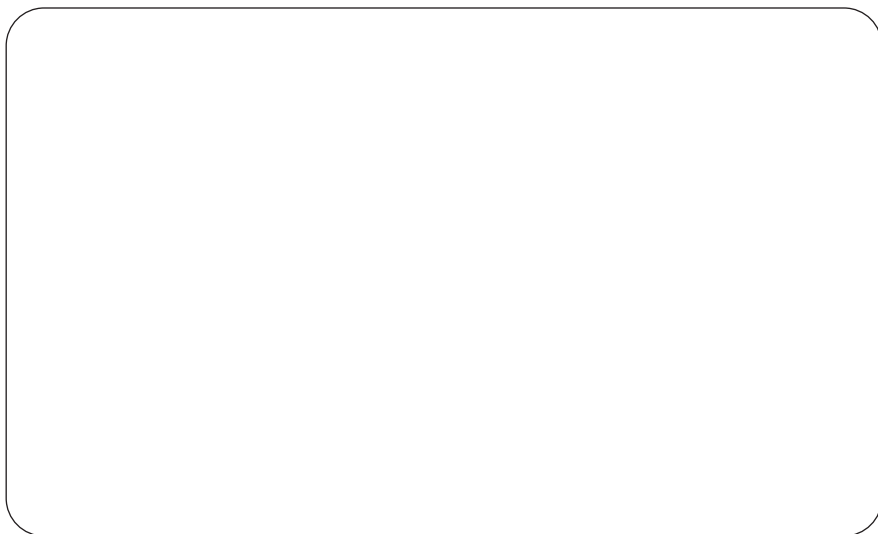

Product serial code