

# **FURUNO**

## **OPERATOR'S MANUAL**

*GPS RECEIVER*

Model **GP-330B**

---

Part no. 17-468-01 rev. 10



# IMPORTANT NOTICES

---

## General

- This manual has been authored with simplified grammar, to meet the needs of international users.
- The operator of this equipment must read and follow the descriptions in this manual. Wrong operation or maintenance can cancel the warranty or cause injury.
- Do not copy any part of this manual without written permission from FURUNO.
- If this manual is lost or worn, contact your dealer about replacement.
- The contents of this manual and equipment specifications can change without notice.
- The example screens (or illustrations) shown in this manual can be different from the screens you see on your display. The screens you see depend on your system configuration and equipment settings.
- Save this manual for future reference.
- Any modification of the equipment (including software) by persons not authorized by FURUNO will cancel the warranty.
- The following concern acts as our importer in Europe, as defined in DECISION No 768/2008/EC.
  - Name: FURUNO EUROPE B.V.
  - Address: Siriusstraat 86, 5015 BT, Tilburg, The Netherlands
- The following concern acts as our importer in UK, as defined in SI 2016/1025 as amended SI 2019/470.
  - Name: FURUNO (UK) LTD.
  - Address: West Building Penner Road Havant Hampshire PO9 1QY, U.K.
- All brand and product names are trademarks, registered trademarks or service marks of their respective holders.

## How to discard this product

Discard this product according to local regulations for the disposal of industrial waste. For disposal in the USA, see the homepage of the Electronics Industries Alliance (<http://www.eiae.org/>) for the correct method of disposal.

## How to discard a used battery

Some FURUNO products have a battery(ies). To see if your product has a battery, see the chapter on Maintenance. Follow the instructions below if a battery is used. Tape the + and - terminals of battery before disposal to prevent fire, heat generation caused by short circuit.

### In the European Union

The crossed-out trash can symbol indicates that all types of batteries must not be discarded in standard trash, or at a trash site. Take the used batteries to a battery collection site according to your national legislation and the Batteries Directive 2006/66/EU.

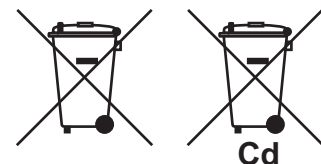

### In the USA

The Mobius loop symbol (three chasing arrows) indicates that Ni-Cd and lead-acid rechargeable batteries must be recycled. Take the used batteries to a battery collection site according to local laws.

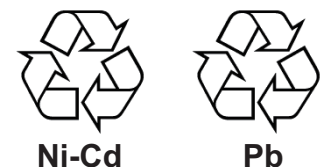



### In the other countries

There are no international standards for the battery recycle symbol. The number of symbols can increase when the other countries make their own recycle symbols in the future.







# SAFETY INSTRUCTION







The operator of this equipment must read these safety instructions before attempting to operate the equipment.

 <b>WARNING</b>	Indicates a potentially hazardous situation which, if not avoided, could result in death or serious injury.
 <b>CAUTION</b>	Indicates a potentially hazardous situation which, if not avoided, may result in minor or moderate injury.

 Warning, Caution	 Prohibitive Action	 Mandatory Action
--	--	--

 <b>WARNING</b>
 <b>Always wear safety goggles and a dust mask when installing to avoid personal injury.</b>

 <b>CAUTION</b>
 <b>The input voltage shall be 12 - 24 VDC.</b> Any other input voltage can damage the equipment.
 <b>Make power connections to a 12 - 24 VDC power source that is isolated from the engine start battery(s).</b>  Voltage drop may cause the GPS receiver to lose information and/or change operating mode.
 <b>A safe installation requires a 0.5 amp fast-blow fuse or circuit breaker.</b>

 <b>CAUTION</b>
 <b>Do not disassemble the unit.</b>  Disassembling the unit will damage the waterproof seal. Further, there are no user-serviceable parts inside.
 <b>GPS position and velocity accuracies are controlled by the U.S. Department of Defense. Therefore, the position accuracy described in the specifications cannot be guaranteed.</b>
 <b>No one navigation device should ever be solely relied upon for the navigation of a vessel.</b>  Always confirm position against all available aids to navigation, for safety of vessel and crew.
 <b>The compass safe distance for standard and steering compasses is 0.30 m.</b>  Observe this distance to prevent interference to a magnetic compass.
 <b>Do not use high-pressure cleaners to clean this equipment.</b>  This equipment has the waterproof rating outlined in the specifications, at the back of this manual. However, the use of high-pressure cleaning equipment can cause water ingress, resulting in damage to, or failure of, the equipment.

# TABLE OF CONTENTS

---

**Note:** This manual contains both English and Japanese instructions. The Packing Lists, Outline Drawings, and Interconnection Diagram are located at the back of this manual.

<b>FOREWORD</b> .....	<b>iv</b>
<b>SYSTEM CONFIGURATION</b> .....	<b>v</b>
<b>1. INSTALLATION</b> .....	<b>1</b>
1.1 Equipment Lists .....	1
1.2 Tools & Materials.....	1
1.3 Choosing the Mounting Location .....	2
1.4 Mounting.....	3
1.4.1 Pole/Rail (Pipe) Mount .....	3
1.4.2 Deck Mount.....	4
1.4.3 Flush Mount (Optional kit GP-330B-FLUSH KIT (code no.: 001-037-630) required.) .....	5
<b>2. WIRING, SETTINGS</b> .....	<b>6</b>
2.1 CAN bus Connection (Type A or N) .....	6
2.1.1 Direct Connection.....	6
2.1.2 Network Connection.....	7
2.1.3 Routing and Connecting the Cable Assembly.....	8
2.2 NMEA 0183 Connection (Type B or N) .....	9
2.3 Settings for NavNet vx2.....	10
<b>3. MAINTENANCE, TROUBLESHOOTING</b> .....	<b>11</b>
3.1 Maintenance.....	11
3.2 Troubleshooting.....	11
<b>4. TECHNICAL INFORMATION</b> .....	<b>12</b>
4.1 NMEA 0183 Sentences .....	12
4.2 NMEA 2000 PGN Commands .....	13
<b>SPECIFICATION</b> .....	<b>SP-1</b>
<b>PACKING LISTS</b> .....	<b>A-1</b>
<b>OUTLINE DRAWINGS</b> .....	<b>D-1</b>
<b>INTERCONNECTION DIAGRAM</b> .....	<b>S-1</b>

# FOREWORD

---

## A Word to the Owner of the GP-330B

Congratulations on your choice of the FURUNO GP-330B GPS Receiver. We are confident you will see why the FURUNO name has become synonymous with quality and reliability.

Since 1948, FURUNO Electric Company has enjoyed an enviable reputation for quality marine electronics equipment. This dedication to excellence is furthered by our extensive global network of agents and dealers.

This equipment is designed and constructed to meet the rigorous demands of the marine environment. However, no machine can perform its intended function unless installed, operated and maintained properly. Please carefully read and follow the recommended procedures for installation and maintenance.

Thank you for considering and purchasing FURUNO equipment.

## Feature

The GP-330B is a high performance GPS Receiver designed for any type of vessel. This compact and cost-effective receiver offers extremely accurate position fixes, within 3 meters with the WAAS mode activated.

- 65 channels for receiving 12 satellites simultaneously
- Output in CAN bus or NMEA 0183 format
- Position fixed within approx. 60 seconds after start up
- Position updated every second
- Space-saving installation
- Ideal position-fixing sensor for NavNet 3D series

## Program No.

- BOOT:1.\*\*\*
- Appl:1.\*\*\*
- GPS:13.\*.\*

\*\* denotes minor modifications.

## CE/UKCA declaration

With regards to CE/UKCA declarations, please refer to our website ([www.furuno.com](http://www.furuno.com)), for further information on RoHS conformity declarations.

## Disclosure of Information about China RoHS

With regards to China RoHS information for our products, please refer to our website ([www.furuno.com](http://www.furuno.com)).

# SYSTEM CONFIGURATION

## Type A

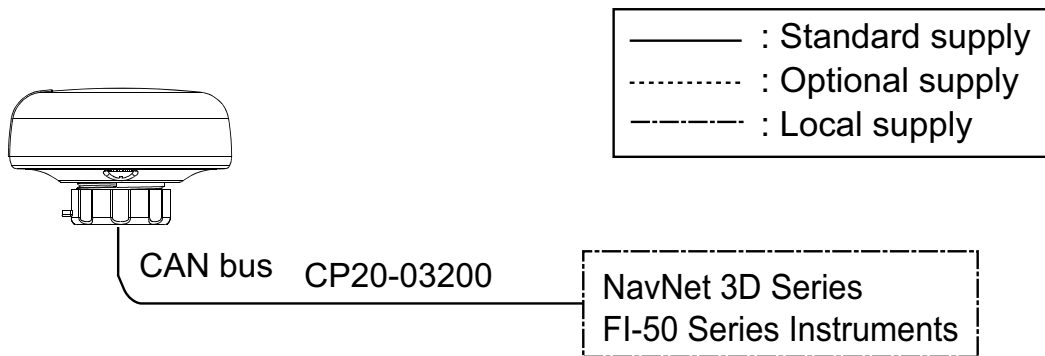

## Type B

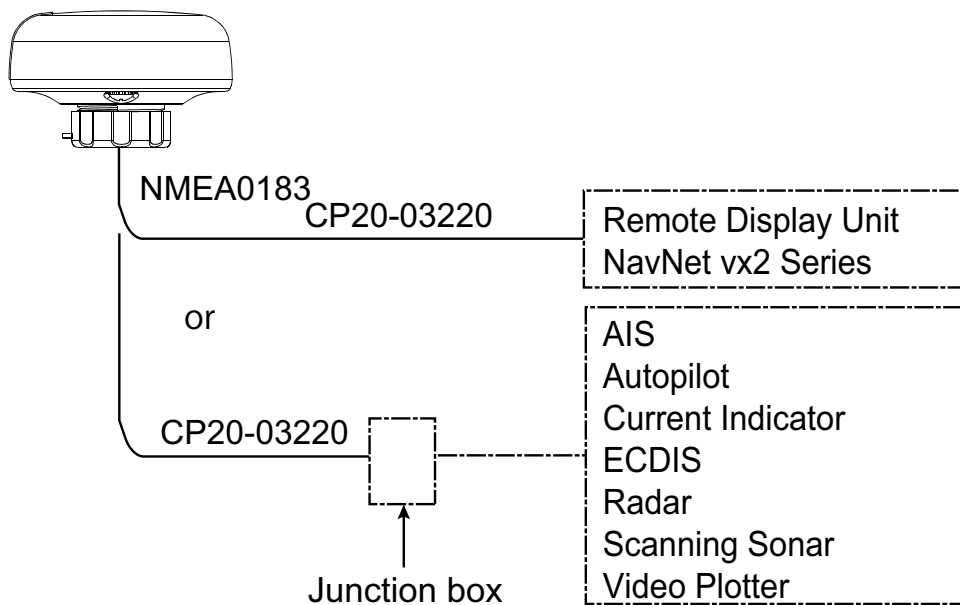

## Type N

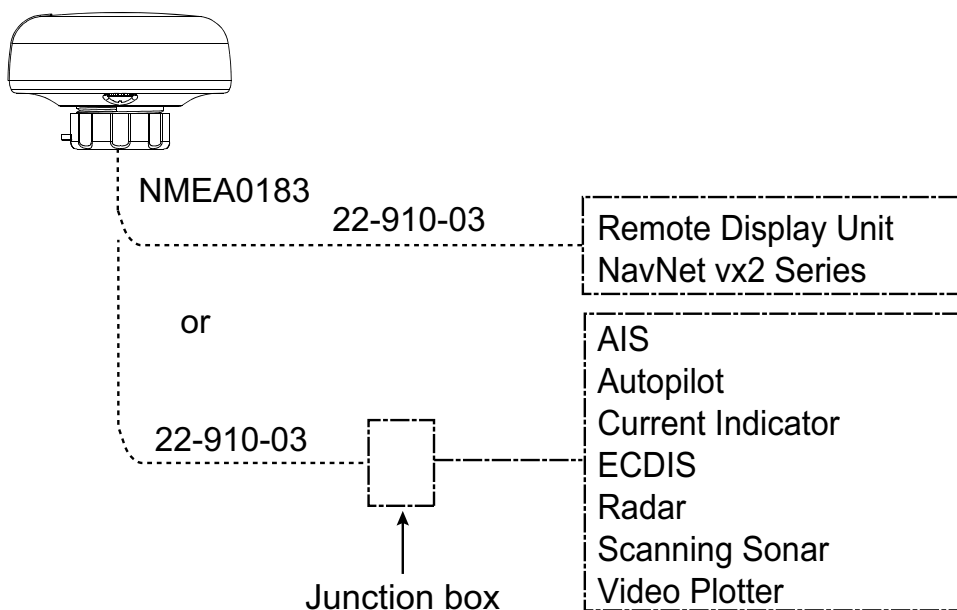

# 1. INSTALLATION

## 1.1 Equipment Lists

Name	Type	Code No.	Qty	Remarks
<b>Standard Supply</b>				
GPS Receiver	GP-330B		1	
Installation Materials	CP20-03200	000-012-581	1	With CAN bus cable (6 m) (A Type) and pipe mount kit, deck mount kit.
	CP20-03210	000-012-582		No cable (N Type) with pipe mount kit and deck mount kit.
	CP20-03220	000-037-142		With NMEA0183 cable (10 m) (B Type) and pipe mount kit, deck mount kit.
<b>Optional Supply</b>				
Cable Assy.	33-1209-01	001-193-460-10	1	6 m, for CAN bus
Cable Assy.	33-1209-02	001-193-470-10	1	10 m, for CAN bus
Cable Assy.	22-910-03	001-163-140-10	1	10 m, for NMEA 0183
Cable Assy.	MJ-A7SPF/ SRMD-100	000-144-534-11	1	10 m, straight, MJ7P(P)-MJ7P(J), for NMEA 0183
Flush Mount Kit	GP-330B- FLUSH KIT	001-037-630	1	
Pipe Mount Kit	GP-330B- PIPE KIT	001-041-560	1	

## 1.2 Tools & Materials

<ul style="list-style-type: none"> <li>• Mounting hardware with standard 1-14" UNS (Pole/Rail Mount installation) threads</li> <li>• Safety goggles</li> <li>• Dust mask</li> <li>• Screwdrivers (Pole/Rail Mount or Deck Mount installation)</li> <li>• Teflon pipe thread tape, 1/2" wide (some installations)</li> <li>• Pencil (some installations)</li> <li>• Electric drill (some installations)</li> <li>• Drill bits (some installations):             <ul style="list-style-type: none"> <li>• Pilot hole - 3 mm or 1/8"</li> <li>• Deck mount screw holes - 5.1 mm or #7</li> <li>• Deck mount cable hole - 25 mm or 1"</li> <li>• Flush mount stud holes - 6 mm or 1/4"</li> <li>• Flush mount cable hole - 38 mm or 1-1/2"</li> </ul> </li> <li>• Loctite 242 or removable thread locker (Flush Mount installation)</li> <li>• Cable ties (some installations)</li> </ul>
---



## 1.3 Choosing the Mounting Location

For a reliable GPS signal, selecting the best location for the receiver is very important. It can be mounted on a pole, rail, or flat surface. Choose a location that balances the requirements below.

- The GPS receiver must have a clear view of the sky to the horizon in all directions. *Note* that frozen water spray may degrade reception.
- Referring to the figure below for distances, mount away from any VHF radio, satellite communications equipment, radar, or other antennas to avoid mutual interference.
- Mount above or below any radar beam. *Do not* mount within a radar beam.
- Mount reasonably level with the earth's surface -- *not* tilted to one side.
- *Do not* mount on top of a sailboat mast. The sway will cause jitter in the data.
- *Do not* mount where the GPS receiver could be a tripping hazard or tread upon.
- Be sure there is access to the underside of the mounting surface.
- Be sure the cable(s) can be routed to reduce electrical interference from other electrical wiring and any equipment with a strong magnetic field such as radar, radio transmitters, engines, generators, etc. Separate the cables by at least 1 meter (3 feet).

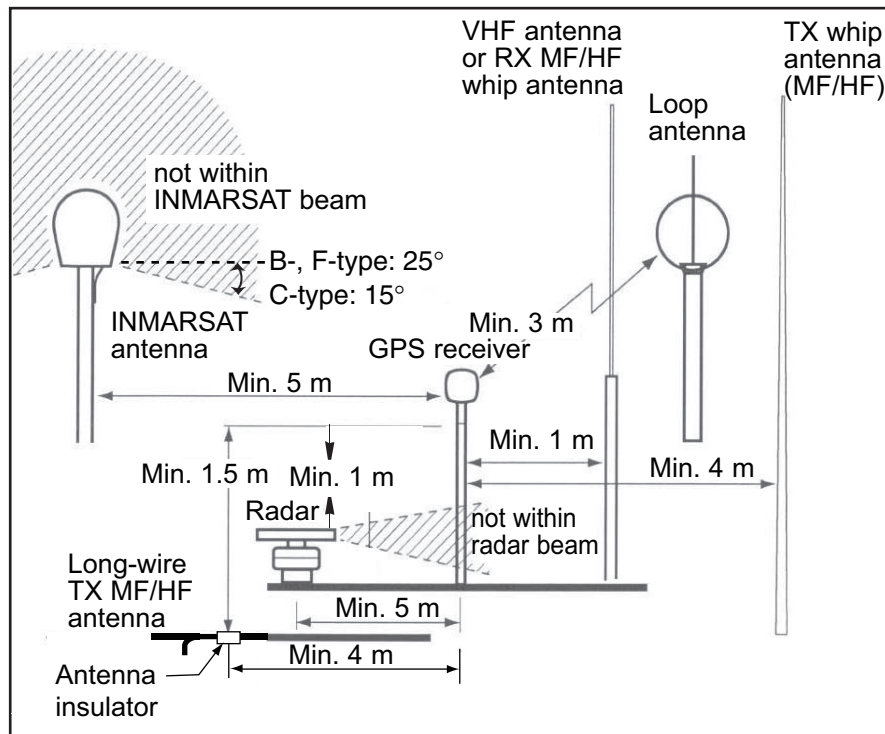

## 1.4 Mounting

### 1.4.1 Pole/Rail (Pipe) Mount

**CAUTION!** - Do not use the flush mount materials to mount the unit on a pole. Water may leak into the unit.

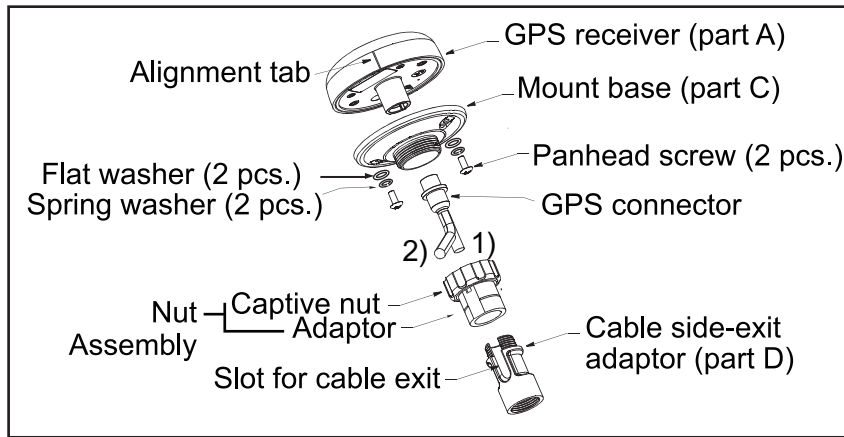

The nut assembly supplied has standard 1-14" UNS threads that can be screwed to a standard marine antenna mount, extension pole, or rail-mount bracket. Before beginning the installation, plan for securing the pole/rail bracket to the boat and purchase locally all the necessary hardware. It may be helpful to fasten the pole/rail bracket to the boat before proceeding.

1. Unscrew the mount base (part C) from the surface bracket (part E). (The surface bracket is not used in this installation. See the next page for part (E)).
2. Remove the label from the GPS receiver's socket (underside of receiver). The label may be discarded.  
Fasten the mount base (part C) to the GPS receiver (part A) with the supplied two panhead screws, flat washers and spring washers. The torque for the screws is 1.35 N•m.
3. Decide if you want the cable to exit through the center or along the side of the pole/rail bracket. Slide the nut assembly (captive nut and adaptor) onto the cable at the 9-pin *GPS* connector end. *Do not connect the GPS receiver at this time.*
  - 1) **Center exit:** Pass the *instrument* connector end of the cable down through the center of the pole. *Be sure to leave several inches of cable extending beyond the nut assembly.*
  - 2) **Side exit:** Place the cable side-exit adaptor (part D) over the cable. *Being sure the cable is passing through the slot in the side*, screw the nut assembly onto the adaptor. **Hand-tighten only.** *Do not* over tighten.  
**Note:** Use the adaptor supplied as it has smooth edges that will *not* chafe the cable. *Do not* use a purchased part.

**CAUTION:** if you use a thread locker, use teflon pipe thread tape. Do not use a liquid thread locker as it may weaken the plastic, causing it to swell and crack.
4. Screw the extension pole/rail bracket onto the nut assembly/cable side-exit adaptor. **Hand-tighten only.** *Do not* over tighten.
5. Remove the protective cap from the GPS connector on the cable. (Save the cap to protect the connector, when the receiver is removed.) Plug the cable firmly into the GPS receiver.
6. With the alignment tab on the GPS receiver facing forward, slide the captive nut upward and screw it onto the mount base. **Hand-tighten only.** *Do not* over tighten.

## 1.4.2 Deck Mount

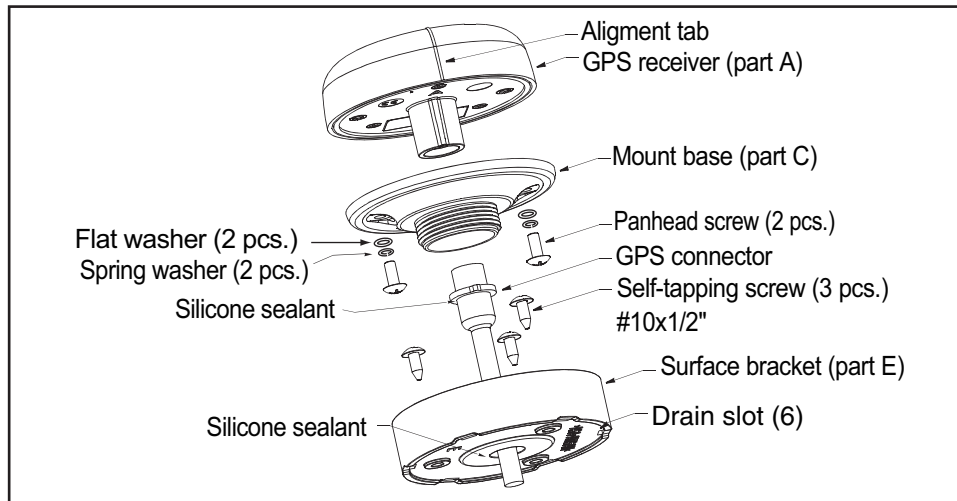

See the outline drawing for mounting hole dimensions and fixing instructions

1. Unscrew the mount base (part C) from the surface bracket (part E) (see figure above). Remove the label from over the GPS receiver's socket. (The label may be discarded.) Fasten the mount base (part C) to the GPS receiver (part A) with the supplied panhead screws, flat washers and spring washers. The torque for the screws is 1.35 N•m.
2. Screw the surface bracket (part E) onto the mount base of the assembled GPS receiver. Use a pencil to extend the alignment tab onto the surface bracket. Unscrew the surface bracket.
3. At the selected location, position the surface bracket with the pencil mark facing forward. Using it as a template, mark the position for the three mounting screws and the center hole for the cable.
4. Using a 3 mm or 1/8" bit, drill the pilot holes. Using 5.1 mm or #7 bit, drill the three mounting holes. Drill the cable hole with a 25 mm or 1" bit.  
**Fiberglass**-Minimize surface cracking by running the drill in reverse until the gelcoat is penetrated.
5. At the location shown in the figure above, coat the surface bracket (part E) with silicone sealant.
6. Apply silicone sealant to the three #10 x 1/2" self-tapping screws to seal the deck. With the pencil mark facing forward, fasten the surface bracket in place. *Do not block the drain slots.* They will allow any water that accumulates inside the surface bracket to escape. **CAUTION:** Do not use a liquid thread locker as it may weaken the plastic, causing it to swell and crack.
7. Wrap pipe thread tape around the threads of the mount base two times to seal it tightly to the surface bracket.
8. Coat the part of the GPS connector shown in the figure on page 4 with silicone sealant. Pass the GPS connector end of the cable up through the hole in the surface bracket.
9. Remove the protective cap from the cable's GPS connector. (Save the cap to protect the connector, when the receiver is removed.) Plug the cable firmly into the GPS receiver.
10. Counterclockwise twist the cable three and one-half turns. Then screw the GPS receiver onto the installed surface bracket. **Hand-tighten only. Do not over-tighten.**

## 1. INSTALLATION

### 1.4.3 Flush Mount (Optional kit GP-330B-FLUSH KIT (code no.: 001-037-630) required.)

See the outline drawing for mounting hole dimensions and fixing instructions.

1. Remove the label from over the GPS receiver's socket. (The label may be discarded.) Apply *removable* thread locker to the two studs. Screw the studs into the underside of the GPS receiver (part A).
2. Using the gasket (part B) as a template, position it at the selected mounting location *upside down* with the arrow facing forward. Mark the position for the two mounting holes and the center hole for the cable.

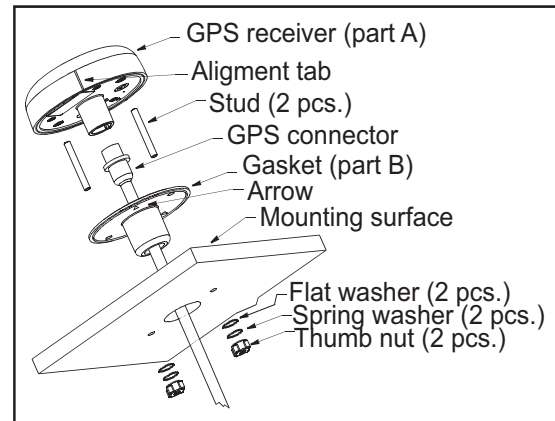

3. Using a 3 mm or 1/8" bit, drill the pilot holes. Using a 6 mm or 1/4" bit, drill the two mounting holes for the studs. Drill the cable hole with a 38 mm or 1-1/2" bit.  
**Fiberglass**-Minimize surface cracking by running the drill in reverse until the gelcoat is penetrated.
4. Pass the *instrument* connector-end of the cable through the center of the gasket and down through the center mounting hole in the boat.
5. Plug the cable firmly into the GPS receiver.
6. Orient the gasket with the arrow facing in the same direction as the alignment tab on the GPS receiver. Push the gasket onto the studs and slide it over the connector.  
**Note:** The gasket fits one way only. A groove in the gasket fits over the alignment tab on the connector.
7. With the GPS receiver alignment tab pointing forward, push the studs through the mounting surface. *Check to be sure the gasket is tucked under the lip of the unit.* From underneath the mounting surface, slide the flat washer and spring washer onto each stud. Fasten the studs with the thumb nuts. **Hand-tighten** only. *Do not* over tighten.
8. Coat the circumference of the GPS receiver with silicone sealant so that there is no space between the GPS receiver and the mounting surface.

## 2. WIRING, SETTINGS

---

### 2.1 CAN bus Connection (Type A or N)

The LEN (Load Equivalency Number) for this equipment is 2.

#### 2.1.1 Direct Connection

Insert the contact pin (supplied) into the #5 socket of the GPS Receiver connector to activate the termination resistor. (See page 8 for location of #5 socket.) Route the cable assembly to the CAN bus device. Coil any excess cable and secure it with a cable tie to prevent damage. Connect the cable assembly to the CAN bus device.

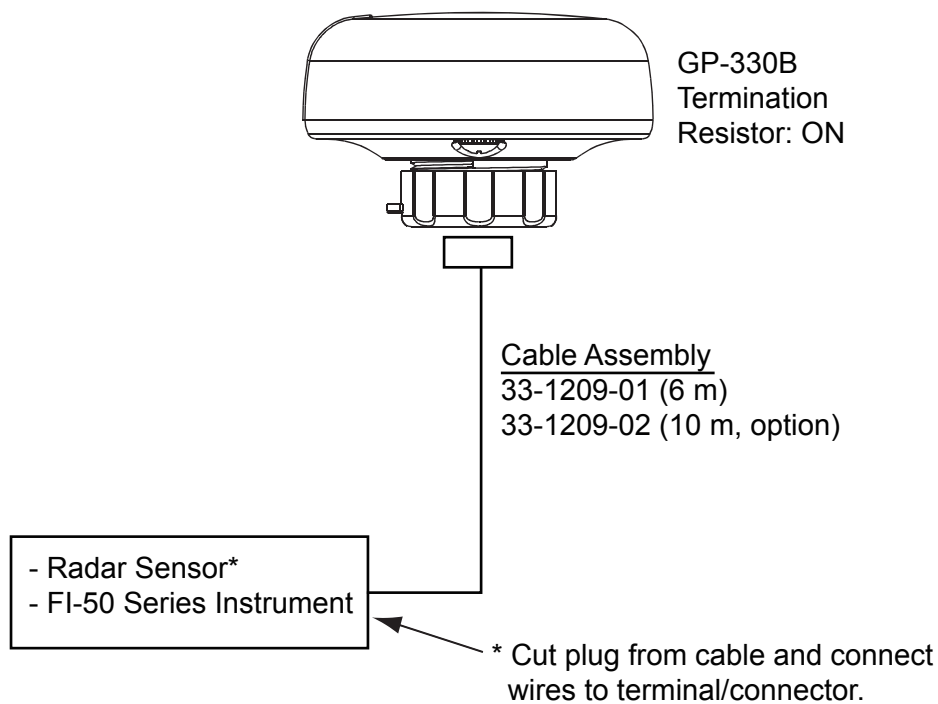

## 2.1.2 Network Connection

### Drop cable connection

A drop cable is connected to a backbone cable with T-type connectors\*. The backbone cable is of the "light" type. Attach a terminator at the ends of the backbone cable. *Only two termination resistors are required on an CAN bus network. More than two will degrade performance.*

\* Recommended type: LTWSS-050505-FMF-TS001 (LTW Technology, Inc.), or equivalent

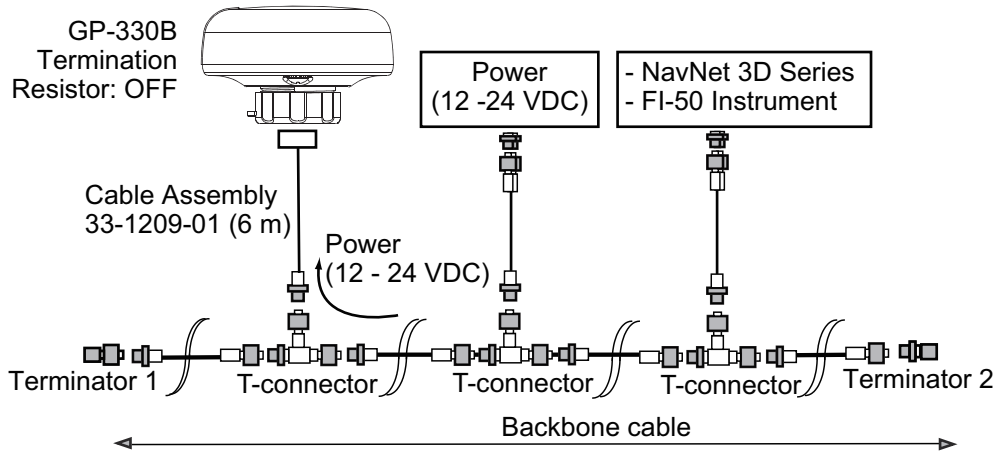

### Backbone cable connection

Use this connection method to connect the GP-330B at the final node in the backbone cable. Use T-type connectors to connect equipment to the backbone cable.

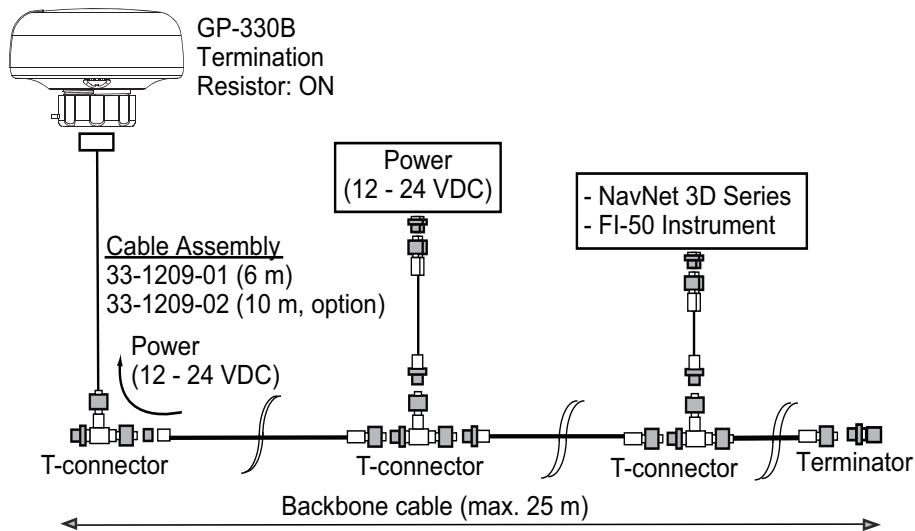

Connect the GPS Receiver at the last node in the network. Insert the contact pin (supplied) into the #5 socket of the GPS Receiver connector to activate the termination resistor.

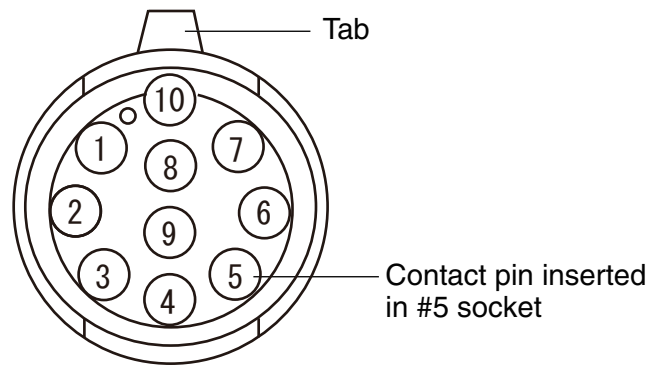

### 2.1.3 Routing and Connecting the Cable Assembly

Route the cable assembly to the CAN bus device. Coil any excess cable and secure it with a cable tie to prevent damage. Connect the cable assembly to the CAN bus device.

## 2.2 NMEA 0183 Connection (Type B or N)

### Wiring outline

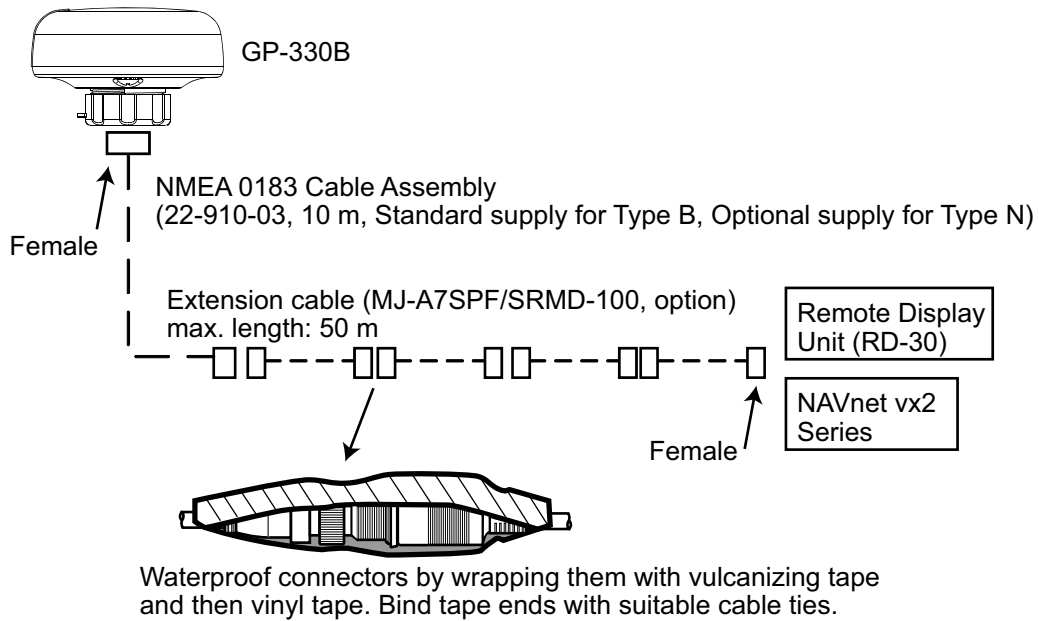

**Note:** When connecting to equipment other than a Remote Display Unit or NAVnet vx2 series unit, refer to the INTERCONNECTION DIAGRAM at the back of this manual.

### Wiring procedure

Route the cable assembly to the display. Coil any excess cable and secure it with a cable tie to prevent damage. Connect the GPS Receiver to your NMEA 0183 display.



## 2.3 Settings for NavNet vx2

The following items in the NavNet vx2 menu system are applicable to the GP-330B. For details and operating procedure, see the Installation Manual for your NavNet vx2 model.

### **NAV SETUP menu**

Set POSITION SOURCE to GPS or ALL.

### **GPS SETUP menu**

- GEODETIC DATUM  
Select your chart type. WGS-84 is the GPS standard.
- FIX MODE  
Set position fixing mode to 2D/3D (three or four satellites in view).
- COLD START  
Clear the Almanac currently stored in the GPS receiver to receive the latest Almanac.

### **WAAS SETUP menu**





- WAAS MODE  
Select ON to use the WAAS mode.
- WAAS SEARCH  
Set WAAS satellite search method to automatic.
- CORRECTIONS DATA  
Select the type of message for WAAS connection, 00 for North America, 02 elsewhere.

WAAS settings effective from the version numbers shown below.

<b>C-MAP specification</b>		<b>NAVIO specification</b>	
Program No.	Model	Program No.	Model
1950026-03.02	Model 1804C-BB	1950025-03.02	Model 1804C-BB
1950024-03.02	Model 1804C	1950023-03.02	Model 1804C
1950028-03.02	Model 1704C	1950027-03.02	Model 1704C

# 3. MAINTENANCE, TROUBLESHOOTING

---

 <b>CAUTION</b>	<b>NOTICE</b>
 <b>Do not disassemble the unit.</b> Disassembling the unit will damage the waterproof seal. Further, there are no user-serviceable parts inside.	 <b>Do not apply paint, anti-corrosive sealant or contact spray to coating or plastic parts of the equipment.</b>  Those items contain organic solvents that can damage coating and plastic parts, especially plastic connectors.
 <b>Do not immerse in water or pressure wash.</b>  Doing so may allow water to infiltrate the sensor, voiding the warranty.	

## 3.1 Maintenance

The GP-330B is virtually maintenance free. However, it is recommended to wipe it with a water-moistened cloth periodically to remove accumulated dirt and water deposits.

## 3.2 Troubleshooting

If position is not found within a reasonable amount of time, check the following items.

- Is there power to the GPS receiver? (Check unit that is supplying power to the GP-330B.)
- Are all the connections tight?
- Does the GPS receiver have a clear view of the sky?
- Is there interference from other antennas or instruments?
- Is cabling damaged?
- Is the cable-run free of kinks or damage?
- Is there damage to the GPS receiver?
- Is there ice on the GPS receiver?

# 4. TECHNICAL INFORMATION

---

## 4.1 NMEA 0183 Sentences

### Transmitted NMEA 0183 Sentences

\$GPDTM*	Datum Reference
\$GPGGA*	GPS Fix Data
\$GPGLL*	Geographic Position -Latitude / Longitude
\$GPGSA	GNSS DOP and Active Satellites
\$GPGSV	GNSS Satellites in View
\$GPRMC*	Recommended Minimum Specific GNSS Data
\$GPVTG*	Course Over Ground and Ground Speed
\$GPZDA*	Time and Date
\$PFEC,pidat	Response to \$PFEC,pireq

\* Default output

### Received NMEA 0183 Sentences and Commands

\$PAMTC,BAUD	Change the baud rate from the nominal 4800 baud to 38400 baud
\$PAMTC,EN	Enable/disable transmission of specific sentences, and change their rate of transmission
\$PAMTC,ERST	Reset the user portion of nonvolatile EEPROM to factory defaults
\$PAMTC,OPTION	WAAS ON/OFF. Set 3d/Auto mode.
\$PAMTC,POST	Set Query Power On Self Test function
\$PAMTC,QPS	Query part number and serial number versions
\$PAMTC,QV	Query GPS hardware and firmware versions
\$PAMTC,RESET	Reset the GP-330B
\$PAMTC,SIM	Enable/disable Simulate Mode
\$PAMTX	Pause or resume all automatic transmission of messages
\$PFEC,pireq	Request to \$PFEC,pidat

## 4.2 NMEA 2000 PGN Commands

### Transmitted NMEA 2000 PGNs

PGN 059392	ISO Acknowledgment
PGN 060928	ISO Address Claim
PGN 065285	Proprietary: Boot State Acknowledgment
PGN 065287	Proprietary: Access Level
PGN 126208	Acknowledge Group Function
PGN 126464	PGN List - Transmit/Received PGN's Group
PGN 126720	Addressable Multi-Frame Proprietary
PGN 126992	System Time
PGN 126996	Product Information
PGN 126998	Configuration Information
PGN 127258	Magnetic Variation
PGN 129025	Position, Rapid Update
PGN 129026	COG & SOG, Rapid Update
PGN 129029	GNSS Position Data
PGN 129033	Time & Date
PGN 129044	Datum
PGN 129538	GNSS Control Status
PGN 129539	GNSS DOPs
PGN 129540	GNSS Sats in View

### Received NMEA 2000 PGNs

PGN 059904	ISO Request
PGN 060928	ISO Address Claim
PGN 126208	Request Group Function
PGN 126208	Command Group Function
PGN 126720	Addressable Multi-Frame Proprietary

**SPECIFICATIONS OF GPS RECEIVER  
GP-330B****1 GENERAL**

- |     |                          |   |
|-----|--------------------------|---|
| 1.1 | Receiving frequency      | 1575.42 MHz   |
| 1.2 | Tracking code            | C/A code, WAAS  |
| 1.3 | Number of channels       | GPS: 65 channels parallel, 12 satellites; WAAS: 1 channel |
| 1.4 | Accuracy                 | GPS: 10m approx. (2drms)<br>WAAS: 3m approx. (2drms)      |
| 1.5 | Position fixing time     | 60 s typical (cold start)                                 |
| 1.6 | Tracking velocity        | 999 kn  |
| 1.7 | Position update interval | 1 s (standard), 0.1 s (minimum)                           |

**2 INTERFACE**

- |     |                           |  |
|-----|---------------------------|--|
| 2.1 | Type of data              | CAN bus or NMEA0183 Ver.3.1 (selected by cable)  |
| 2.2 | Data sentences (NMEA0183) |  |
|     | Output                    | DTM, GGA, GLL, GSA, GSV, RMC, VTG, ZDA   |
| 2.3 | CAN bus PGN (NMEA2000)    |  |
|     | Input                     | 059904, 060928, 126208/720   |
|     | Output                    | 059392, 060928, 065281/285/287, 126208/464/720/992/996/998<br>127258, 129025/026/029/033/044/538/539/540, 130822/823/944 |

**3 POWER SUPPLY**

12-24 VDC (10.8-31.2 V): 90-45 mA max.

**4 ENVIRONMENTAL CONDITION**

- |     |                      |                      |
|-----|----------------------|----------------------|
| 4.1 | Ambient temperature  | -25°C to +55°C       |
| 4.2 | Relative humidity    | 95% or less at +40°C |
| 4.3 | Degree of protection | IP56                 |
| 4.4 | Bearing vibration    | IEC 60945 Ed.4       |

**5 UNIT COLOR**

N9.5

# PACKING LIST GP-330B-A

208D-X-9851-12

1/1

NAME	UNIT	OUTLINE	DESCRIPTION/CODE No.	Q'TY
GPS受信機	GPS RECEIVER		GP-330B	1
			000-012-580-00	
パイプマウントキット	PIPE MOUNT KIT.			
アダプター	CABLE SIDE-EXIT ADAPTOR		04-673-05	1
			000-168-927-11	
アダプター	ADAPTOR		04-564-07	1
			000-168-926-11	
ナット	CAPTIVE NUT		04-565-08	1
			000-168-925-11	
ハウジング	MOUNT BASE		04-670-04	1
			000-168-928-11	
ナット	PANHEAD SCREW		03-317-01	2
			000-160-544-10	
ナット	SPRING WASHER		03-314-01	2
			000-160-545-10	

(\*)1.(\*)2は、それぞれ組立てられています。

(\*)1.(\*)2 PRE-ASSEMBLED.

NAME	OUTLINE	DESCRIPTION/CODE No.	Q'TY
平座金		03-312-01	2
FLAT WASHER		000-160-546-10	
デッキマウント	DECK MOUNT KIT.		
プラスティックネジ		#10X1/2	3
SELF-TAPPING SCREW		000-168-931-10	
ブラケット		04-691-03	1
SURFACE BRACKET		000-168-930-11	
工事材料	INSTALLATION MATERIALS		
ケーブル(カミヒン)		33-1209-01 *6M*	1
NMEA2000 CABLE ASSEMBLY		001-193-460-10	
コンタクトピン		05-251-01	2
CONTACT PIN		000-168-935-10	
図書	DOCUMENT		
取扱説明書J/E		0MC-44520-*	1
OPERATOR'S MANUAL (JP/EN)		000-168-896-1*	

A-1

(略図の寸法は、参考値です。DIMENSIONS IN DRAWING FOR REFERENCE ONLY.)

C4452-Z01-M

# PACKING LIST GP-330B-N

20BD-X-9852-8

1/1

NAME	UNIT	OUTLINE	DESCRIPTION/CODE No.	Q'TY
GPS受信機	GPS RECEIVER		GP-330B	1
			000-012-580-00	
パイプマウントキット	PIPE MOUNT KIT.			
アダプター	CABLE SIDE-EXIT ADAPTOR		04-673-05	1
			000-168-927-11	
アダプター	ADAPTOR		04-564-07	1
			000-168-926-11	
ナット	CAPTIVE NUT		04-565-08	1
			000-168-925-11	
ハウジング	MOUNT BASE		04-670-04	1
			000-168-928-11	
ナット	PANHEAD SCREW		03-317-01	2
			000-160-544-10	
ナット	SPRING WASHER		03-314-01	2
			000-160-545-10	

(\*)1.(\*)2)は、それぞれ組立てられています。

(\*)1.(\*)2) PRE-ASSEMBLED.

NAME	OUTLINE	DESCRIPTION/CODE No.	Q'TY
平座金		03-312-01	2
FLAT WASHER		000-160-546-10	
デッキマウント	DECK MOUNT KIT.		
プラスティックネジ		#10X1/2	3
SELF-TAPPING SCREW		000-168-931-10	
ブラケット		04-691-03	1
SURFACE BRACKET		000-168-930-11	
工事材料	INSTALLATION MATERIALS		
コンタクトピン		05-251-01	2
CONTACT PIN		000-168-935-10	
図書	DOCUMENT		
取扱説明書J/E		OMC-44520-*	1
OPERATOR'S MANUAL (JP/EN)		000-168-896-1*	

# PACKING LIST GP-330B-B

20BD-X-9853-1

1/1

NAME	UNIT	OUTLINE	DESCRIPTION/CODE No.	Q'TY
GPS受信機	GPS RECEIVER		GP-330B	1
			000-012-580-00	
パイプマウントキット	PIPE MOUNT KIT.			
アダプター	CABLE SIDE-EXIT ADAPTOR		04-673-05	1
			000-168-927-11	
アダプター	ADAPTOR		04-564-07	1
			000-168-926-11	
ナット	CAPTIVE NUT		04-565-08	1
			000-168-925-11	
ハウジング	MOUNT BASE		04-670-04	1
			000-168-928-11	
六角コネジ	PANHEAD SCREW		03-317-01	2
			000-160-544-10	
六角座金	SPRING WASHER		03-314-01	2
			000-160-545-10	

(\*)1.(\*)2)は、それぞれ組立てられています。

(\*)1.(\*)2) PRE-ASSEMBLED.

NAME	OUTLINE	DESCRIPTION/CODE No.	Q'TY
平座金		03-312-01	2
FLAT WASHER		000-160-546-10	
デッキマウント	DECK MOUNT KIT.		
プラスティックネジ		#10X1/2	3
SELF-TAPPING SCREW		000-168-931-10	
ブラケット		04-691-03	1
SURFACE BRACKET		000-168-930-11	
工事材料	INSTALLATION MATERIALS		
ケーブル(カミヒン)		22-910-03	1
NMEA0183 CABLE ASSEMBLY		001-196-980-10	

## 図書

NAME	DESCRIPTION/CODE No.	Q'TY
取扱説明書J/E	0MC-44520-*	1
OPERATOR'S MANUAL (JP/EN)		



表1 TABLE 1

寸法区分 (mm) DIMENSION	公差 (mm) TOLERANCE
$L \leq 50$	$\pm 1.5$
$50 < L \leq 100$	$\pm 2.5$

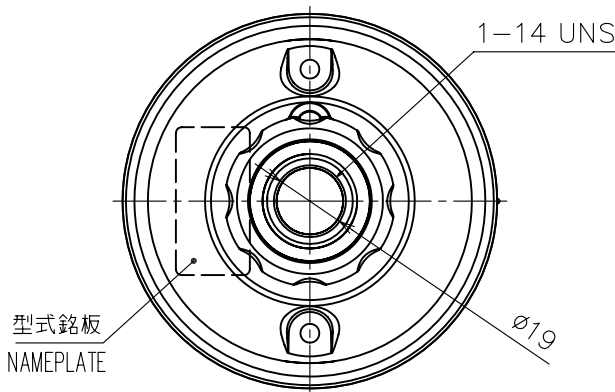
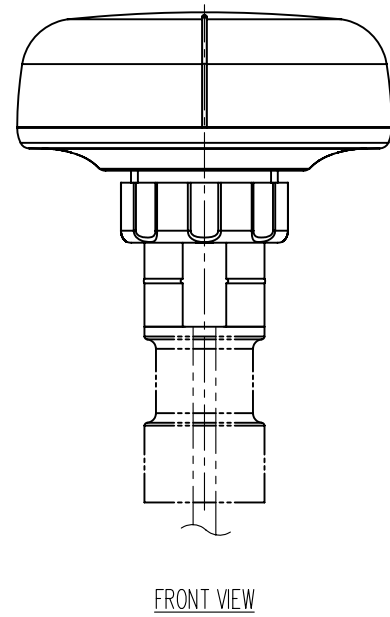
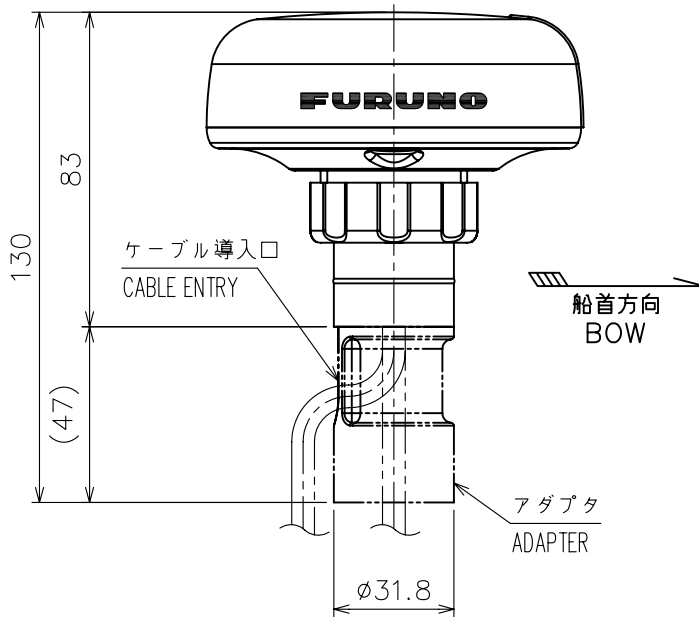
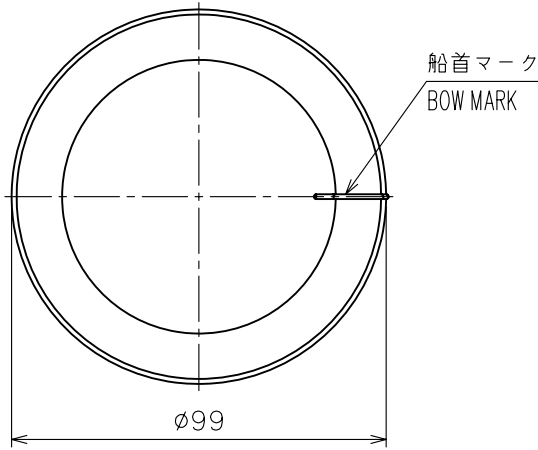

注 記

1) 指定外の寸法公差は表1による。

NOTE

1. TABLE 1 INDICATES TOLERANCE OF DIMENSIONS WHICH IS NOT SPECIFIED.

DRAWN	10/Mar/08 I. YAMASAKI	TITLE	GP-330B
CHECKED	10/Mar/08 T. TAKENO	名称	GPS受信機 (パイプ装備)
APPROVED	18/Mar/08 R. Esumi		外寸図
SCALE	1/2 MASS 0.18 $\pm 10\%$ kg	NAME	GPS RECEIVER (PIPE MOUNT)
DWG.No.	C4452-G01-A	REF.No.	20-034-100G-0
		OUTLINE DRAWING	

表 1 TABLE 1

寸法区分 (mm) DIMENSION	公差 (mm) TOLERANCE
$L \leq 50$	$\pm 1.5$
$50 < L \leq 100$	$\pm 2.5$

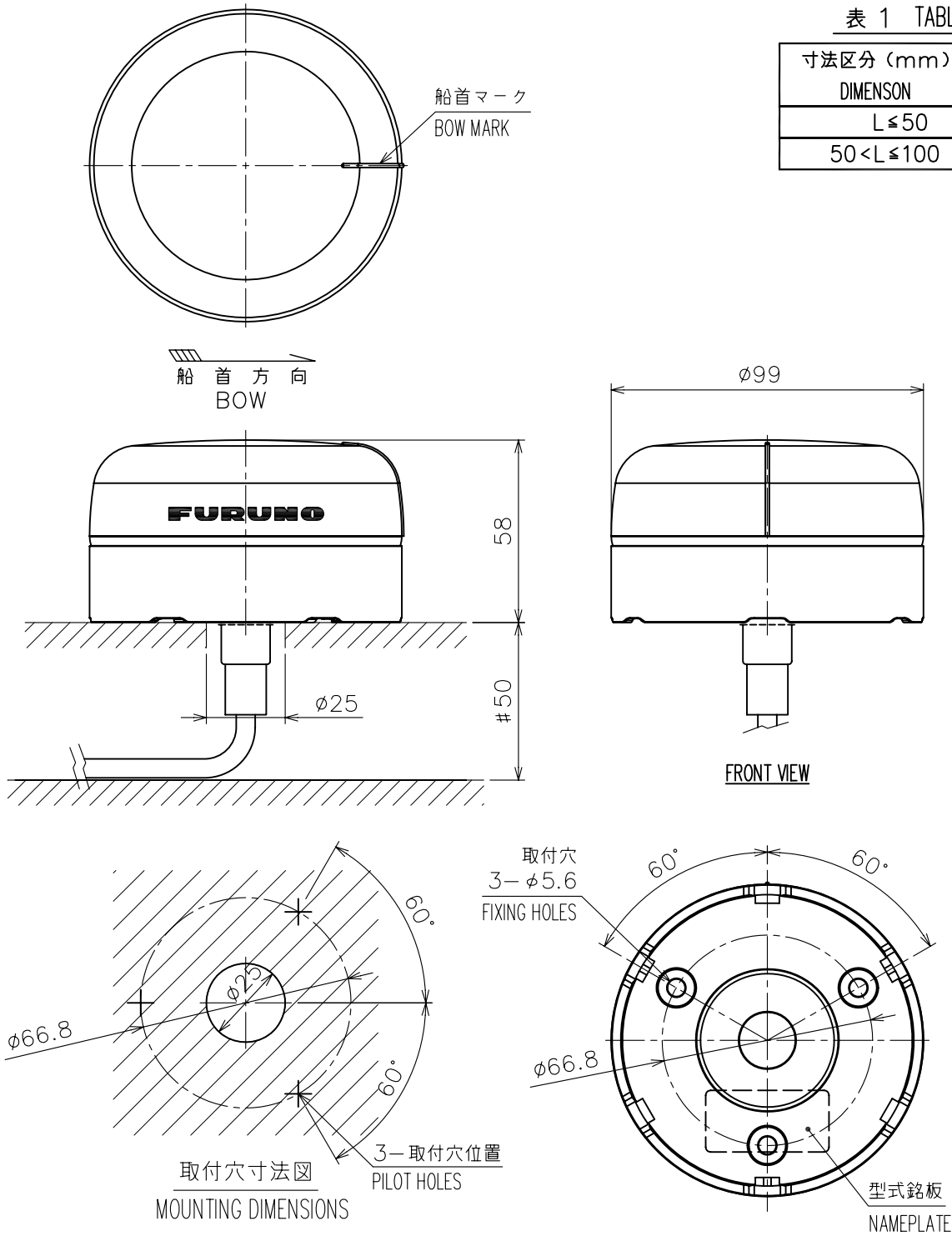

- 注 記
- 1) 指定外の寸法公差は表 1 による。
  - 2) #印寸法は最小サービス空間寸法とする。
  - 3) 取付用ネジはタッピンネジ呼び径5を使用のこと。

- NOTE
1. TABLE 1 INDICATES TOLERANCE OF DIMENSIONS WHICH IS NOT SPECIFIED.
  2. #: MINIMUM SERVICE CLEARANCE.
  3. USE TAPPING SCREWS  $\phi 5$  FOR FIXING THE UNIT.

DRAWN	10/Mar/08 I. YAMASAKI	TITLE	GP-330B
CHECKED	10/Mar/08 T. TAKENO	名称	GPS受信機 (デッキ装備)
APPROVED	18/Mar/08 R. Esumi		外寸図
SCALE	1/2 MASS 0.22 $\pm 10\%$ kg	NAME	GPS RECEIVER (DECK MOUNT)
DWG.No.	C4452-G02-A	REF.No.	20-034-110G-0
		OUTLINE DRAWING	

表 1 TABLE 1

寸法区分 (mm) DIMENSION	公差 (mm) TOLERANCE
$L \leq 50$	$\pm 1.5$
$50 < L \leq 100$	$\pm 2.5$

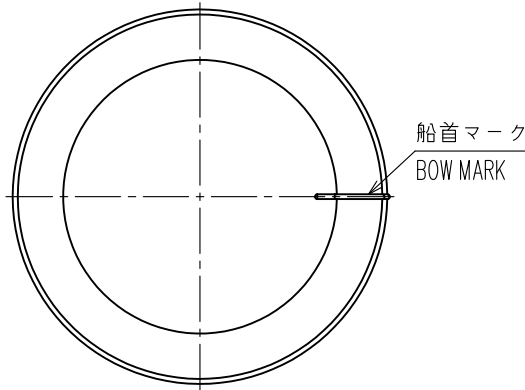

船首方向  
BOW

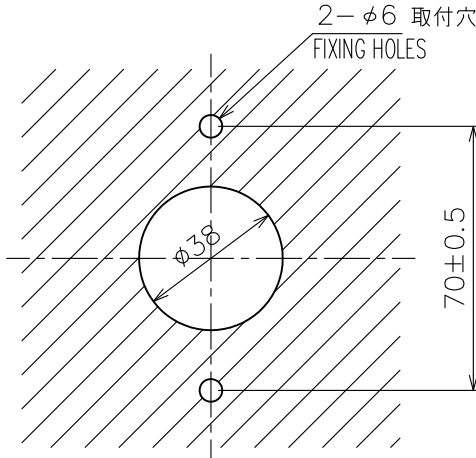
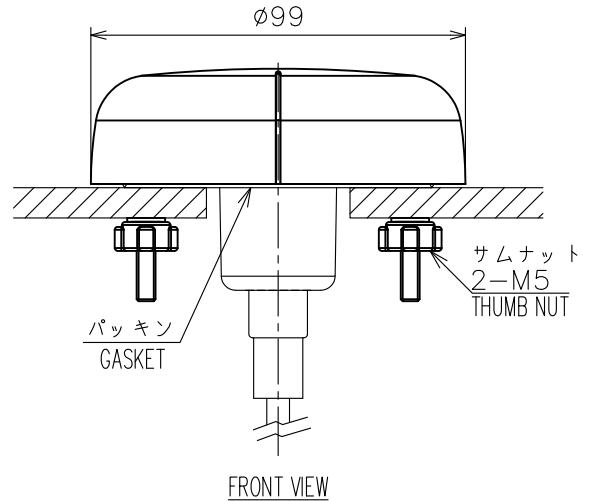
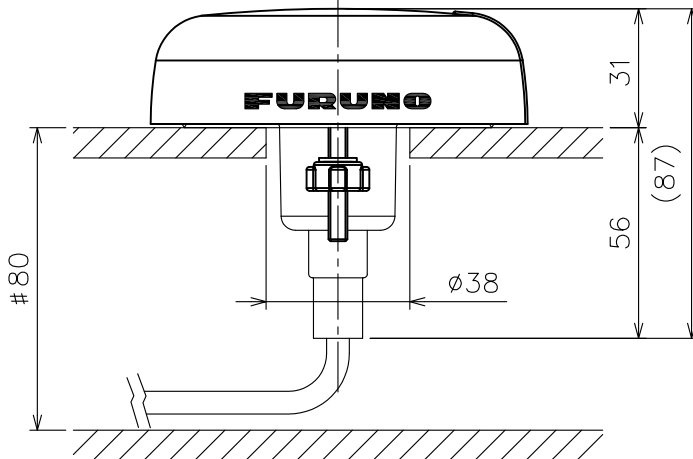

取付穴寸法図  
MOUNTING DIMENSIONS

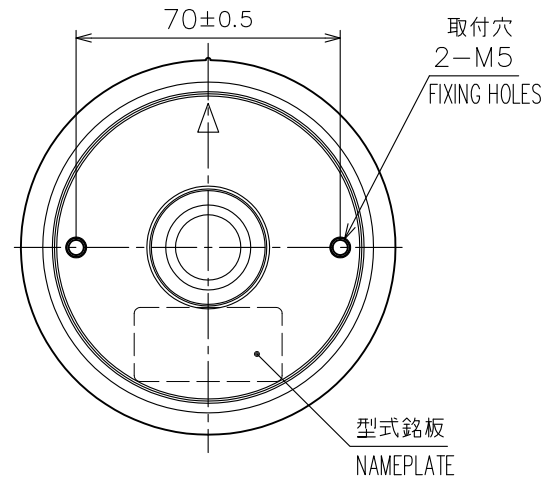

- 注 記
- 1) 指定外の寸法公差は表 1 による。
  - 2) # 印寸法は最小サービス空間寸法とする。
  - 3) 取付には M5 × 40 寸切りボルトを使用のこと。

- NOTE
1. TABLE 1 INDICATES TOLERANCE OF DIMENSIONS WHICH IS NOT SPECIFIED.
  2. #: MINIMUM SERVICE CLEARANCE.
  3. USE M5×40 STUD BOLTS FOR FIXING THE UNIT.

DRAWN	9/May/2023 S.HAN	TITLE	GP-330B
CHECKED	9/May/2023 T.YAMASAKI	名称	GPS受信機 (埋込装備)
APPROVED	11/May/2023 H.MAKI		外寸図
SCALE	1/2 MASS 0.16 ±10% kg	NAME	GPS RECEIVER (FLUSH MOUNT)
DWG.No.	C4452-G03-B	REF.No.	20-034-120G-0
		OUTLINE DRAWING	

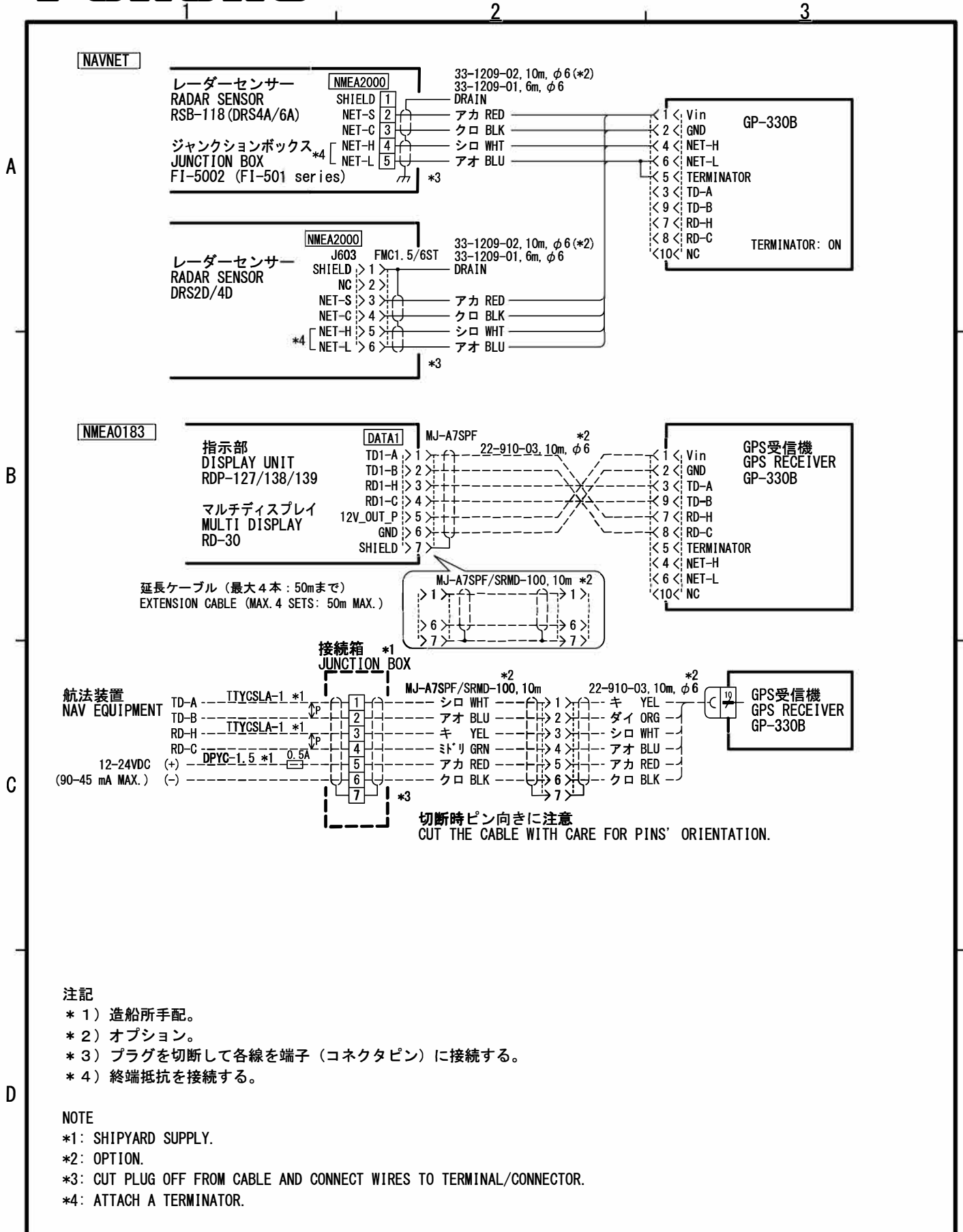

注記

- \* 1) 造船所手配。
- \* 2) オプション。
- \* 3) プラグを切断して各線を端子 (コネクタピン) に接続する。
- \* 4) 終端抵抗を接続する。

NOTE

- \*1: SHIPYARD SUPPLY.
- \*2: OPTION.
- \*3: CUT PLUG OFF FROM CABLE AND CONNECT WIRES TO TERMINAL/CONNECTOR.
- \*4: ATTACH A TERMINATOR.

DRAWN	11/Oct/2019 T. YAMASAKI	TITLE	GP-330B
CHECKED	11/Oct/2019 H. MAKI	名称	GPS受信機
APPROVED	15/Oct/2019 H. MAKI		相互結線図
SCALE	MASS kg	NAME	GPS RECEIVER
DWG. No.	C4452-C01-J	REF. No.	INTERCONNECTION DIAGRAM

# FURUNO Worldwide Warranty for Pleasure Boats (Except North America)

This warranty is valid for products manufactured by Furuno Electric Co. (hereafter FURUNO) and installed on a pleasure boat. Any web based purchases that are imported into other countries by anyone other than a FURUNO certified dealer may not comply with local standards. FURUNO strongly recommends against importing these products from international websites as the imported product may not work correctly and may interfere with other electronic devices. The imported product may also be in breach of the local laws and mandated technical requirements. Products imported into other countries as described previously shall not be eligible for local warranty service.

For products purchased outside of your country please contact the national distributor of Furuno products in the country where purchased.

This warranty is in addition to the customer's statutory legal rights.

## 1. Terms and Conditions of Warranty

FURUNO guarantees that each new FURUNO product is the result of quality materials and workmanship. The warranty is valid for a period of 2 years (24 months) from the date of the invoice, or the date of commissioning of the product by the installing certified dealer.

## 2. FURUNO Standard Warranty

The FURUNO standard warranty covers spare parts and labour costs associated with a warranty claim, provided that the product is returned to a FURUNO national distributor by prepaid carrier.

The FURUNO standard warranty includes:

- Repair at a FURUNO national distributor
- All spare parts for the repair
- Cost for economical shipment to customer

## 3. FURUNO Onboard Warranty

If the product was installed/commissioned and registered by a certified FURUNO dealer, the customer has the right to the onboard warranty.

The FURUNO onboard warranty includes

- Free shipping of the necessary parts
- Labour: Normal working hours only
- Travel time: Up to a maximum of two (2) hours
- Travel distance: Up to a maximum of one hundred and sixty (160) KM by car for the complete journey

## 4. Warranty Registration

For the Standard Warranty - presentation of product with serial number (8 digits serial number, 1234-5678) is sufficient. Otherwise, the invoice with serial number, name and stamp of the dealer and date of purchase is shown.

For the Onboard Warranty your FURUNO certified dealer will take care of all registrations.

## 5. Warranty Claims

For the Standard Warranty - simply send the defective product together with the invoice to a FURUNO national distributor. For the Onboard Warranty – contact a FURUNO national distributor or a certified dealer. Give the product's serial number and describe the problem as accurately as possible.

Warranty repairs carried out by companies/persons other than a FURUNO national distributor or a certified dealer is not covered by this warranty.

## 6. Warranty Limitations

When a claim is made, FURUNO has a right to choose whether to repair the product or replace it.

The FURUNO warranty is only valid if the product was correctly installed and used. Therefore, it is necessary for the customer to comply with the instructions in the handbook. Problems which result from not complying with the instruction manual are not covered by the warranty.

FURUNO is not liable for any damage caused to the vessel by using a FURUNO product.

The following are excluded from this warranty:

- a. Second-hand product
- b. Underwater unit such as transducer and hull unit
- c. Routine maintenance, alignment and calibration services.
- d. Replacement of consumable parts such as fuses, lamps, recording papers, drive belts, cables, protective covers and batteries.
- e. Magnetron and MIC with more than 1000 transmitting hours or older than 12 months, whichever comes first.
- f. Costs associated with the replacement of a transducer (e.g. Crane, docking or diver etc.).
- g. Sea trial, test and evaluation or other demonstrations.
- h. Products repaired or altered by anyone other than the FURUNO national distributor or an authorized dealer.
- i. Products on which the serial number is altered, defaced or removed.
- j. Problems resulting from an accident, negligence, misuse, improper installation, vandalism or water penetration.
- k. Damage resulting from a force majeure or other natural catastrophe or calamity.
- l. Damage from shipping or transit.
- m. Software updates, except when deemed necessary and warrantable by FURUNO.
- n. Overtime, extra labour outside of normal hours such as weekend/holiday, and travel costs above the 160 KM allowance
- o. Operator familiarization and orientation.

FURUNO Electric Company, March 1, 2011

## FURUNO Warranty for North America

FURUNO U.S.A., Limited Warranty provides a twenty-four (24) months LABOR and twenty-four (24) months PARTS warranty on products from the date of installation or purchase by the original owner. Products or components that are represented as being waterproof are guaranteed to be waterproof only for, and within the limits, of the warranty period stated above. The warranty start date may not exceed eighteen (18) months from the original date of purchase by dealer from Furuno USA and applies to new equipment installed and operated in accordance with Furuno USA's published instructions.

Magnetrons and Microwave devices will be warranted for a period of 12 months from date of original equipment installation.

Furuno U.S.A., Inc. warrants each new product to be of sound material and workmanship and through its authorized dealer will exchange any parts proven to be defective in material or workmanship under normal use at no charge for a period of 24 months from the date of installation or purchase.

Furuno U.S.A., Inc., through an authorized Furuno dealer will provide labor at no cost to replace defective parts, exclusive of routine maintenance or normal adjustments, for a period of 24 months from installation date provided the work is done by Furuno U.S.A., Inc. or an AUTHORIZED Furuno dealer during normal shop hours and within a radius of 50 miles of the shop location.

A suitable proof of purchase showing date of purchase, or installation certification must be available to Furuno U.S.A., Inc., or its authorized dealer at the time of request for warranty service.

This warranty is valid for installation of products manufactured by Furuno Electric Co. (hereafter FURUNO). Any purchases from brick and mortar or web-based resellers that are imported into other countries by anyone other than a FURUNO certified dealer, agent or subsidiary may not comply with local standards. FURUNO strongly recommends against importing these products from international websites or other resellers, as the imported product may not work correctly and may interfere with other electronic devices. The imported product may also be in breach of the local laws and mandated technical requirements. Products imported into other countries, as described previously, shall not be eligible for local warranty service.

For products purchased outside of your country please contact the national distributor of Furuno products in the country where purchased.

### WARRANTY REGISTRATION AND INFORMATION

To register your product for warranty, as well as see the complete warranty guidelines and limitations, please visit [www.furunousa.com](http://www.furunousa.com) and click on "Support". In order to expedite repairs, warranty service on Furuno equipment is provided through its authorized dealer network. If this is not possible or practical, please contact Furuno U.S.A., Inc. to arrange warranty service.

FURUNO U.S.A., INC.  
**Attention: Service Coordinator**  
4400 N.W. Pacific Rim Boulevard  
Camas, WA 98607-9408  
Telephone: (360) 834-9300  
FAX: (360) 834-9400

Furuno U.S.A., Inc. is proud to supply you with the highest quality in Marine Electronics. We know you had several choices when making your selection of equipment, and from everyone at Furuno we thank you. Furuno takes great pride in customer service.

## Declaration of Conformity

**[GP-330B]**

- Bulgarian (BG)** С настоящото Furuno Electric Co., Ltd. декларира, че гореспоменат тип радиосъоръжение е в съответствие с Директива 2014/53/ЕС, СИ 2017/1206. Цялостният текст на ЕС/УК декларацията за съответствие може да се намери на следния интернет адрес:
- Spanish (ES)** Por la presente, Furuno Electric Co., Ltd. declara que el tipo de equipo radioeléctrico arriba mencionado es conforme con la Directiva 2014/53/UE, SI 2017/1206. El texto completo de la declaración de conformidad de la EU/UK está disponible en la siguiente dirección Internet:
- Czech (CS)** Tímto Furuno Electric Co., Ltd. prohlašuje, že výše zmíněné typ rádiového zařízení je v souladu se směrnicí 2014/53/EU, SI 2017/1206. Úplné znění EU/SK prohlášení o shodě je k dispozici na této internetové adrese:
- Danish (DA)** Hermed erklærer Furuno Electric Co., Ltd., at ovennævnte radioudstyr er i overensstemmelse med direktiv 2014/53/EU, SI 2017/1206. EU/UK-overensstemmelseserklæringens fulde tekst kan findes på følgende internetadresse:
- German (DE)** Hiermit erklärt die Furuno Electric Co., Ltd., dass der oben genannte Funkanlagentyp der Richtlinie 2014/53/EU, SI 2017/1206 entspricht. Der vollständige Text der EU/UK-Konformitätserklärung ist unter der folgenden Internetadresse verfügbar:
- Estonian (ET)** Käesolevaga deklareerib Furuno Electric Co., Ltd., et ülalmainitud raadioseadme tüüp vastab direktiivi 2014/53/EL, SI 2017/1206 nõuetele. EL/GB vastavusdeklaratsiooni täielik tekst on kättesaadav järgmisel internetiaadressil:
- Greek (EL)** Με την παρούσα η Furuno Electric Co., Ltd., δηλώνει ότι ο προαναφερθέντας ραδιοεξοπλισμός πληροί την οδηγία 2014/53/ΕΕ, SI 2017/1206. Το πλήρες κείμενο της δήλωσης συμμόρφωσης ΕΕ/UK διατίθεται στην ακόλουθη ιστοσελίδα στο διαδίκτυο:
- English (EN)** Hereby, Furuno Electric Co., Ltd. declares that the above-mentioned radio equipment type is in compliance with Directive 2014/53/EU, SI 2017/1206. The full text of the EU/UK declaration of conformity is available at the following internet address:
- French (FR)** Le soussigné, Furuno Electric Co., Ltd., déclare que l'équipement radioélectrique du type mentionné ci-dessus est conforme à la directive 2014/53/UE, SI 2017/1206. Le texte complet de la déclaration UE/RU de conformité est disponible à l'adresse internet suivante:
- Croatian (HR)** Furuno Electric Co., Ltd. ovime izjavljuje da je gore rečeno radijska oprema tipa u skladu s Direktivom 2014/53/EU, SI 2017/1206. Cjeloviti tekst EU/UK izjave o sukladnosti dostupan je na sljedećoj internetskoj adresi:
- Italian (IT)** Il fabbricante, Furuno Electric Co., Ltd., dichiara che il tipo di apparecchiatura radio menzionato sopra è conforme alla direttiva 2014/53/UE, SI 2017/1206. Il testo completo della dichiarazione di conformità UE/RU è disponibile al seguente indirizzo Internet:
- Latvian (LV)** Ar šo Furuno Electric Co., Ltd. deklarē, ka augstāk minēts radioiekārta atbilst Direktīvai 2014/53/ES, SI 2017/1206. Pilns ES/AK atbilstības deklarācijas teksts ir pieejams šādā interneta vietnē:

- Lithuanian (LT) Aš, Furuno Electric Co., Ltd., patvirtinu, kad pirmiau minėta radijo įrenginių tipas atitinka Direktyvą 2014/53/ES, SI 2017/1206.  
Visas ES/JK atitiktis deklaracijos tekstas prieinamas šiuo interneto adresu:
- Hungarian (HU) Furuno Electric Co., Ltd. igazolja, hogy fent említett típusú rádióberendezés megfelel a 2014/53/EU, SI 2017/1206 irányelvnek.  
Az EU/EK-megfelelőségi nyilatkozat teljes szövege elérhető a következő internetes címen:
- Maltese (MT) B'dan, Furuno Electric Co., Ltd., niddikjara li msemmija hawn fuq-tip ta' taghmir tar-radju huwa konformi mad-Direttiva 2014/53/UE, SI 2017/1206.  
It-test kollu tad-dikjarazzjoni ta' konformità tal-UE/RU huwa disponibbli f'dan l-indirizz tal-Internet li ġej:
- Dutch (NL) Hierbij verklaar ik, Furuno Electric Co., Ltd., dat het hierboven genoemde type radioapparaat conform is met Richtlijn 2014/53/EU, SI 2017/1206.  
De volledige tekst van de EU/VK-conformiteitsverklaring kan worden geraadpleegd op het volgende internetadres:
- Polish (PL) Furuno Electric Co., Ltd. niniejszym oświadcza, że wyżej wymieniony typ urządzenia radiowego jest zgodny z dyrektywą 2014/53/UE, SI 2017/1206.  
Pełny tekst deklaracji zgodności UE/UK jest dostępny pod następującym adresem internetowym:
- Portuguese (PT) O(a) abaixo assinado(a) Furuno Electric Co., Ltd. declara que o mencionado acima tipo de equipamento de rádio está em conformidade com a Diretiva 2014/53/UE, SI 2017/1206.  
O texto integral da declaração de conformidade da EU/UK está disponível no seguinte endereço de Internet:
- Romanian (RO) Prin prezenta, Furuno Electric Co., Ltd. declară că echipamentul radio menționat mai sus este în conformitate cu Directiva 2014/53/UE, SI 2017/1206.  
Textul integral al declarației de conformitate UE/RU este disponibil la următoarea adresă internet:
- Slovak (SK) Furuno Electric Co., Ltd. týmto vyhlasuje, že vyššie spomínané rádiové zariadenie typu je v súlade so smernicou 2014/53/EÚ, SI 2017/1206.  
Úplné EÚ/SK vyhlásenie o zhode je k dispozícii na tejto internetovej adrese:
- Slovenian (SL) Furuno Electric Co., Ltd. potrjuje, da je zgoraj omenjeno tip radijske opreme skladen z Direktivo 2014/53/EU, SI 2017/1206.  
Celotno besedilo izjave EU/ZK o skladnosti je na voljo na naslednjem spletnem naslovu:
- Finnish (FI) Furuno Electric Co., Ltd. vakuuttaa, että yllä mainittu radiolaitetyyppi on direktiivin 2014/53/EU, SI 2017/1206 mukainen.  
EU/UK-vaatimustenmukaisuusvakuutuksen täysimittainen teksti on saatavilla seuraavassa internetosoitteessa:
- Swedish (SV) Härmed försäkrar Furuno Electric Co., Ltd. att ovan nämnda typ av radioutrustning överensstämmer med direktiv 2014/53/EU, SI 2017/1206.  
Den fullständiga texten till EU/Storbritannien-försäkran om överensstämmelse finns på följande webbadress:

#### Online Resource

[http://www.furuno.com/en/support/red\\_doc](http://www.furuno.com/en/support/red_doc)



**FURUNO ELECTRIC CO., LTD.**



Printed in Japan

Pub. No. OMC-44520-H

( YOTA ) GP-330B

・ FURUNO Authorized Distributor/Dealer お問い合わせは

A : MAY 2008  
H : MAY 31, 2023



00016889618