

FURUNO

NAV*pilot*

300/711C



NAVpilot-300
with Gesture Controller



NAVpilot-711C



www.furuno.com

NAVpilot



GC-001



NAVpilot-300



NAVpilot-711C



NAVpilot remarkable self-learning, adaptive software is developed by collaborative works between FURUNO and FLSI.



KEY FEATURES:

- ▶ Self-Learning and adaptive software; each time the boat goes to sea, the software learns the sea conditions and calculates the best adjustment for smooth steering
- ▶ Fantum Feedback™ offers simplified installation while delivering enhanced steering control - no need for physical rudder feedback unit
- ▶ Volvo Penta IPS, Yamaha Helm Master™, Yanmar, and Seastar VCS compatible
- ▶ Easy installation and smart network-based system configuration
- ▶ Waterproof Processing Unit (IP55) and Control Unit (IP56, IP65/67 for GC-001)
- ▶ Optional revolutionary SAFEHELM2 and POWER ASSIST brings unrivaled steering control and comfort to the helm
- ▶ Selectable “Economy” and “Precision” Navigation Modes combine adaptive technology, providing fuel and power savings of 2.5% or more*
- ▶ “Precision” provides tighter course keeping, within 0.01 NM of the set course
- ▶ Perfect for inboard or outboard power boats and sail boats (NAVpilot-711C only)
- ▶ Autopilot control available from NavNet TZtouch3/TZtouch2/TZtouch/GP-1871F/1971F

* Based on Furuno testing and “Scenarios for a Clean Energy Future 2000” - U.S. Department of Energy (<https://www.nrel.gov/docs/fy01osti/29379.pdf>)



Remote Navigation In The Palm of Your Hands (NAVpilot-300 only)

The Gesture Controller is a revolutionary and unique way to steer your boat remotely. By using Bluetooth signals, it is possible to control the Autopilot from anywhere on the boat within 10 meters. Just push and hold the button, point to the desired heading, and release the button to let the Autopilot redirect the boat!

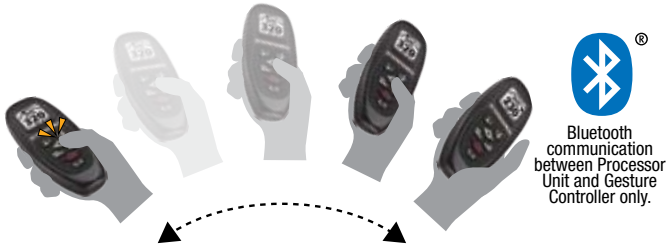

New SAFEHELM2 Reimagines Helm Control and Autopilot Safety



The optional SAFEHELM2 and POWER ASSIST features provide a unique interface to the vessel's hydraulic hand steering system, providing unrivaled comfort and control of steering directly from any manual helm on the vessel. These two modes greatly reduce steering effort and enhance the safety of your autopilot. The POWER ASSIST mode incorporates the SAFEHELM2 concept and provides speed-based, power assisted steering, which greatly reduces manual helm effort in maneuvering situations. POWER ASSIST is a unique helm-activated assisted steering feature that can augment or replace separate electric and power-robbing, engine-driven power steering systems on many vessels. POWER ASSIST reduces steering system complexity and costs while increasing fuel economy.

Compatible with EVC Engines

The NAVpilot-300/711C have the capability to work with Volvo Penta IPS, Yamaha Helm Master™, Yanmar 8LV engine systems and the Seastar Optimus360 Joystick system.



Yamaha Helm Master™ system*



Seastar Optimus360 Joystick system**



Volvo Penta IPS system* (Compatible with Volvo Penta IPS drive versions C, D, or E type.)



Yanmar Joystick Control System** (Compatible with Yanmar 8LV and JC10)

* Requires the optional IF700IPS to connect with NAVpilot-300/711C.
** Required the optional IFNMEA2K2 to connect with NAVpilot-300/711C.



Autopilot Control from NavNet TZtouch Series and GP-1871F/1971F

Furuno's NAVpilot Series are designed to match the GPS Chart Plotter GP-1871F/GP-1971F, the NavNet TZtouch Series, and other Furuno navigation equipment. The Plug and Play CAN bus interface allows for easy installation and exceptional interfacing.



SABIKI™ Mode for NAVpilot-300 and NAVpilot-711C



SABIKI™ mode lets the Autopilot take control while you are drifting astern so you can focus on fishing instead of steering. When moving astern at a slow pace, SABIKI™ mode is uniquely tailored for SABIKI fishing, jigging and bottom fishing. In order to maintain heading it is not sufficient to just reverse the engine and move astern. The steering has to be constantly adjusted in order to hold your heading. With SABIKI™ mode turned on, the direction can be kept just by adjusting the throttle. SABIKI fishing requires a bit of technique and whether you just started or have considerable experience, SABIKI™ mode will help you catch the bait fish needed for the big catch.

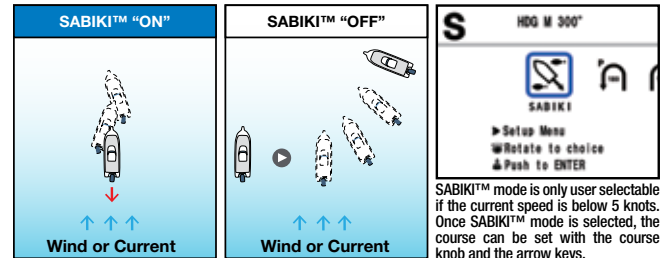

SABIKI™ mode is only user selectable if the current speed is below 5 knots. Once SABIKI™ mode is selected, the course can be set with the course knob and the arrow keys.

Display Options for Day and Night

Several types of graphic displays are available, allowing you to customize the data to suit your own preferences with either digital or analog graphics. The NAVpilot-300 and NAVpilot-711C feature a color day/night graphic display, giving you better sunlight viewability during the day, while not affecting your night vision when the sun goes down.

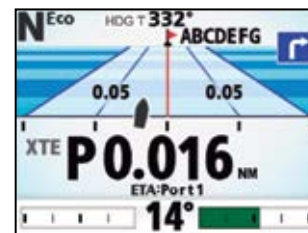

Highway Mode Day



Highway Mode Night



NAVpilot Offers Self-Learning and Adaptive Software

From the first dockside setup through the last voyage you made, NAVpilot continues to learn your vessel's steering characteristics. This allows dynamic adjustments to the boat's steering for vessel speed, trim, draft, tide and wind effects, weather, etc. These characteristics are stored in the processor's memory where they are continuously optimized to make the NAVpilot more versatile.

Auto

Maintains the desired heading, but the vessel may drift off course due to the effects of tide and wind.

Advanced Auto

Maintains the desired heading while compensating for the effects of tide and wind.

SABIKI™

Maintains the desired heading astern while compensating for the effects of tide and wind. Speed is limited to 5 knots.

Navigation

Steers the vessel towards the current waypoint while compensating for the effects of tide and wind.

Navigation

When connected to a GPS navigator, NAVpilot steers the vessel to follow a series of waypoints in succession. Upon arriving at each waypoint or destination, audible or visual alerts are activated.

Wind*

Maintains the desired heading toward true or apparent wind direction while compensating for the effects of tide and wind.
*Sailing craft only with proper wind data input

FishHunter™

Square **Zigzag** **Orbit** **Figure 8** **Spiral**

The NAVpilot will activate the FishHunter™ to perform various maneuvers around the target at a user-selected distance. The feature can also be used for Man Overboard (MOB).

NAVipilot-300

NAVipilot-711C

Control Unit FAP-3011

0.25 kg 0.53 lb

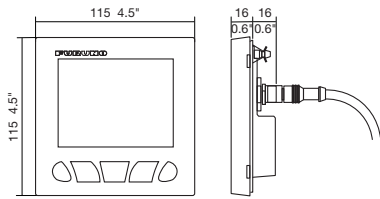

Gesture Controller GC-001

0.12 kg 0.26 lb

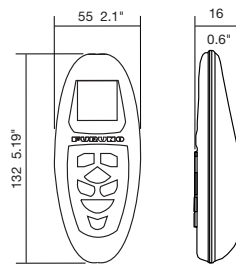

Processor Unit FAP-3012

1.5 kg 3.3 lb

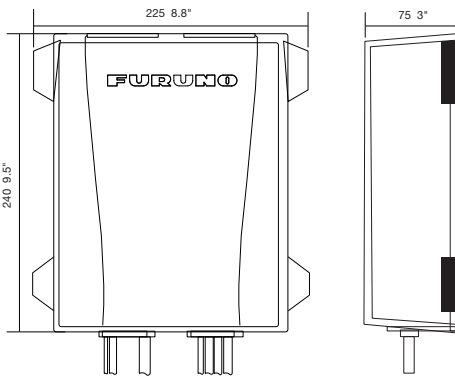

INTERCONNECTION DIAGRAM

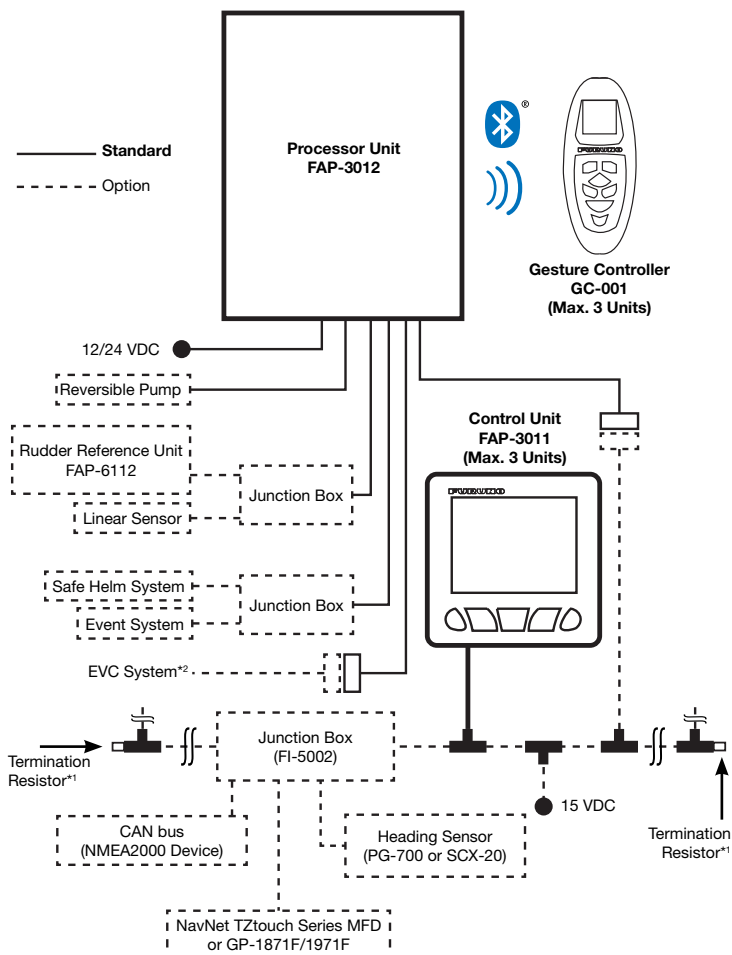

*1: Termination resistors must be installed at both ends of the backbone.
*2: VOLVO PENTA IPS, YAMAHA Helm Master, YANMAR VC10, SEASTAR SOLUTIONS OPTIMUS

Control Unit FAP-7011C

0.25 kg 0.53 lb

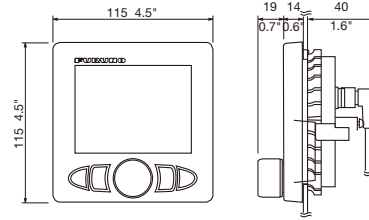

Cut-out for flush mount
(Wall thickness less than 10 mm)

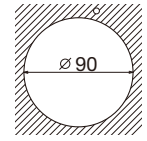

Cut-out for flush mount
(Wall thickness 10 to 20 mm)

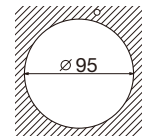

Processor Unit FAP-7002

0.25 kg 0.53 lb

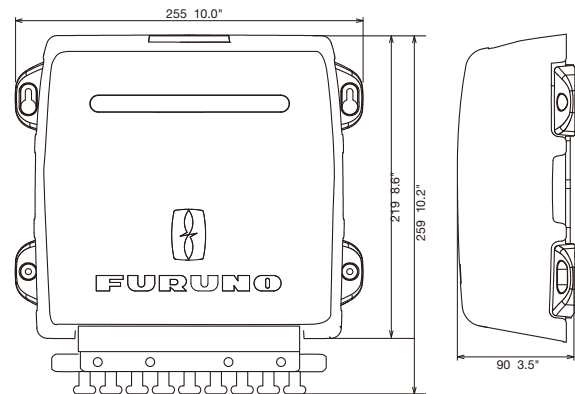

INTERCONNECTION DIAGRAM

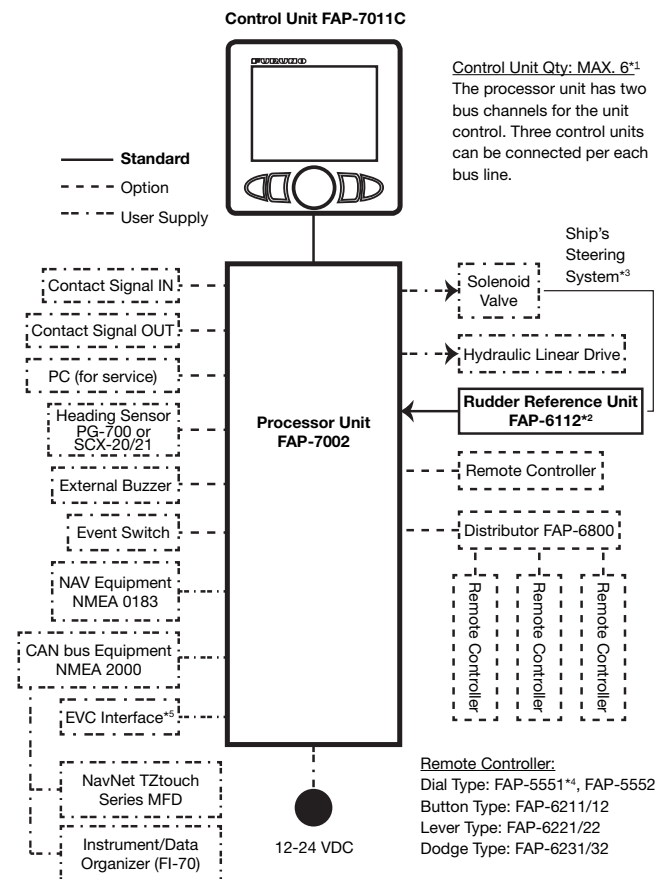

Control Unit Qty: MAX. 6*1
The processor unit has two bus channels for the unit control. Three control units can be connected per each bus line.

Remote Controller:
Dial Type: FAP-5551*4, FAP-5552
Button Type: FAP-6211/12
Lever Type: FAP-6221/22
Dodge Type: FAP-6231/32

*1: Attach the terminator (type: BD-07AFFM-LR7001) to the port not used on the last control unit in the series.
*2: Not required for Fantom Feedback™.
*3: Not required for a EVC system equipped vessel.
*4: Connect one Dial-type Remote Controller FAP-5551 to one Distributor FAP-6800.
*5: VOLVO PENTA IPS, YAMAHA Helm Master, YANMAR VC10, SEASTAR SOLUTIONS OPTIMUS

MODEL		NAVipilot-300	NAVipilot-711C
CONTROL UNIT			
Screen Size/Type		4.1" TFT color LCD	
Effective Display Area		82.56 (W) x 61.92 (H) mm	
Screen Resolution		320 x 240 dots (QVGA)	
Screen Brightness		700 cd/m ² typical	
Screen Contrast		8 steps	
PROCESSOR UNIT			
Steering Mode	STBY, Auto, Dodge, NFU (Non-follow up), Turn, SABIKI™, FishHunter™, Advanced Auto*, Navigation* *External data required	STBY, Auto, Dodge, Turn, Remote, SABIKI™, Advanced Auto*, Navigation*, Wind*, FishHunter™* *External data required	
Weather Mode	--	Auto, Manual-Calm/Moderate/Rough	
Rudder Gain		Auto/1-20 (Manual)	
Counter Rudder		Auto/0-20 (Manual)	
Trim Gain		Auto/1-20 (Manual)	
Trim Adjustment	-5° (port) to +5° (stbd)	--	
Change Course Speed	1-20 deg/s	1-30 deg/s	
Rudder Angle Settings	--	10-45 deg	
Alarm	Heading deviation, Watch	Heading deviation, Cross-track error*, Ship's Speed*, Depth*, Water temperature*, Wind*, Watch, Log Trip* *External data required	
Motor Drive	10 A continuous, 20 A for 5 seconds	25 A continuous, 50 A for 5 seconds	
GESTURE CONTROLLER (NAVipilot-300 only)			
Screen Type/Resolution	1.28" Monochrome TFT LCD, 128 x 128 pixels	--	
Communication Distance	10 m (depending on environmental conditions)	--	
INTERFACE			
Ports	NMEA2000 x1, CAN bus x1 (DBW control), Contact signal x3, Bluetooth (Gesture Controller)	NMEA0183 x2, CAN bus x1, Contact signal x2	
Input	NMEA0183	--	AAM, APB, BOD, BWC, BWR, DBT, DPT, GGA, GLL, GNS, HDG, HDM, HDT, MTW, MWV, ROT, RMB, RMC, THS, TLL, VHW, VTG, VWR, VWT, XTE, ZDA
	NMEA2000	059392/904, 060160/416/928, 061184, 065240, 126208/464/720/992/996, 127237/250/258, 128259, 129025/026/029/283/284/285/538, 130577/818/821/827/841	059392/904, 060928, 061184, 126208/720/992/996, 127250/251/258/488/489, 128259/267, 129025/026/029/033/283/284/285, 130306/310/311/312/313/314/577818/821/827/880
Output	NMEA0183	--	DBT, DPT, GGA, GLL, GNS, HDG, HDM, HDT, MTW, MWV, RMB, RMC, ROT, RSA, VHW, VTG, VWR, VWT, ZDA
	NMEA2000	059392/904, 060928, 126208/464/720/993/996/998, 127237/245, 130816/821/822/823/827/841	059392/904, 060928, 061184, 126208/464/720/992/996, 127237/245/250/251/258, 128259/267, 129025/026/029/033/283/284/285, 130306/310/311/312/822/823/827
ENVIRONMENT			
Temperature		-15°C to +55°C	
Waterproofing	Processor Unit: IP55 Control Unit: IP56 Gesture Controller: IP65/67	Processor Unit: IP20 Control Unit: IP56	
POWER SUPPLY			
Processor Unit	12-24 VDC 0.22 A max. (LEN: 2)	12-24 VDC: 4.0-2.0 A (control unit: 6 sets), excluding pump	
Control Unit	15 VDC 0.29 A max.(LEN: 6)	--	
Gesture Controller	VDC, Dry cell battery (AAA x2)	--	
EQUIPMENT LIST			
Standard	Control Unit (FAP-3011), Processor Unit (FAP-3012), Gesture Controller (GC-001), Installation Materials, Accessories, and Spare Parts	Control Unit (FAP-7011C), Processor Unit (FAP-7002), Rudder Reference Unit (FAP-6112), Integrated Heading Sensor (PG-700), Installation Materials and Spare Parts	
Options	Control Unit (FAP-3011), Gesture Controller (GC-001), Bracket-mount Kits, Cables, Connectors, Junction Box, Pump Unit, Rudder Reference Unit, FPS8 Power Steering Module, Volvo Interface Kit, YAMAHA HM Gateway	Control Units, Flush Mount Kits, Bracket-mount Kits, Cradle, Rudder Reference Units (FAP6112-200), Remote Controllers, Cables, Connectors, Junction Box, Pump Unit, FPS8 Power Steering Module, Volvo Interface Kit (FAP-6300)	

Visit our website to watch guided videos, see screenshots and learn more about features of the NAVipilot-300/711C series.



<https://www.furuno.com/special/en/navipilot/>

A-2107LB
Catalog No. CA000001532

FURUNO ELECTRIC CO., LTD.
Japan www.furuno.com
FURUNO U.S.A., INC.
U.S.A. www.furunousa.com
FURUNO PANAMA S.A.
Republic of Panama www.furuno.com.pa
FURUNO (UK) LIMITED
U.K. www.furuno.co.uk
FURUNO NORGE A/S
Norway www.furuno.no

FURUNO DANMARK A/S
Denmark www.furuno.dk
FURUNO SVERIGE AB
Sweden www.furuno.se
FURUNO FINLAND OY
Finland www.furuno.fi
FURUNO POLSKA Sp. z o.o.
Poland www.furuno.pl
FURUNO DEUTSCHLAND GmbH
Germany www.furuno.de

FURUNO FRANCE S.A.S.
France www.furuno.fr
FURUNO ESPAÑA S.A.
Spain www.furuno.es
FURUNO ITALIA S.R.L.
Italy www.furuno.it
FURUNO HELLAS S.A.
Greece www.furuno.gr
FURUNO (CYPRUS) LTD
Cyprus www.furuno.com.cy

FURUNO EURUS LLC
Russian Federation www.furuno.ru
FURUNO SHANGHAI CO., LTD.
China www.furuno.com/cn
FURUNO CHINA CO., LTD.
Hong Kong www.furuno.com/cn
FURUNO KOREA CO., LTD
Korea
FURUNO SINGAPORE
Singapore www.furuno.sg

PT FURUNO ELECTRIC INDONESIA
Indonesia www.furuno.id
FURUNO ELECTRIC (MALAYSIA) SDN. BHD.
Malaysia www.furuno.com/my
BEWARE OF SIMILAR PRODUCTS
All brand and product names are trademarks, or service marks for their respective holders.
SPECIFICATIONS SUBJECT TO CHANGE WITHOUT NOTICE
Printed in U.S.A.