

# TIGRES - Horizontal Windlass

**1500W**

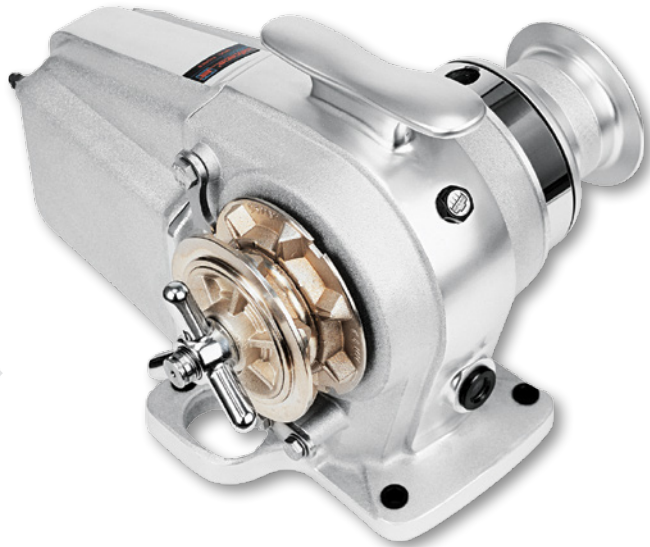

### Main features

- Marine aluminium anodised body
- Independent Gypsy and drum operation
- Manual chain release
- Manual override
- Heavy duty rated IP66 electric motor
- Automatic free fall available as option



**Compatible Gypsies**

Code	Gypsy Size
630968	6 mm, ISO 4565 / DIN 766
630978	7mm, ISO 4565
630994	8 mm, ISO 4565 / DIN 766
631118	10 mm, / DIN 766
631011	10 mm, ISO 4565
631120	3/8 BBB
631122	3/8 PC
631077	5/16 HT

Construction	Anodised Aluminium	
Motor size	1500 W	
Power Supply (V)	12	24
Maximum Pull (kg)	1500	1590
Working load (kg)	190	200
Amps at Working Load (A)	160	90
Line Speed at Working Load (m/min)	14	16
Max Line Speed (m/min)	33	33
Net Weight with Drum (kg)	28	28
Circuit Breaker (available separately)	187333	187332
Control Box	Included in package	

TIGRES		Code	Code
With Drum	8 mm, ISO 4565 / DIN 766	418407	418409
	10 mm, DIN 766	600055	600059
	10 mm, ISO 4565	470060	220290

*\*Non-standard configuration optional gypsies can be supplied separately.  
Please refer to compatible gypsies table*

### Dimensions in mm

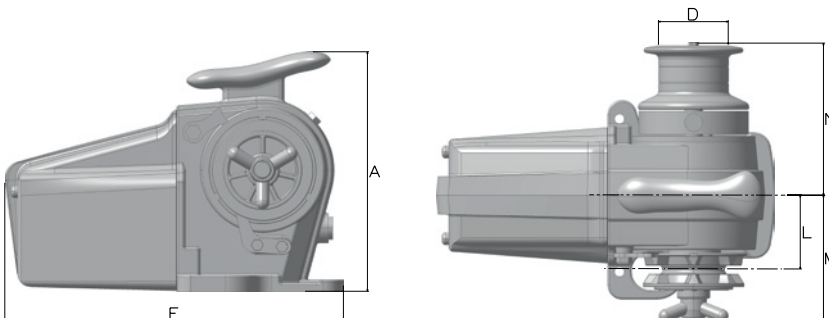

Model	A	D	F	L	M	N
1500W	290	Ø85	415	90	155	185

### Optional Accessories

- Foot Switch
- Control Switch
- Circuit Breaker
- Chain Counter
- Hand Held Control
- Radio Control



**Maintenance Kit for TIGRES**

Code....72050