

VELAIR

Via Milite Ignoto, 8/A 16012
Busalla (GE) It aly

Tel. +39 (0) 10 9620 244/239
Fax +39 (0) 10 9620 333
Web site: www.uflex.it
eMail: service@ultraflexgroup.it

Rev 23/02/06

INSTRUCTION MANUAL

Air Conditioning System

SELF - CONTAINED UNIT

INVERTER VSD Technology

► **Compact i21 VSD**

VELAIR



INDEX

1.0 INTRODUCTION	3
2.0 PACKAGING AND IDENTIFICATION	4
3.0 UNIT DESCRIPTION	5
4.1.1 SAFETY MEASURES	7
4.1.2 PROHIBITIONS	7
4.1.3 RESPONSIBILITY	8
5.0 INSTALLATION.....	8
5.1.1 HYDRAULIC CONNECTIONS	10
5.1.2 AIR DUCTS CONNECTION	13
5.1.3 ELECTRICAL CONNECTION	16
5.1.4 THERMOSTAT BULBS	17
6.0 OPERATING.....	18
6.1.1 ALARMS and troubleshooting	19
7.0 WORKING LIMITS.....	21
8.0 LIMITED WARRANTY	21
9.0 CONTROL PANEL MANUAL	22

We would like first of all to thank you for deciding to grant your preference to our product. We are sure you will be satisfied because it represents the best technology of boat air conditioning. By implementing the suggestions that are contained in this manual, thanks to the product that you have purchased, you can enjoy high thermal comfort with a great energy saving.

Document is confidential by law and may not be copied or transferred to any third party without the express permission of the manufacturer. The manufacturer reserves the right to make changes at any time to their models, without prejudice to the essential features described in this manual.

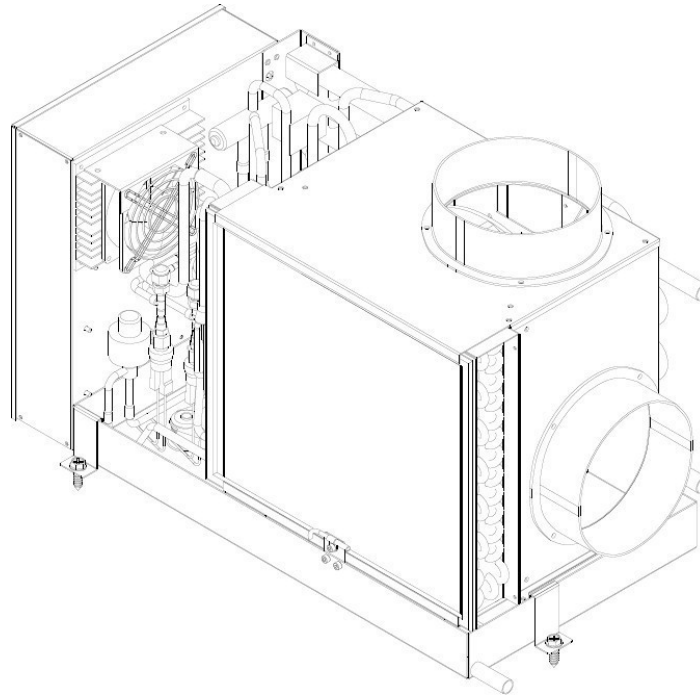

1.0 INTRODUCTION

This manual has been prepared with the aim to give you all the explanations to be able to properly install the unit **SELF-CONTAINED Compact i -Line VSD UNIT** and to better manage the device. Improper installation procedures can result in unsatisfactory performance and / or premature failure of this air conditioning unit. We invite you to read it carefully before operating the product. If there are any statements or procedures described in this manual, that you do not understand, contact UFLEX for assistance:

Phone: +39 (0) 10 9620 244-239

E-mail: service@ultraflexgroup.it

Keep the manual in a dry location to prevent deterioration, for at least 10 years for any future reference. In the interest of product improvement, specifications and design of the VSD SELF-CONTAINED UNIT will be subject to change without giving notice.

NOTE: This unit complies with European directives for EMC 2004/108 / CE.

2.0 PACKAGING AND IDENTIFICATION

The packaging is made of suitable materials to protect the machine from the stress of transport and handling.

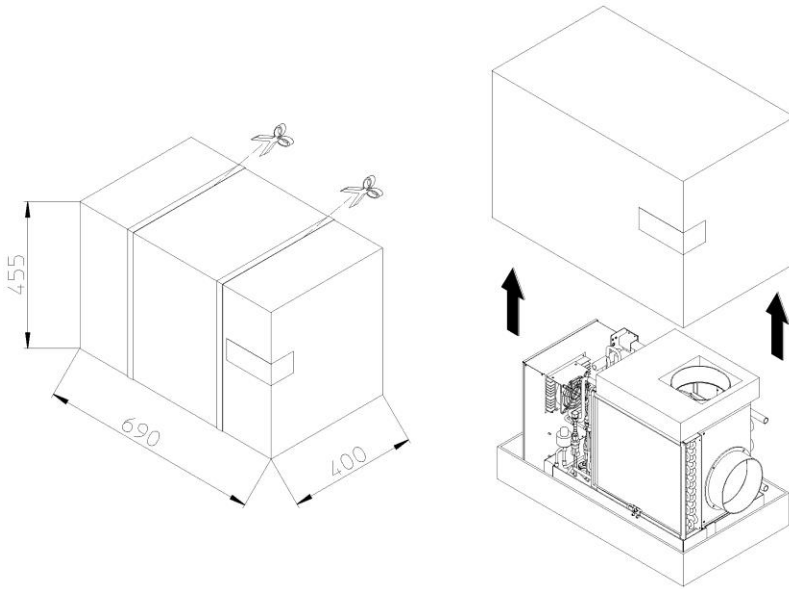

All units are delivered complete and in perfect condition, however, to control the quality of transport services, check the following:

- Upon receipt check if the box is damaged, if that is the case, accept the goods with reservations and keep photographic evidence of any damage found.
- Unpack and check the presence of the individual components.
- Check that all components have not been damaged during transport.

IMPORTANT! Lift the unit avoiding to catch it in sensitive parts such as tubing and air adapters.

When the load is lifted off the ground stay away from below and surrounding area. During transport operations respect the symbols on package and avoid to place in a vertical position the product. In fact, the refrigerator compressor is mounted on vibration dampers, and there may be a shift of the compressor or piping connecting outside their seats. All Aircon Unit are equipped with a pair of lifting handles, during handling and installation of the unit the lifting handles must be used in order to avoid possible damages to the gas piping circuit. Any damage to the gas piping circuit due to a wrong handling of the unit will not be covered by Uflex Warranty.

Each product is identified by a label as below :

		UFLEX srl Via Milite Ignoto, 8A 16012 Busalla (GE)		
Type: Compact i21 VSD		MOD: 24765WW		
Serial number IN15XXXXX	Max cooling/ heating capacity	21000 Btu/h		
Voltage 230 VAC/1/50-60Hz	Max input power	1995 W	Max current	8.9 A
Max sea water flow 800 m3/h	Min sea water flow	20 l/min	Refrigerant R410A	

Contains fluorinated greenhouse gases covered by the Kyoto protocol

3.0 UNIT DESCRIPTION

Brushless DC Inverter Technology

This technology is applied to control the speed of the compressor allowing continuous adjustment of the temperature, in contrast to traditional air conditioning systems where the temperature is controlled by a compressor that can run only at full speed or complete stop.

The system is equipped with a "Brushless DC" variable speed compressor and relative inverter regulator able to change and control the motor speed.

The elimination of intermittent (ON / OFF) cycles allows to increase considerably the energy efficiency, the lifespan of components and increasing the on-board comfort without temperature and relative humidity fluctuations.

By using unit INVERTER "Brushless DC" it is possible install on board a smaller power generator than the one necessary for operating a traditional ON/OFF air conditioning.

Energy Saving (40-50% reduction in electrical demand)

As the air temperature approaches the set point value, the inverter control regulates the capacity by varying smoothly the compressor frequency in order to maintain stable thermal conditions . Thanks to the variable speed operation and the use of "Brushless DC" motor the efficiency is much higher than ON -OFF systems, which must continuously stop and start to maintain the temperature.

In terms of seasonal energy efficiency there is a reduction in electricity consumption by 40-50% compared to traditional air conditioning systems.

The following diagrams give an idea of the operation logic (PID) of this variable speed system.

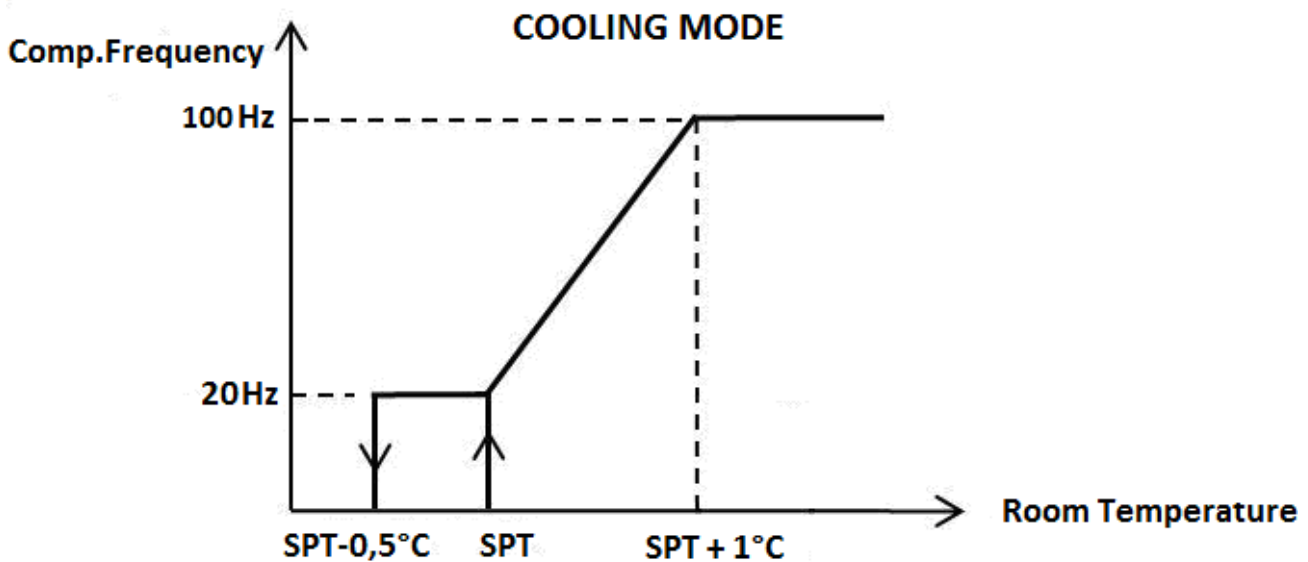

SPT = set point temperature (room)

Room temperature < SPT-0,5°C ➡ **end cooling**

Room temperature < SPT+1°C ➡ **frequency decreasing**

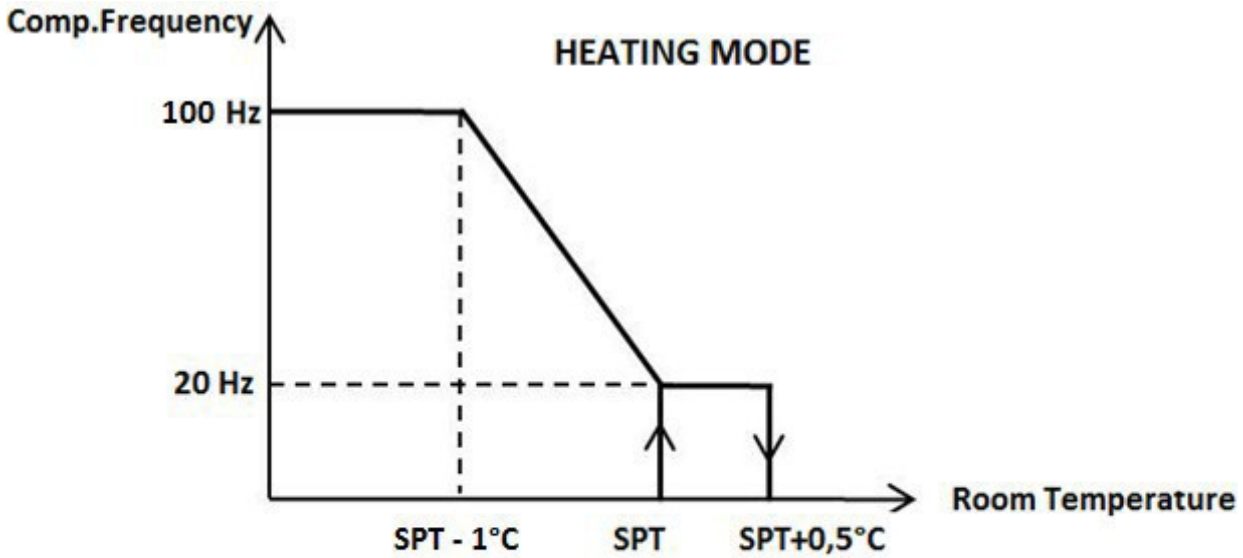

SPT = set point temperature (room)

Room temperature > SPT+0,5°C ➡ end heating

Room temperature > SPT - 1°C ➡ frequency decreasing

Progressive start (no current peaks)

The starting ramp begins at very low frequency (20 Hz) allowing to eliminate peak current at start -up.

Powerful operation

The compressor accelerates to up to 100 HZ (max cooling/heating capacity) after the starting phase, in order to reach very quickly the room temperature set point.

Comfort

The INVERTER air conditioner continuously adjusts the compressor capacity, adapting to changes in the thermal load, and it allows to keep the air temperature stable, always near the Set Point value, without sharp fluctuations.

Thanks to the "Brushless DC " motor and to the sound-absorbing insulation silence is guaranteed during operation.

ECO mode (depending on fan speed selected)

The air conditioner INVERTER can vary its capacity during operation, while the traditional system can only operate with a fixed capacity. By selecting the minimum fan speed, the compressor will automatically switch to low frequency (40 Hz) thus reducing considerably the electrical power consumption. That can be useful for the energy balance in case other electrical appliances are being used simultaneously.

4.0 GENERAL NOTICES

5.0

4.1.1 SAFETY MEASURES

This instruction manual is an integral part of the appliance and therefore must be kept with care and must ALWAYS accompany the appliance even in case of its sale to another owner or user or to a transfer to another plant. In case it is damaged or lost, request another copy from the Technical Service of the area.

During all operations on the device it is necessary to observe the precautions specified in this manual and on the labels attached to the appliance, as well as all the precautions suggested by common sense, and the safety regulations currents at the place of installation.

Please read this manual carefully before proceeding with any operation (installation, maintenance, use) and follow scrupulously the instructions contained in the individual chapters. Failing to comply with the instructions contained in this manual and use the appliance outside the operating limits specified will void the warranty.

Make known these instructions to all staff interested at the machine.

The manufacturer assumes no responsibility for damage to people or property arising from the failure to compliance with the rules contained in this booklet.

In case of replacement of parts, use only original spare parts.

You should always use personal protective elements to perform actions on the devices.

The installation and maintenance of air conditioning equipment may be dangerous because within these devices there are pressurized refrigerant gas and electrical devices. Therefore the installation, initial start -up and subsequent maintenance must be carried out by authorized and qualified personnel only.

In case of leakage of refrigerant fluid, it is mandatory to ventilate the room, considering also that refrigerant fluid when exposed to flame produces toxic gas.

When refilling the system, after eventual leakage and repair, be sure that inside the refrigerant circuit does not enter any substance, such as air, other than the specified refrigerant (R410A). The presence of air or other foreign substances in the circuit of refrigerant may cause an abnormal increase of pressure or breakage, resulting in personal injury.

In the case of water spills from seawater circuit, switch off immediately compressor and seawater pump and shut off Manual Valves in order to stop the seawater flow.

During the cold period if the unit is not in use, drain all the hydraulic circuits connected to the unit, as well as seawater condenser to prevent them from freezing.

Some parts of the appliance produce heat during operation. The room installation must ensure adequate ventilation and proper heat dissipation.

4.1.2 PROHIBITIONS

We remember that the use of products that use electricity and water involves the observance of some basic safety rules such as:

- It is forbidden the use by children and unassisted disabled people.
- Do not touch the appliance when barefoot or with wet or damp parts of the body.

- It is prohibited any operation before disconnecting the unit from the mains supply by moving the power switch to "off".
- Do not modify safety devices or adjustment without permission and instructions from the manufacturer.
- Do not pull, detach or twist the electrical cables coming from the appliance, even if it is disconnected from the mains power supply.
- It is forbidden to open the access panels to the internal parts of the unit without having first disconnected the unit from the mains by putting the system power switch to "OFF position".
- Do not dispose, abandon or leave within the reach of children the packaging material because it can be a potential source of danger.
- It is forbidden to use refrigerant and water pipes for grounding the unit.
- It is forbidden to disperse R-410A into atmosphere: R410A is a fluorinated greenhouse gas, referred to in the Kyoto's Protocol, with a Global Warming Potential (GWP) = 1975.

4.1.3 RESPONSIBILITY

UFLEX S.r.l. disclaims any liability for damage to people, animals or property resulting from the installation, use or maintenance improper of the product, or due to failure of compliance with standards and directives mentioned in this manual.

5.0 INSTALLATION

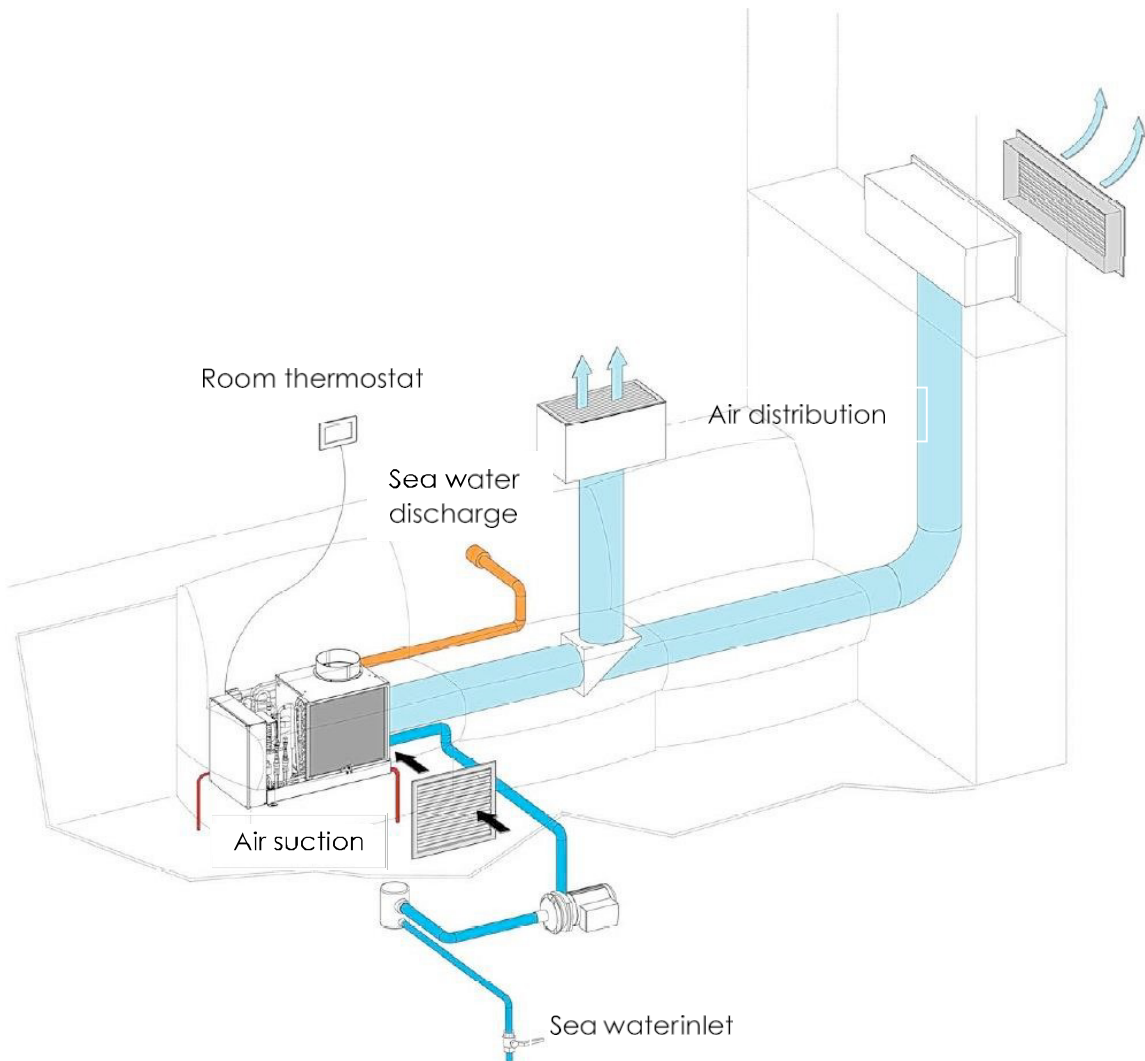

Selection and installation of components are left to the responsibility of the installer who must operate according to the rules of good technique and the legislation in force.

Before connecting the pipes make sure that these do not contain stones, sand, rust, scale or other foreign objects that could cause damage or failure to the system.

To achieve a successful installation and optimum operating performance, carefully follow the instructions provided in this manual.

The failure to apply the rules indicated, which may cause malfunction of the appliance, raise the manufacturer from any form of guarantee and liability for damage caused to people, animals or things.

IMPORTANT! The appliance must be installed in a protected area and in such a way that the accessibility to the unit is possible only by removing the protection by means of a tool.

IMPORTANT! The appliance must be installed in such a way as to facilitate maintenance.

To further increase the comfort, a sound absorption plate is delivered together with the unit. This part could be useful only in heating mode to eliminate the high frequency noise coming from the expansion of refrigerant fluid through the seawater evaporator. However if the unit is located inside a closed space, the plate is useless and it can be easily removed before installation.

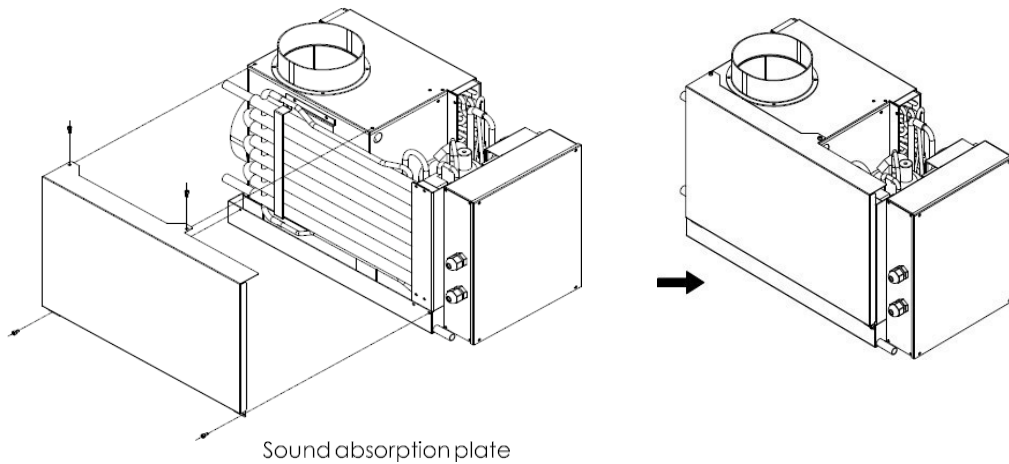

5.1.1 HYDRAULIC CONNECTIONS

The following is a summary of how to install the unit on a sea water circuit and condensate drain:

CORRECT SYSTEM INSTALLATION

CORRECT

STEADY UPWARDFLOW FRQ INLET TO UNIT THEN DOWNWARD TO OUTLET, HOSES DOUBLE CLAMPED

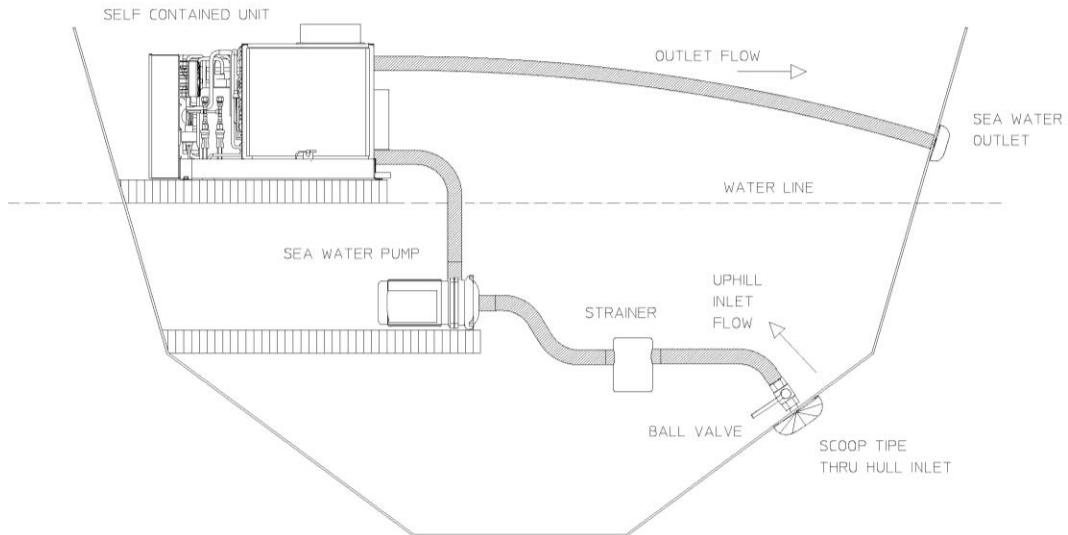

The minimum nominal diameter of the connecting pipes should be 1/2".

If the pump is not self-priming, the through hull inlet must be oriented forw ard in order to have the boat speed helping the priming. No damages can be caused by the water pressure into the filter or propeller.

WRONG SYSTEM INSTALLATION EXAMPLES:

INCORRECT

HOSES MUST NO HAVE KNIKS, LOOPS OR HIGH SPOTS WHERE AIR CAN BE TRAPPED

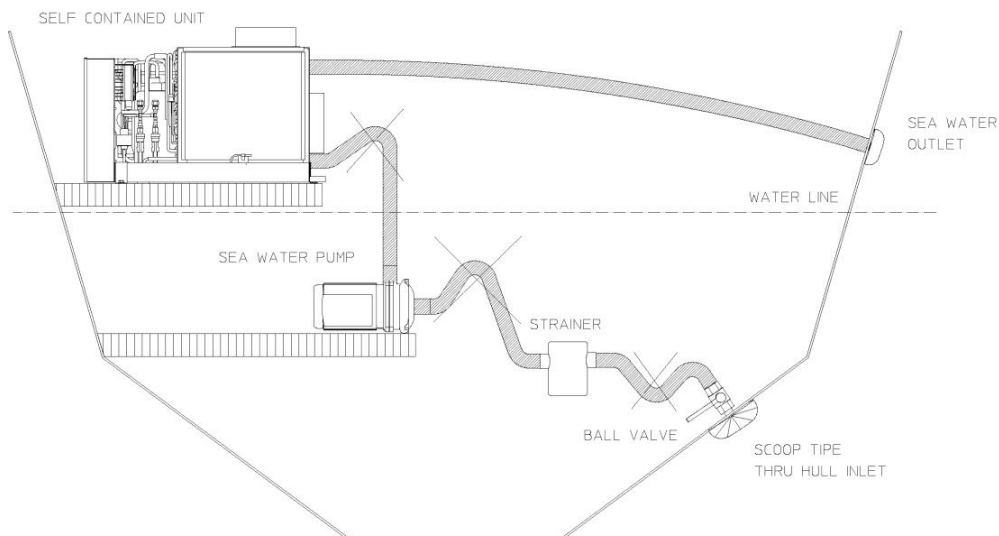

INCORRECT

STRAINER MUST BE BELOW PUMP, HOSES MUST BE DOUBLE CLAMPED

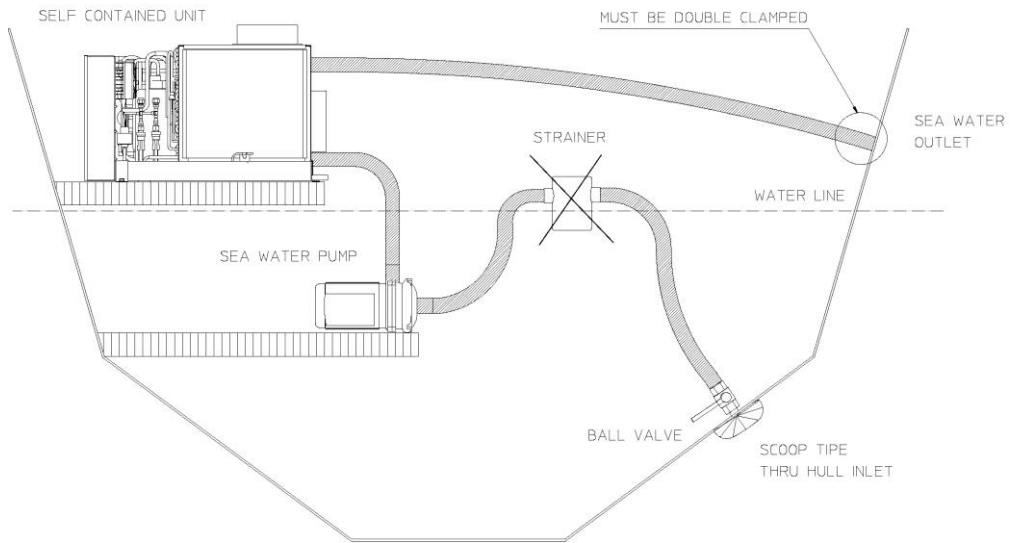

INCORRECT

PUMP AND STRAINER MUST BE BELOW WATER LINE

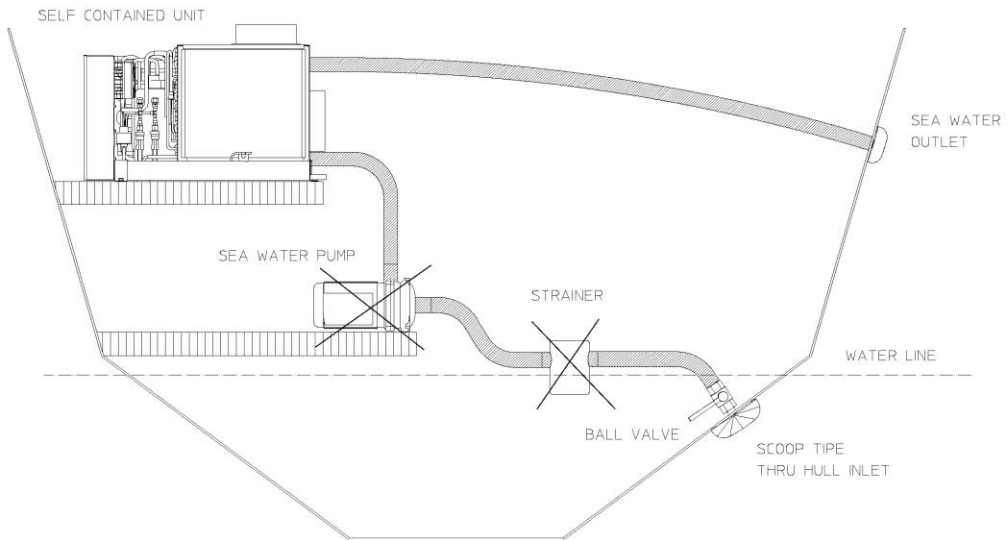

SEA WATER CIRCUIT

Installing seawater electric-pump

The sea water electric-pump is needed to circulate the amount of water required in the heat exchanger. This pump is normally centrifugal type and not self-priming type, so it must be mounted so that it is always at least 20 cm below the waterline. The electric-pump should be fixed through silent blocks possibly in a sound insulated environment.

IMPORTANT! Turn off the air conditioning always when the sea is very rough in order to avoid pump losing priming.

It is required a sea water filter between the sea water intake and electric-pump, in order to protect it from any foreign matter. Failure to install a sea water filter void the warranty of the pump and the unit.

Seawater circuit must be installed with a slope upwards: from the seawater intake, through the filter at the pump inlet to the condenser unit compact entrance.

The unit overboard discharge must be installed as close as possible to the waterline to reduce noise and to be able to check visually the flow / output of the water circuit running.

Self-contained installation

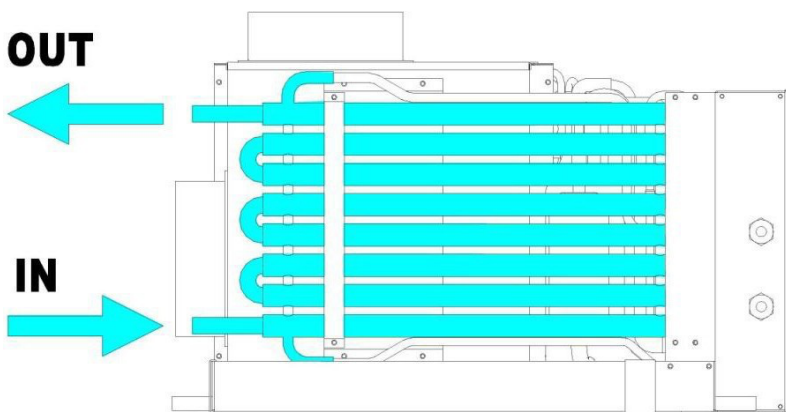

Connect the self-contained heat exchanger unit in the following manner:

NOTE: to allow the maintenance or repair operations it is essential that each hydraulic connection is provided with the respective shut off valve.

DRAIN

The air treatment involves the separation of condensate water from humidity of air treated. This condensate must be discharged in the bilge or in a special tank. Since while operating the air conditioner sucks and then creates a slight vacuum in the environment, the drain pipe that goes directly or in the bilge or in a tank, it could suck it up and bring unpleasant smells into the cabin. To avoid this, it is appropriate to make a trap for blocking the air.

DRAIN DISCHARGE

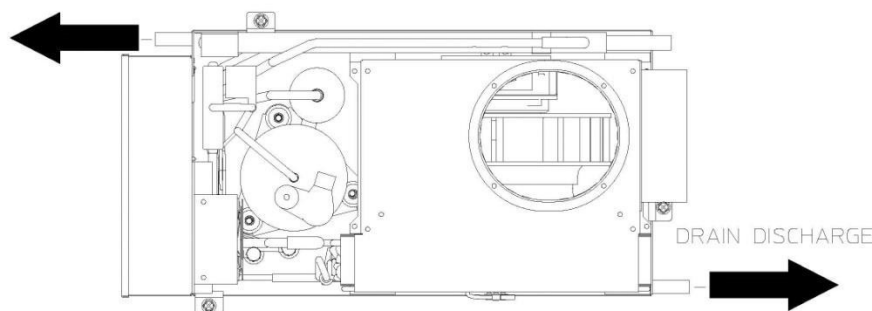

NOTE: The direct discharge at side is not recommended because of sucking bad smells from the outside caused by the exhaust gas of its own or other engines.

Each self-contained unit has two outlets, and it is recommended to use both in order to evacuate quickly the water from the drain pan.

5.1.2 AIR DUCTS CONNECTION

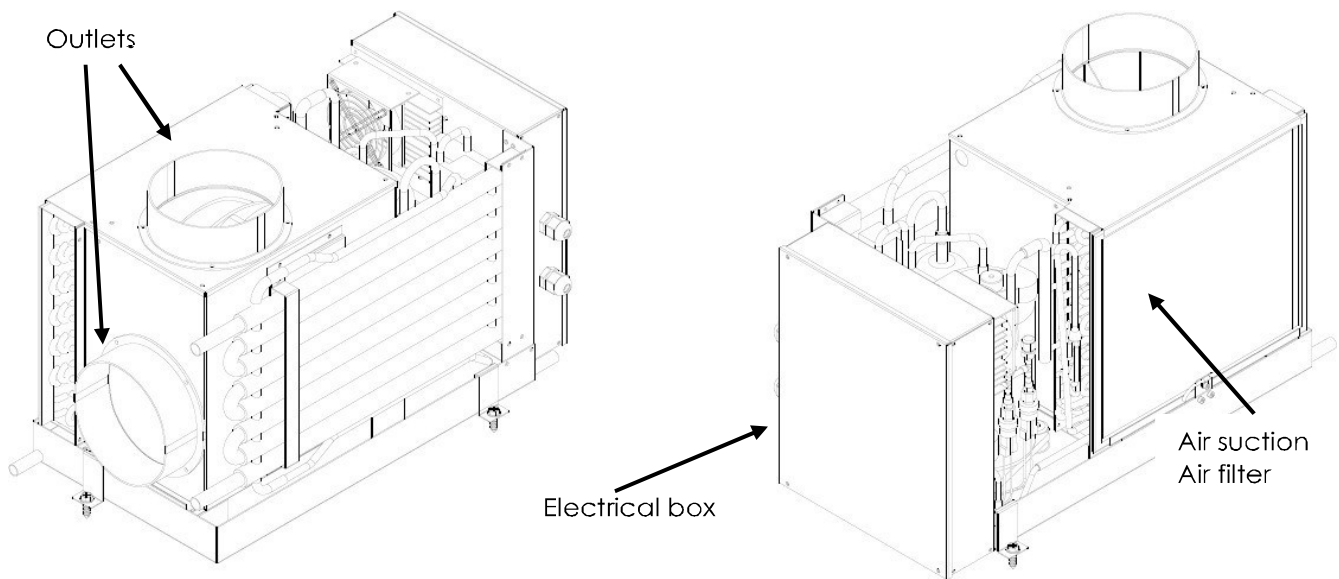

IMPORTANT! Both outlet fittings can be ducted allowing the highest air flow rate, however in case of restricted space for installation, only one outlet can be ducted while the other shall be closed.

The diameter of the ducts should not be less than the diameter of the outlet nozzles.

- SELF CONTAINED Compact i21 VSD (up to 21.000 BTU/h) ducts diameter 150mm

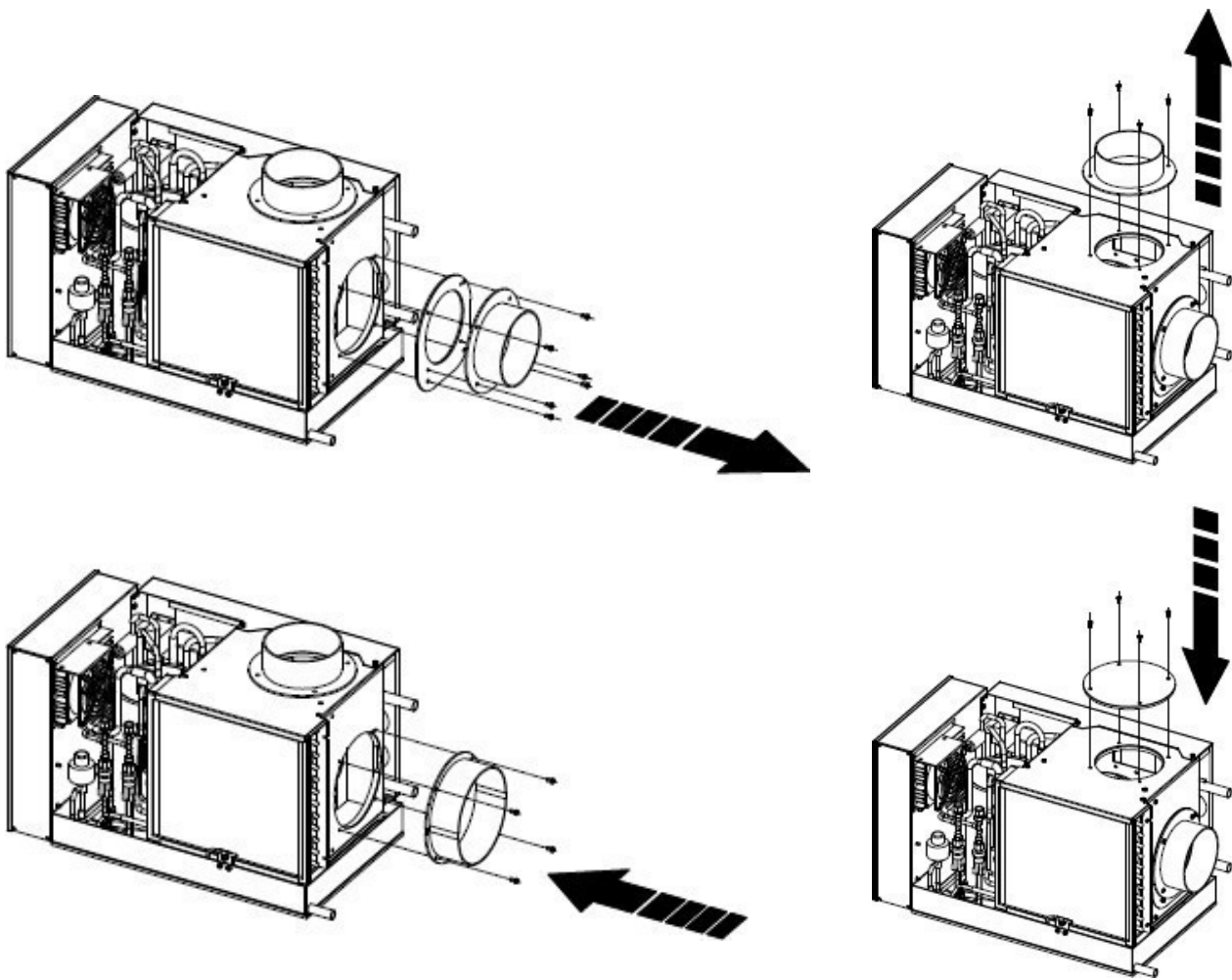

Suction

The ambient air is sucked through one or more grids of appropriate size. The grid dimensions should respect the suction area of the unit.

Air distribution

The system need a correct air flow in order to work efficiently. It is therefore important to get the correct distribution without bottlenecks , by maintaining the original nozzle diameter and not exceeding the recommended length of pipes.

The air ducts should be insulated type and must be well stretched to allow a good air flow .

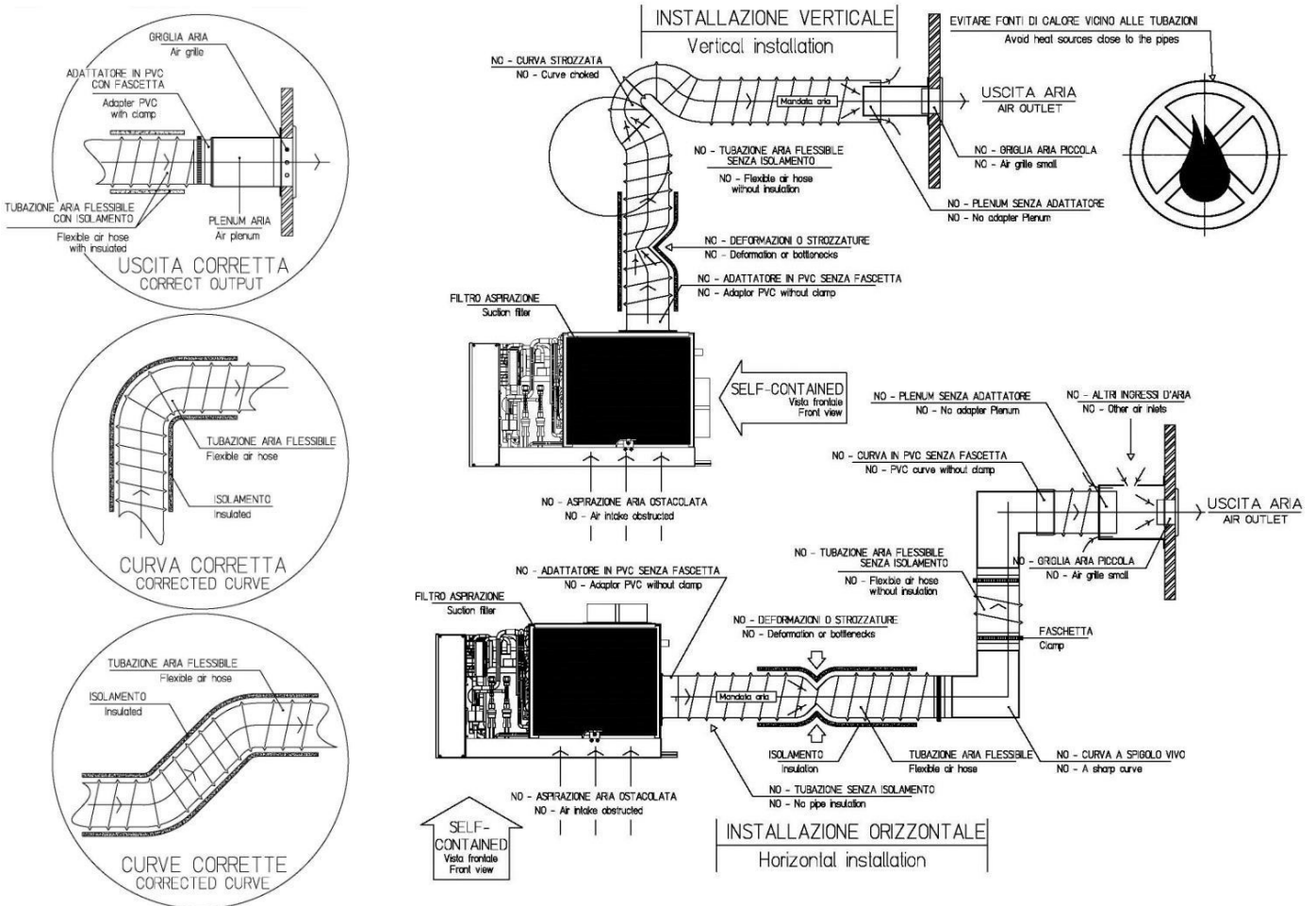

AIR FILTER

The air conditioner sucks air from the environment through an air-gas exchanger equipped with aluminium fins having small pitch. A filter must be located upstream the exchanger in order to protect it from dust.

NOTE: the filter must be easy reachable to be extracted for the normal operations of cleaning and / or replacement whenever required.

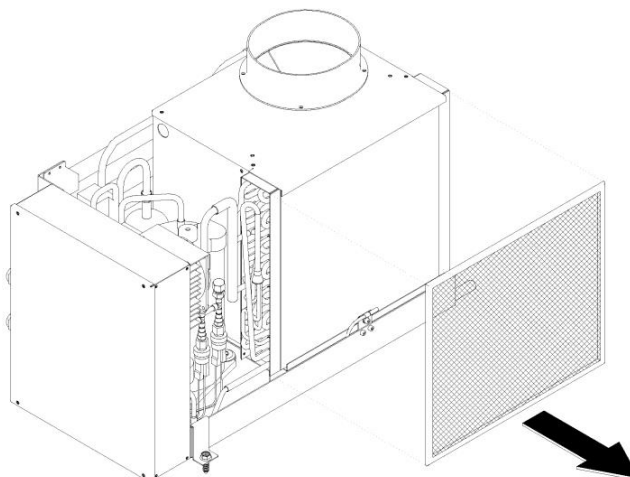

5.1.3 ELECTRICAL CONNECTION

Warning

It is important that the electrical system is done according to the rules, respecting the data provided in chapter Technical data and it shall be properly grounded.

FIXING

The electrical box is delivered fixed on the self-contained unit, however in case of limited space during installation it can be detached (by 3 screws) and fixed elsewhere at a max distance of 0.6 m. It must be installed inside a space provided with suitable ventilation.

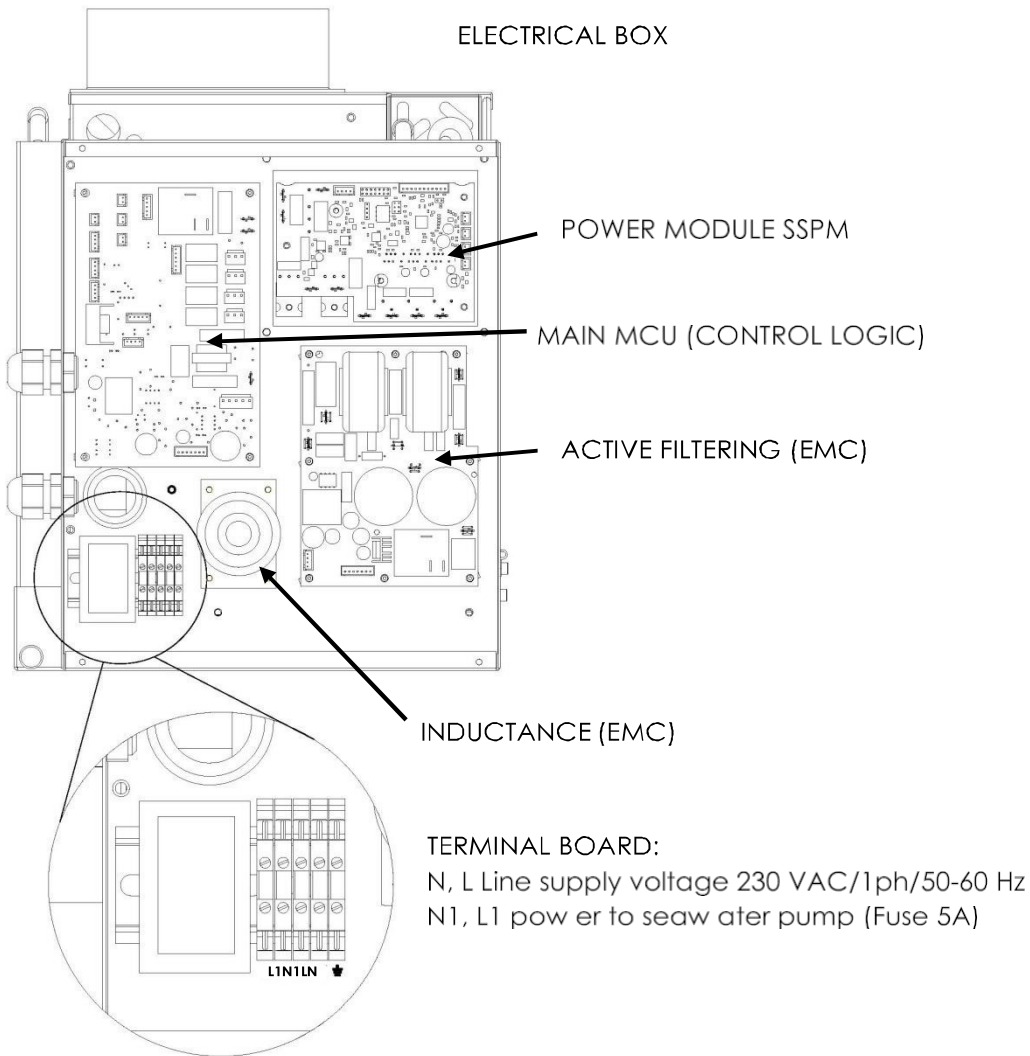

5.1.4 THERMOSTAT BULBS

A thermostat bulb is fixed to the drain pan through a bracket and located near the unit air suction.

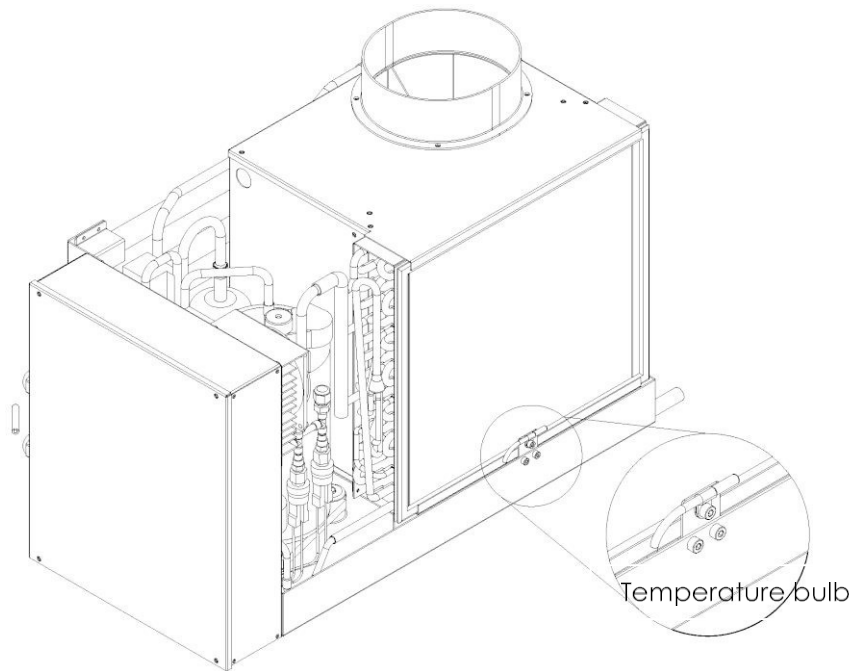

6.0 OPERATING

From remote controller it is possible to select the On / Off mode, the cooling, heating mode, to change the set point temperature (+ / -), to select the fan speed (min, med, max, auto).

The room thermostat must be installed in a proper position, away from direct heat source. The set point temperature and real value are shown on the thermostat display.

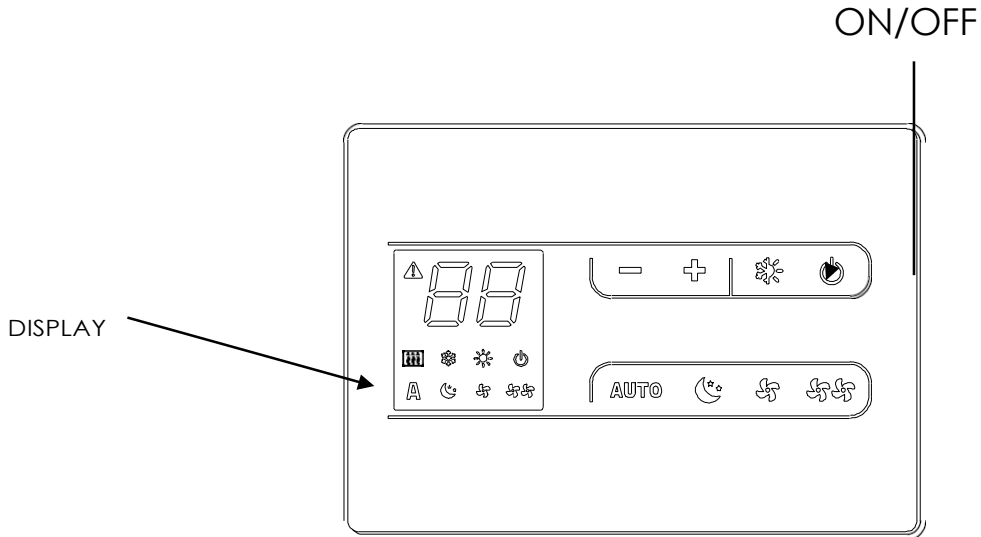

The room thermostat has to be connected with the PCB through the 5 m cable (supplied with the unit).

For the user interface display operation please read carefully the specific instructions attached

Control Panel PIN Out



6.1.1 ALARMS and troubleshooting

In case of failure the following codes are shown on two digits display in the electrical box : E1 : Room temperature: sensor failure;

E2 : Evaporator coil temperature: sensor failure; E3 : Seawater inlet temperature: sensor failure; E4 : Condenser temperature: sensor failure; E5 : Indoor DC Fan failure;

E7: Communication error between main MCU and room thermostat; LP: Low Pressure switch alarm;
HP: High Pressure switch alarm;

LT: low evaporator temperature in heating mode

In case of alarm from E1 to E7 please try to switch OFF the unit and then ON again, if the problem persists call a Uflex authorized service.

HP alarm in cooling mode could be due to obstructed seawater circuit, or to the seawater pump not working properly (e.g. thermal load protection). Please check visually the seawater discharge overboard, and in case of poor water flow, check and clean all the involved parts.

In case of HP alarm appears in heating mode, the air flow through the air outlet could be too low. Please check all the ducts are not obstructed somewhere. Also, the air suction filter, if dirty, could cause high pressure, provide then to clean it before restarting the unit.

LP alarm is most commonly due to a consistent leakage of refrigerant, check the refrigerating circuit for leakages.

In case of LT alarm, the problem could be due to poor seawater circulation or seawater temperature too low (below 5°C). Please check first the seawater flow as above specified.

7.0 WORKING LIMITS

The unit operates correctly within the following ranges:

- ✓ Summer cooling mode: 15°C < sea water temperature < 40°C
- ✓ Winter heating mode: 5°C < sea water temperature < 20°C

Should working conditions be out of these ranges, in your particular application, please contact Uflex before installation in order to find a suitable solution.

Localized situations: in some regions, it is common to experience a tremendous presence of jellyfish or seaweed concentrated in back bay marinas for some periods of time. This can clog strainers, water pumps and heat exchangers in a little while, causing shut-down faults and sometimes equipment damage. In such particular conditions, please seek for the advice of a local Uflex service representative. Any possible modification to the overall system (self-contained, pumps, strainers, etc.) that could overtake the problem must be approved by Uflex, otherwise warranty coverage will expire.

The standard pump is not self-priming: any damage incurred due to a pump running dry is not covered under warranty. Air conditioning system must be switched off, as well as pumps, whenever there is a risk of pump losing priming, due to particular seawater conditions related to the boat type and its speed. The compressor could be damaged if the seawater flow through the heat exchanger is considerably reduced.

This air conditioning system is designed to work under normal operation conditions. Where failure or malfunctions could lead to an abnormal operating condition that could cause injury or damage to any equipment or other property, additional precautions must be designed into the control system. Other

devices (limit or safety control) or systems intended to warn of, or protect against failure or malfunction, must be incorporated into and maintained as part of the system .

8.0 LIMITED WARRANTY

The Uflex warranty policy is extended to cover the VELAIR Marine Air Conditioning products manufactured or supplied by Uflex srl.

Uflex warrants that products are free from defects in material or workmanship for their normal use for a period of two (2) years.

This limited warranty is to be administered and serviced through a Uflex Authorized Dealer/Service in accordance with the Uflex warranty policy.

As alternative, the defective product should be returned freight prepaid to the Uflex facility and must be accompanied by an Uflex issued Return Goods Authorization number. Upon receipt, the product will be examined to determine the cause of defect. If the product is determined to have a defect in workmanship or material, it will be repaired or replaced at the Uflex discretion. And then shipped back ex works.

This guarantee does not cover labor, nor installation/deinstallation time.

All parts repaired or replaced under warranty condition are guaranteed to be free from defects for 90 days after repair/replace or the remainder of the original warranty, whichever is longer.

To locate the nearest Uflex Authorized Dealer/Service please call:

- > Europe: Uflex at +39-010-9620.239 /244
- > USA: Uflex USA at +01 (941) 351-2628
- > Rest of the World: Uflex at +39-010-9620.239 /244

or visit our web site at: www.uflex.it and www.uflexusa.com

8.1.1 Installation / Validation & Commissioning

The Uflex Marine Air Conditioning Products have to be installed by authorized installers or the installation has to be reviewed and approved by an authorized installer.

All installation/application releases should be commissioned, validated and documented. In case of OEM installations this applies only for the first released representative application.

For commissioning and validating procedure, please write to the Uflex Team (service@ultraflexgroup.it) or refer to your Uflex service/dealer. They will get in touch with Uflex Team

8.1.2 Limitations and Exclusions

This warranty is limited to repair & replacement only. It does not cover:

- ✓ Claims for direct or indirect Damages
- ✓ Failure of the Uflex equipment due to normal wear, accident, misuse, abuse, lack of reasonable and necessary maintenance, unauthorized installation or repair by the end-customer
- ✓ Transportation damages. This should be claimed directly with the forwarding company.
- ✓ Repair costs due to failure of Uflex equipment due to negligence, improper installation or non-respecting the installation guidelines (installer fault) will not be refunded
- ✓ Limited warranty is extended only to the original application and is not transferable.
- ✓ Any intervention by a third part not specifically and previously authorized by Uflex to repair, will void the Uflex warranty and it will not be reimbursed.

8.1.3 Owners Responsibilities

The responsibility of the owner of the equipment includes the following:

1. Operate the equipment according to the manufacturer's instructions.
2. Perform regularly maintenance.
3. Provide easy accessibility for service.
4. Check and reset circuit breakers and fuses before calling for service.
5. Keep the unit clean and free of dirt.
6. Keep the condenser coil free of sediment and scale.
7. Keep clean the air filter on heat exchanger.
8. Proof of purchase is required for all units.
9. Ask the installer of your Uflex air conditioning system or your Uflex dealer for a copy of the Validation Report.

9.0 CONTROL PANEL MANUAL

Compliance

This unit complies with the following European Directives:

- Low voltage 2014/35/EU;
- Electro-magnetic compatibility 2014/30/EU;

Symbols

The pictograms in the next chapter provide the necessary information for correct, safe use of the appliance in a rapid,

unmistakable way.

Editorial pictograms

User

- Refers to pages containing instructions or information for the user.

Installer

- Refers to pages containing instructions or information for the installer.

Service

for the CUSTOMER TECHNICAL ASSISTANCE SERVICE installer.

Safety pictograms

Warning

- The operation described may cause physical harm if not carried out in accordance with safety regulations.

Dangerous electrical current

- Make personnel aware that the operation described may lead to electrical shocks if not carried out in accordance with safety regulations.

High temperature danger

- Of safety regulations, the risk of burns caused by contact with components with high temperatures.

Prohibition

- Refers to prohibited actions.

-
- Refers to pages containing instructions or information

Velair touch control panel with room probe

Velair touch control panel is an electronic thermostat with a room temperature probe for controlling VELAIR air conditioning units, both On-Off and VSD – Inverter type of units
The control panel has a memory, so settings will not be lost if the appliance is switched off or in the power supply is cut.

⚠ After 20 seconds from the last action, the panel brightness will be reduced and the room temperature will appear on the display. Press any key to restore maximum brightness.



9.2 Display

Any statuses and alarms are also shown on the display by using 8 specific symbols:

	Automatic operation
	Medium ventilation speed
	Maximum ventilation speed
	Minimum ventilation speed
	Heating on

	Cooling on
	Alarm indicator (solid light)
	Panel off indicator





8.3 Key function

The various functions are set using 8 backlit keys:





	Temp + is for increasing the set temperature
	Temp - is for decreasing the set temperature
	Heating / Cooling: for changing the operation mode between heating and cooling
AUTO	Sets the regulation ventilation speed between a minimum and maximum value to an entirely automatic mode

	Minimum speed operation: limits ventilation speed to a contained level and the set temperature is adjusted automatically.
	Maximum speed operation: Allows for the maximum ventilation speed to be set
	ON/Stand-By: for activating the device or for putting it in stand-by.
	Medium speed: limits ventilation speed to a more contained value

9.2	Display	10
9.3	Key function	10
9.4	General switch-on	11
9.5	Activation	11
9.6	Heating/cooling operation modes setting	11
9.7	Stand by	11
9.8	Temperature selection	11
9.9	Automatic operation.	12
9.10	Operation at medium ventilation speed	12
9.11	Operation at minimum ventilation speed	12
9.12	Operation at maximum ventilation speed	12
9.13	Key lock	12
9.14	Reduce brightness to minimum	12
9.15	Deactivation	13
9.16	Room temperature probe regulation offset	13

		Display
	Press the ON Stand-by key	From off to on
9.5 General On Switch		
	<p>In order to manage the unit via the control panel, this must be connected to the conditioner</p> <p>If a general switch is installed on the power line, this must be switched on.</p> <p>Select one of the 4 operating modes by pressing the relative key.</p>	<p>Turning the general switch</p> 
Activation		
	Turn on the device	

9.7 Heating/cooling operation modes setting

Key	Operation	Display
	Keep the Heating / Cooling key pressed for approx. 2 seconds to change the mode between heating and cooling, which is indicated by the 2 symbols that appear if heating or cooling is active.	
	When heating, the symbol displays when the set point is higher than ambient temperature, both are off when the set point is lower.	
	When cooling, the symbol displays when the set point is lower than ambient temperature, both are off when the set point is higher.	

9.8 Stand By

Key	Operation	Display
	Press and hold the ON Stand-By key for approx. 2 seconds. No illuminated signals on the display at all means that the system is in stand-by (no operation).	Off

The adjustment range is from 16 to 31°C in intervals of 0.5°C.

The controller is very precise - set it to the required value and wait for the controller to regulate itself according to the actual room temperature detected.



9.10 Automatic operation

Key	Operation	Display
AUTO	Press and hold the AUTO key. The function being activated is indicated by the relevant symbol appearing on the display.	A



Ventilation speed adjustment is carried out automatically between the minimum and maximum values, according to the distance of the actual room temperature from the set

point, according to a PI-type algorithm.

Medium ventilation speed operation

Key	Operation	Display
	Press and hold the medium speed key. The function being activated is indicated by the relevant symbol appearing on the display.	



Ventilation speed is limited to a contained medium value.

Key	Operation	Display
	Press and hold the minimum speed operation key. The function being activated is indicated by the relevant symbol appearing on the display.	

By selecting this mode, ventilation speed is limited to a minimum level and the set temperature is adjusted automatically, as follows:

- decreases by 1°C after one hour and by another degree

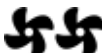
after two hours in heating mode;
- increases by 1°C after one hour and by another degree after two hours in cooling mode;

Key	Operation	Display
	Press and hold the Max Operation key. The function being activated is indicated by the relevant symbol appearing on the display.	

In this operation mode, the maximum possible power level is activated whether heating or cooling. Once the desired room temperature is reached, we recommend selecting one of the other 3 operation modes

for increased comfort and sound levels.

9.13 Key lock

Key	Operation	Display
+	By pressing both the + and - keys for 3 seconds, all keys are locked locally, and this is indicated by "bL" appearing on the display. All actions are disabled to the user and whenever any key is pressed, "LOC" will appear. To unlock the keys, repeat the sequence.	bL
-		

9.14 Reduce brightness to minimum

After 20 seconds from the last action, the panel brightness will be reduced for improved night-time comfort, and the room temperature will appear on the display.

If this brightness is still disturbing, the display can be

switched off completely.

Key	Operation	Display
+	With the display off, press and hold the + key for 5 seconds until "01" is displayed. Use the - key to change the value to 00 and wait 20 seconds to check the setting has been accepted.	00
9.10	Automatic operation	

9.15 Deactivation

Key	Operation	Display
	Press and hold the ON Stand-By key for approx. 2 seconds. No illuminated signals on the display at all means that the system is in stand-by (no operation).	Off

The controller also ensures anti freezing when in stand-by.

By using this function, the value displayed can be adjusted in a range from -9 to +12 K in intervals of 0.1°C.

Use this adjustment with care, and only after having

actually detected a discrepancy compared with the actual room temperature using a reliable device!

Key	Operation	Display
	With the display off, press and hold the - key for 5 seconds to access the menu which allows adjustment (using the + and - keys) of the AIR probe offset displayed, from -9 to +12 K in 0.1 K intervals. After 20 seconds from the last action, the panel switches off and the setting is stored.	00.0

