

The background features a complex pattern of thin, white, curved lines on a solid black field. The lines are arranged in a way that creates a sense of depth and movement, with some lines intersecting to form diamond-like shapes. The overall aesthetic is modern and minimalist.

Excess 14

PRODUCT GUIDE

Dear Dealer,

This document contains all the essential information you will need to talk about Excess brand and the EXCESS 14 :

- 01. SALES
- 02. OPTIONS
- 03. CHART COLORS
- 04. TECHNICAL DATA

This document is a professional tool for your use only. Thank you to not forward it directly to clients but use it to improve your personal knowledge and to perform during client meetings.

This tool will be regularly upgraded according to model year changes and supplier evolutions. Please check regularly for updates. Last upgrade is indicated at the bottom of this page.

The document refers to standard equipment from Price List C2023.

Enjoy your reading !

The Excess team

Indice A
SEPTEMBER 2022 EDITION

01 SALES



1. EXCESS BRAND
2. KEY CLIENT BENEFIT
3. SAILING EXPERIENCE
4. OUTSIDE EXPERIENCE
5. INSIDE EXPERIENCE

02 OPTIONS



1. SAIL AWAY PACK
2. SAILING EXPERIENCE
3. OUTSIDE EXPERIENCE
4. TECHNICAL EQUIPMENT
5. INSIDE EXPERIENCE

03 CHART COLORS



1. INTERIOR STANDARD
2. INTERIOR OPTIONS
3. TAILORED INTERIOR PACKS
4. EXTERIOR

04 TECHNICAL DATA



1. SPECIFICATIONS
2. ELECTRICITY
3. FLUIDS
4. LAYOUTS
5. VPP
6. BERTH-MATTRESSES

01

SALES

01 EXCESS BRAND

02 KEY CLIENT BENEFITS

03 SAILING EXPERIENCE

04 OUTSIDE EXPERIENCE

05 INSIDE EXPERIENCE

This chapter contains all the essential information you will need to talk about product overview and key client benefits. You'll also find standard equipment details.



01

EXCESS BRAND POSITIONING

1. Brand role
2. Brand values

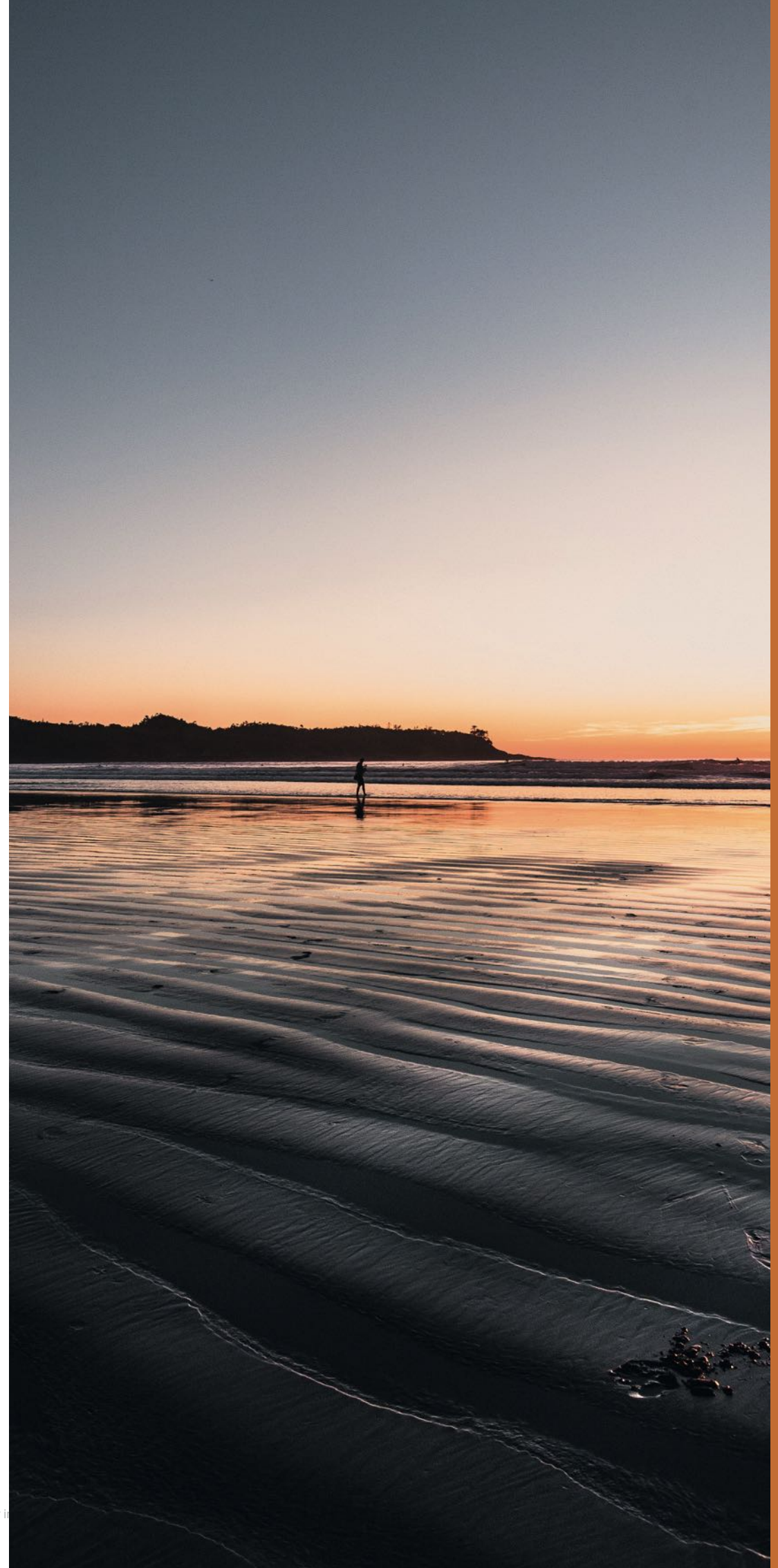

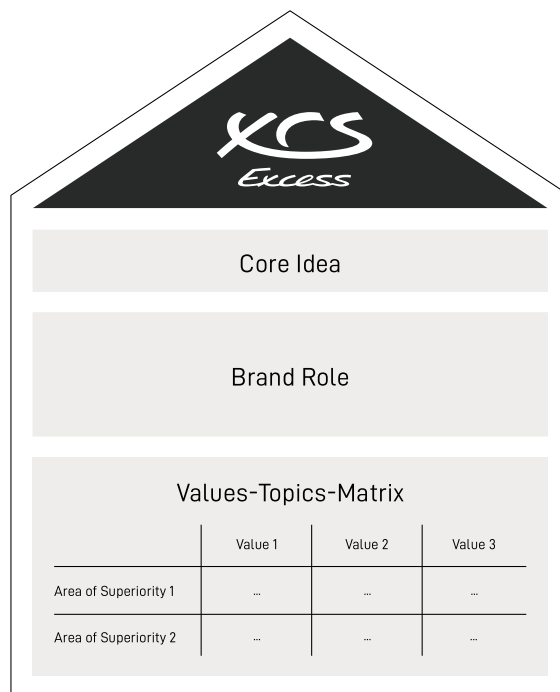

Core Idea

YOUR GATEWAY TO SENSATIONS

Brand Role

At Excess, **breaking new ground** isn't revolutionary. It's simply what we do. Unique cruising catamarans with a **dynamic design and our disruptive attitude** set us apart. This is how we offer **the thrill of sailing without sacrificing comfort**. Thereby, we are your gateway for exciting activities on, in, and around the sea. Created for sailors looking for their next adventure.

Areas of Superiority

Sailing experience
360° Excitement

Brand Values

Dynamic | Fresh | Genuine

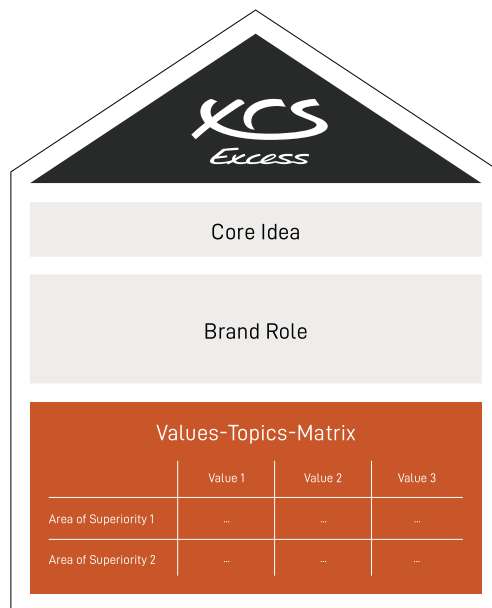

	Dynamic	Fresh	Genuine
Sailing experience	<ul style="list-style-type: none"> - The dynamic quality of our boats determines the design and features of our boats (such as sail area, helm design, etc.). - Our catamarans are built to be suitable for beginners as well as professionals. 	<ul style="list-style-type: none"> - We are not afraid to break new ground and recognize trends as one of the first. - Our innovative features bring a fresh breeze to the catamaran industry. - We support our customers with a worldwide service network on any issues that may arise. 	<ul style="list-style-type: none"> - We are true sailing enthusiasts and share our enthusiasm with each other and our customers. - We are open to honest feedback and value direct interaction with our customers. (e.g. Excess Lab).
360° Excitement	<ul style="list-style-type: none"> - We do not compromise on comfort and create space for sharing experiences. - We create the ideal basis for a variety of thrilling activities on, in and around the sea. 	<ul style="list-style-type: none"> - We design our catamarans with modern materials displaying bright, clear colors for a fresh look and feel. - Our messages and images stand out from the crowd with their refreshing touch. 	<ul style="list-style-type: none"> - On our catamarans you stay in full contact – with your inner self as well as the rudders. - We create real, fulfilling experiences that have a lasting effect. - We stand for fun, true experiences along the entire customer journey – from the purchase to the final setting of the sails.

02

KEY CLIENT BENEFITS



PURE CONCENTRATION OF EXCESS DNA

- 1.** The embodiment of Excess DNA: a **fun and playful cruising sailboat** with sleek lines.
- 2. Innovative architecture:** unbiased research to find 'out of the box' solutions.
- 3. More sensations** and everything you'd expect of a cruising boat!
- 4.** Designed around a **layout unseen** on the market, both in the Owner's version and in the Charter version.





KCB 1: DYNAMIC LOOK

Sporty design with long inverted and thin hulls.

- New: Excess 14 has **inverted and inclined bows** for more fun!

KCB 1: 360° VISION

Complete transparency for perfect **360° vision and bright interior**

KCB 1: SLEEK LINES

Sleek lines and great balance. Excess 14 benefits from low boom and profil, reduced windage thanks to lower freeboard, taut lines and redesigned hull windows. All reinforce Excess distinctive look!



KCB 1: PULSE LINE

Elegant yet **modern PULSE LINE hull decoration** from famous racing boat decorator Isabelle Keller

KCB 1: PULSE LINE

Now well-known, visual signature both on the water and in the ports, of the **orange furler and the grey sails**.

DID YOU KNOW?

- Isabelle Keller has always drawn. Her passion for sailing naturally led her to focus on sailboats: "I have sailed a lot; I have experienced ocean racing and great adventures like the Transats and the Vendée Globe (VG) from the inside". She's been decorating VG monohulls for many years; Safran, must-see Vache qui rit® or Classe Figaro sailboats. She has drawn for Bertrand de Broc, Kito de Pavant, Jean le Cam and François Gabart (2012 winner). Today Isabelle has decorated more than 50 boats.



Isabelle Keller

KCB 2: LIGHTER THAN EVER... LESS IS MORE!

An in-depth work never done before with one motto: weight, weight, weight!

- FEA study, usually reserved for racing yachts,
- Low density balsa core, infusion coachroof, foam sandwich, carbon reinforcements, etc. for an optimized structure
- Development and integration of the equipments and materials strictly necessary, without adding complexity.
- Lightship displacement [Mlc]: 12,800 kg | 28,219 lbs

KCB 2: GOOD RATIO & GOOD LOOKS

- The short platform moved as aft as never did before, aft-set coachroof, forward stepped mast: a modern rig and unobstructed salon
- The very long bows and short coachroof not only grants a better HL|PL ratio, but also better looks!

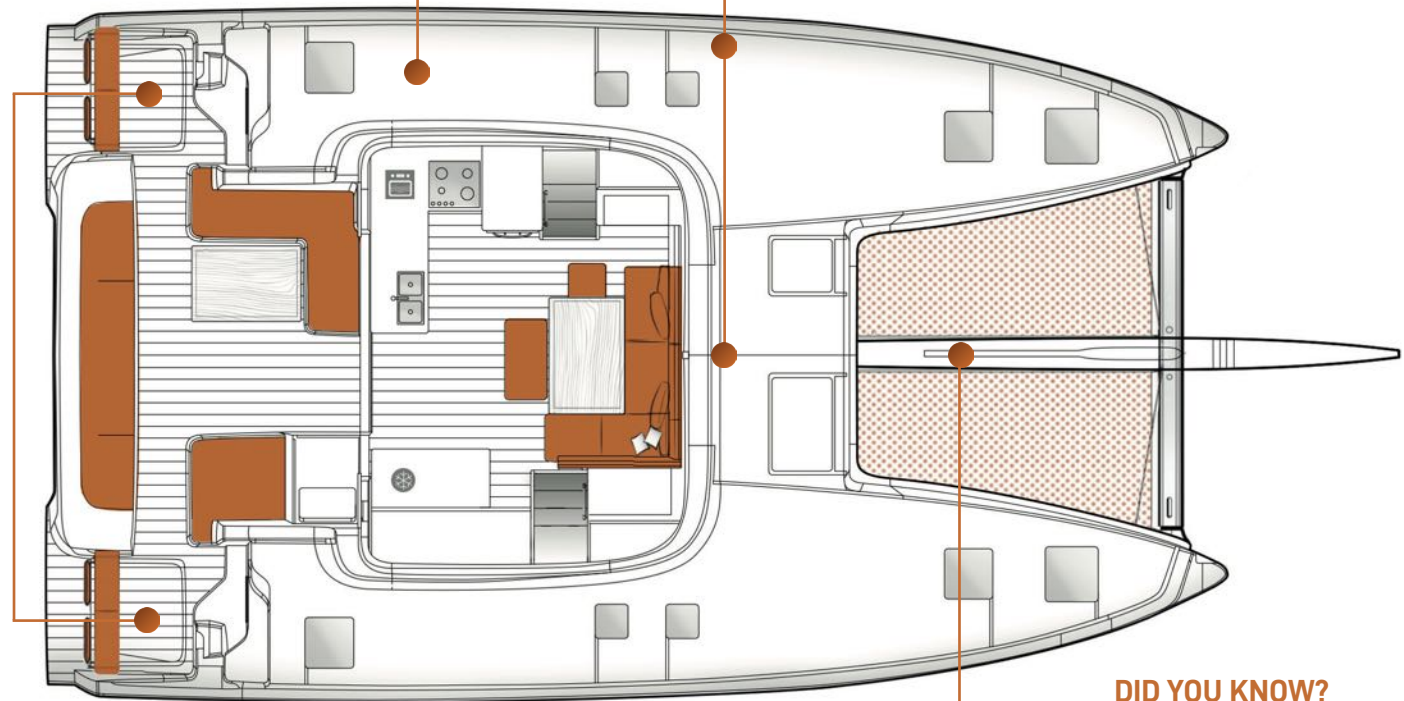

KCB 1: AFT TWIN HELM STATION: THRILLING SENSATIONS

- Helm stations right at the stern, with a direct contact with the rudders and a steering system with textile lines. Guarantee of both feel and efficiency.
- Sail trimming right has never been that easy, even the overlapping genoa fully trimmable from the helm station!
- Ideal view of the sails, the sea and the bows
- 2 engines with 2 helm stations aft, allow perfect control of the boat
- Thanks to collaboration with VPLP, world leader in racing multihull design, Excess 14 have benefited from an understanding of ocean racing, from naval architects owning most records.

KCB 2: INNOVATIVE ARCHITECTURAL SOLUTIONS:

- Forward-set rig, square top mainsail, and large **overlapping genoa** [new!] to optimize the sail area to displacement ratio
- Non-immersed forefoot and increased bridge deck clearance for better passage through the water
- Hulls designed asymmetrically to reduce interference drag
- Composite bow sprit
- Lower center of gravity

DID YOU KNOW?

- VPLP are world leaders in multi-hull yacht design, and the most highly qualified in the world when it comes to multihull racing boats. For the last 10 years VPLP has owned every record on all the oceans: round the world, transatlantic, 24 hours, etc. They have been the only French designers to collaborate in a winning America's Cup challenge and have won the last two Vendée Globe. Their mission: more comfort and volume without damaging performance.



Vincent Lauriot Prévost

KCB 3: MADE FOR SAILORS

Unprecedented storage capacity for all necessary equipment: outside, inside.

Each volume has been exploited to offer **a lot of storage space everywhere** on the boat.

Unique 3-cabin arrangement to further increase storage versatility.

KCB 3: A MODERN ATMOSPHERE

Maintain volume and good headroom, all this in a warm and as bright as ever interior design.

- An interior energized by plenty of natural light
- Interior woodwork in honey teak & white touch
- 360° view is everywhere through untinted windows: enjoy the sea, the sky and your sails!

KCB 4: WIDE AFT COCKPIT

- Super wide cockpit, combining liveable and practical layout.
- The ideal configuration, always connected with your boat and your guests, and never far from your steering stations
- Dining area, relaxing spaces and large storages.
- A very large aft beam settee with two table options: composite or teck extensions to meet both charter and owners expectations.

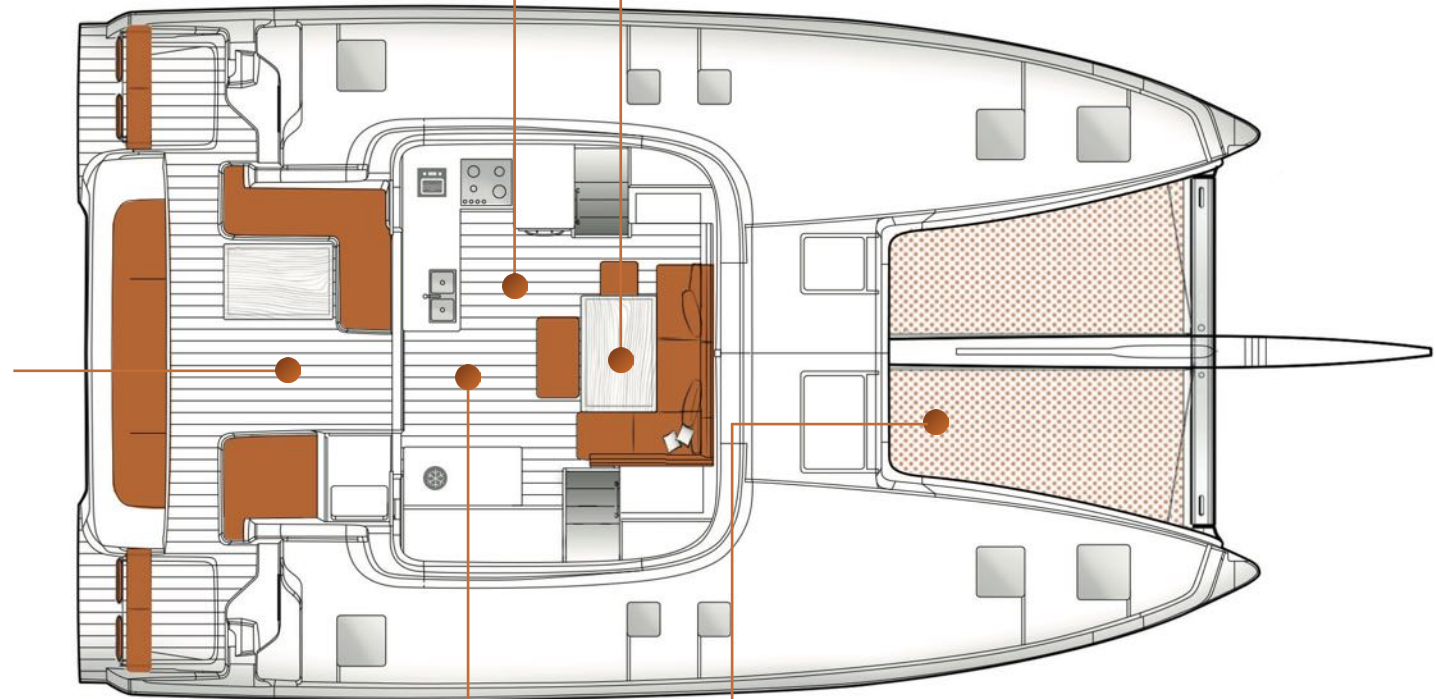

KCB 3: COMFORT AND MODULARITY OF LIVING SPACES

- A wide fully-equipped galley area, with a lot of storage
- A starboard corner that can be used as well for the galley as for the salon
- A retractable chart table integrated into the comfortable salon
- Dining area up to 8 pax
- Large refrigeration capacity with different solutions [up to 360L]
- Smart upper lockers to offer more and more storage space without obstructing visibility at helm stations
- Extra double berth in salon... per standard with the sofa upholstery!

KCB 3: A GREAT LIVING AREA

- A very **wide forward area**, via comfortable side decks
- Sailor first: large storage lockers with technical access & two full-size forepeaks
- Communication with the salon thanks to opening portholes in the glazing
- Easy and safe access to your skylounge or boom thanks to the comfortable coachroof access [option]
- Smart! A new forward cushions kit, for both trampoline and skylounge areas. Enjoying a special position between deck and trampoline, comfort and fun are utmost!

KCB 4: TO MEET ALL EXPECTATIONS

- Cabin provides brightness and a great view
- Many subdivided storage spaces: hanging closets, shelves, underneath the bed, etc. to maximize the living area
New! A standard hanging closet in the aft head for your wet clothes.
- Private head and separate shower in every configuration: 3C3H3S / 4C4H4S

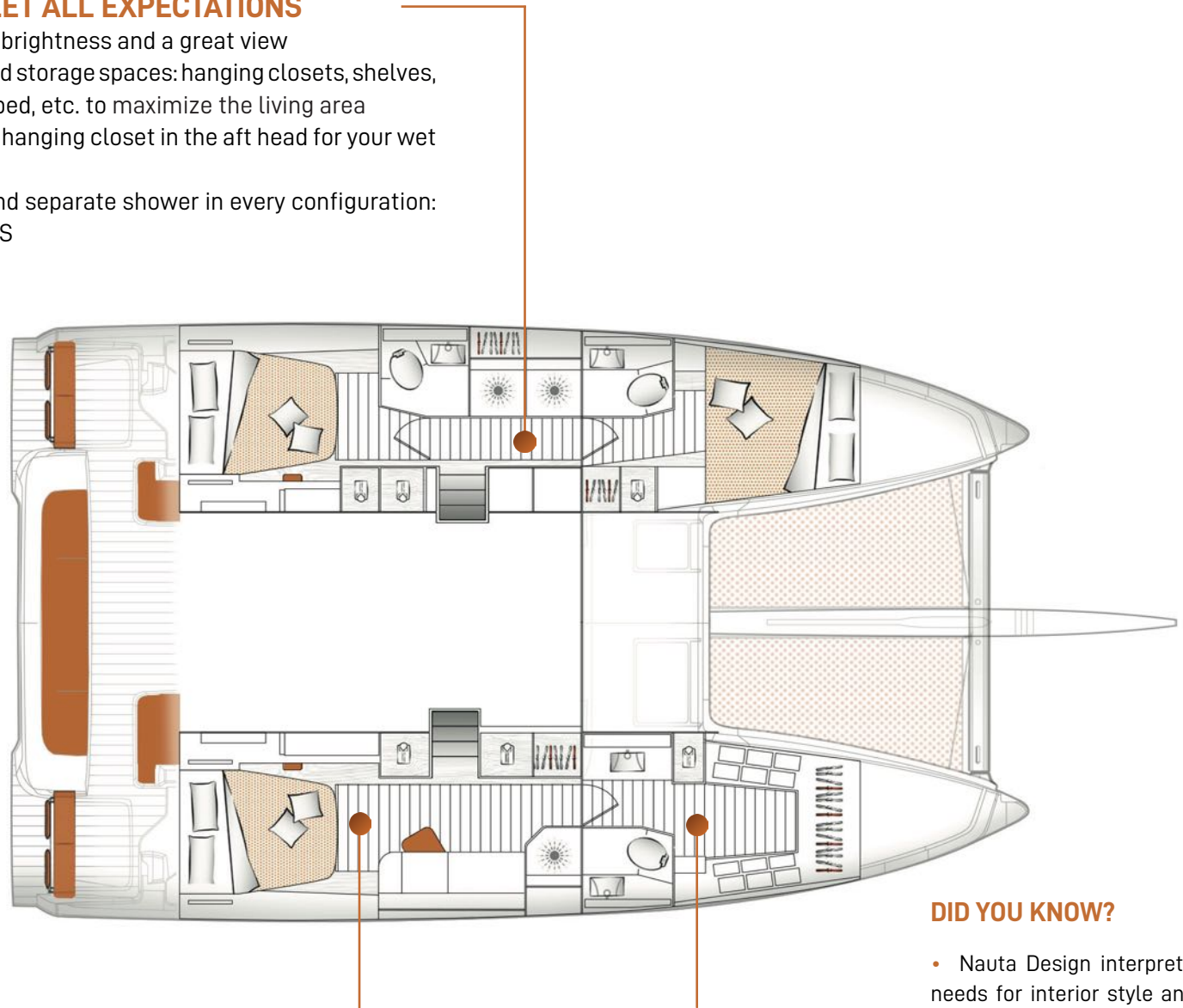

KCB 4: SAILOR'S SUITE

- "Full length" owner's suite with a new longitudinal volume distribution
- A large desk for work and storage, finally allowing you to live aboard your boat all year round!
- For setting off on your adventure, many storage spaces everywhere, including hanging closets
- Central bathroom with inboard and outboard vanity sinks.

KCB 4: FOR SAILING AND SHARING

- The huge walk-in dressing area [standard] allows you to store both sailing gear and casual clothes, thanks to upper storages, full-height hanging wardrobe, boxes, etc.
- With additional convertible twin berths [option], the whole family can enjoy the suite!

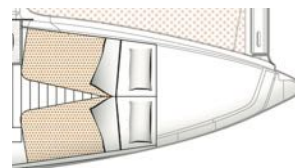

DID YOU KNOW?

- Nauta Design interprets owners' needs for interior style and exterior lines and turns them into projects of all types and sizes with elegance and simplicity. Nauta yachts are custom spaces, comfortable and efficient. Ideal yachts onboard which one can truly enjoy friends and family in privacy and a positive relationship with the sea and the surrounding environment in comfort and safety. Their mission: exceed client's expectations.



Massimo Gino - Mario Pedol

03





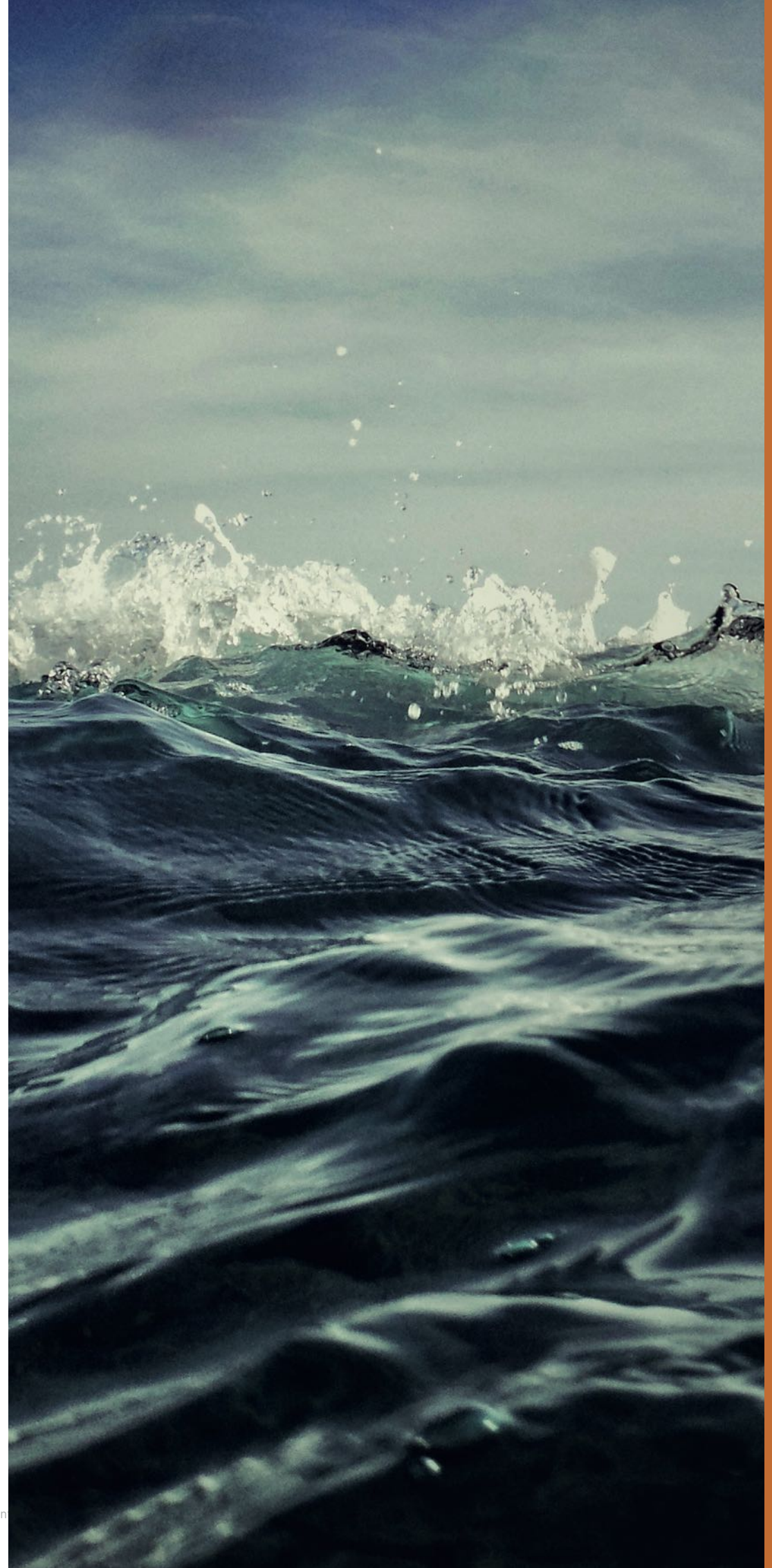

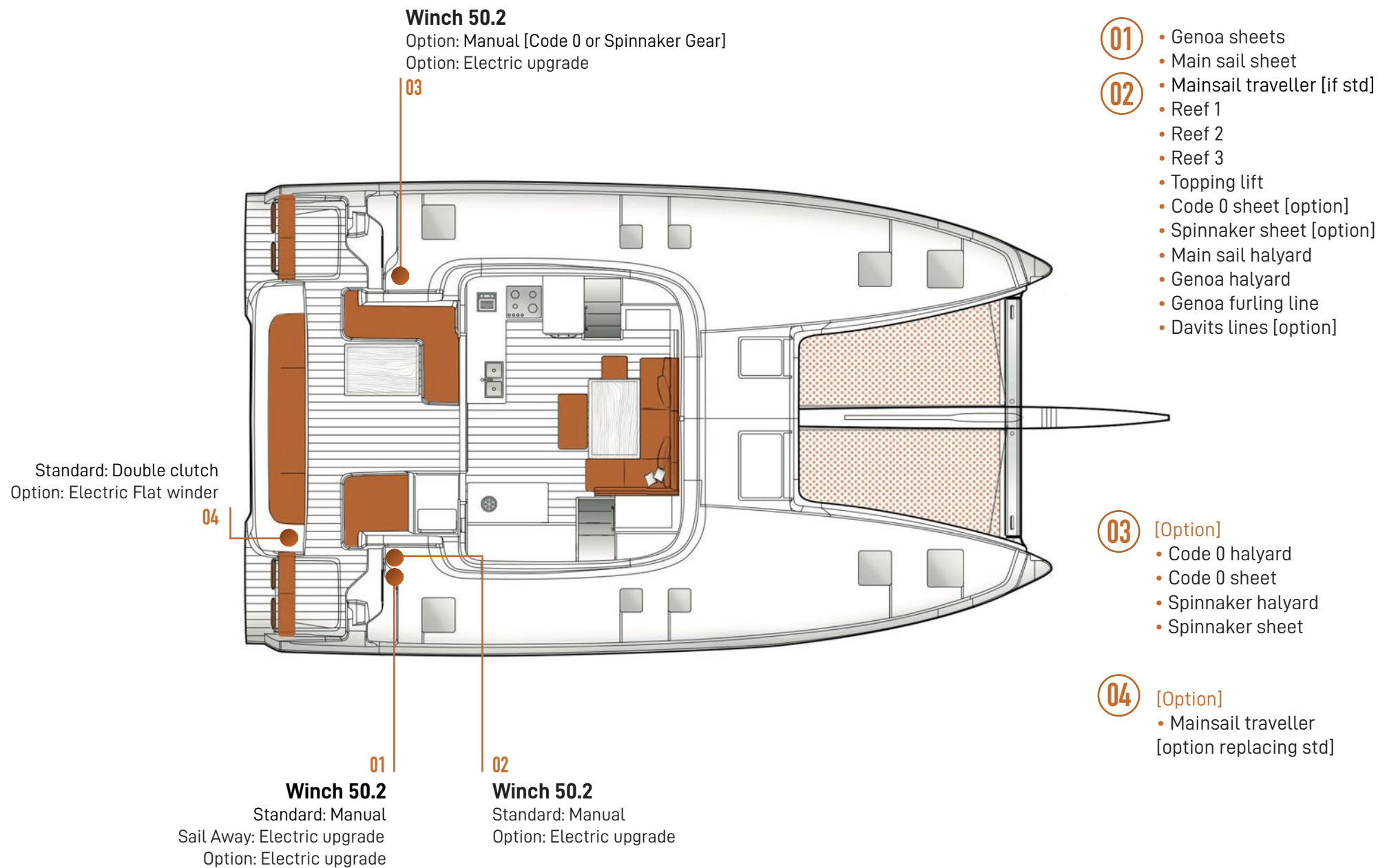

SAILING EXPERIENCE

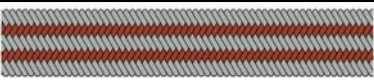
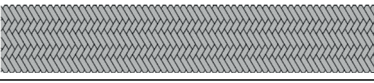
1. Helm stations
2. Deck fittings
3. PULSE LINE
4. Performance and velocity



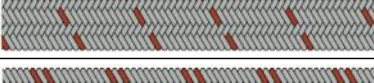









MAINSAIL

2:1 purchase mainsail halyard	ø10	65,00	Lancelin Punch	1	
Topping lift	ø10	47,00	Lancelin Callisto	1	
Mainsail sheet	ø10	45,00	Lancelin Callisto	1	
Mainsail line driver	ø10	7,20	Lancelin Punch	1	
Mainsail traveller Port	ø8	21,00	Lancelin Callisto	1	
Mainsail traveller Stbd	ø8	17,50	Lancelin Callisto	1	
Reef 1	ø12	29,00	Lancelin Callisto	1	
Reef 2	ø12	40,00	Lancelin Callisto	1	
Reef 3	ø12	38,00	Lancelin Callisto	1	
Barber hauler purchase			Lancelin Callisto	1	

GENOA

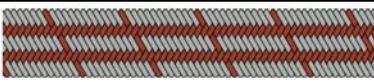
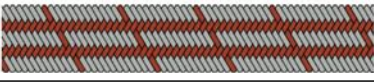
Genoa halyard	ø12	44,00	Lancelin Punch	1	
Genoa sheet Port	ø12	17,00	Lancelin Callisto	1	
Genoa sheet Stbd	ø12	13,00	Lancelin Callisto	1	
Genoa furling line			Lancelin Callisto	1	

CODE 0 / ASYM SPI

Spi halyard	ø12	52,00	Lancelin Punch	1	
2:1 purchase Code 0 halyard	ø10	70,00	Lancelin Punch	1	
Code 0/Spi sheets (Port&Stbd)	ø12	29,00	Lancelin Callisto	2	
Code 0 tack line	ø10	6,00	Lancelin Punch	1	
Spi tack line	ø10	8,00	Lancelin Punch	1	
Sous-barbe	ø6	2,90	Lancelin Callisto	2	

OVERLAPPING GENOA: A TRUE SAILING ASSET FOR YOUR BOAT!

Excess 14 comes with an overlapping genoa.

Combined with the mast positioned forward of the coachroof, this arrangement enables to :

- Reduce structural weight
- Reduce rig weight, for a given sail area
- Improve sailplan efficiency, especially in waves
- Allow precise trimming of the genoa twist
- Improve foresail geometry when partially furled
- Reduce mast height, hence pitching moment, for a given sail area
- Simplify running rigging circuits, reducing frictions.

Those benefits really add to the sailing sensations of the Excess 14!



NEXT PART SOON TO COME

04

OUTSIDE EXPERIENCE

1. Aft cockpit
2. Forward area
3. Roof
4. Tailored sailing equipment



SOON TO COME

05

INSIDE EXPERIENCE

1. Salon
2. Galley
3. Cabins

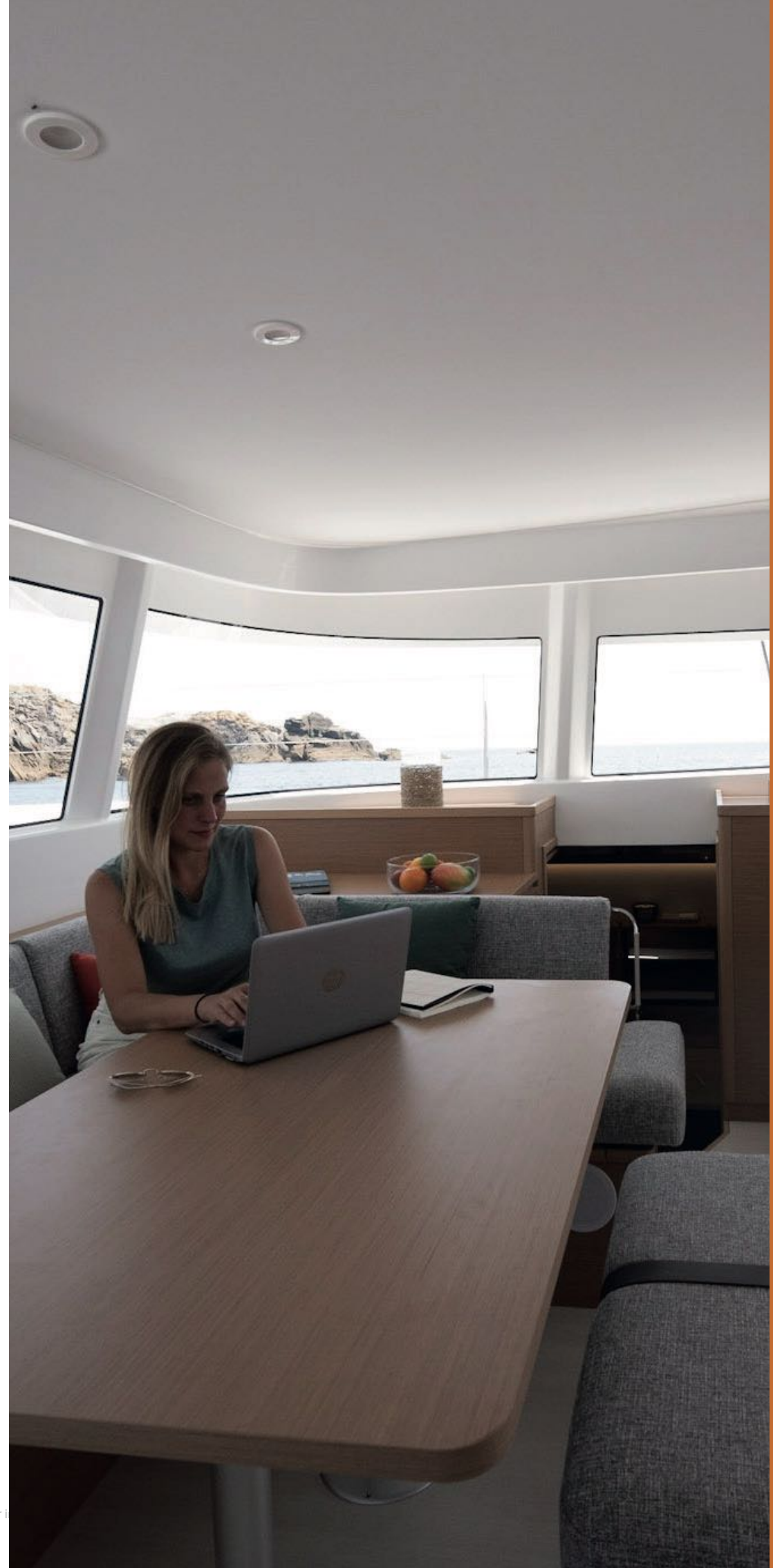

SOON TO COME



02

OPTIONS

01 SAIL AWAY PACK

02 SAILING EXPERIENCE

03 OUTSIDE EXPERIENCE

04 INSIDE EXPERIENCE

05 TECHNICAL EQUIPMENT

This chapter contains all the essential information you'll need to talk about options available on EXCESS 14 price list. Some standard equipment details are included.

01

SAIL AWAY

ELECTRIC PACK

GARMIN ELECTRONICS PACK

Portative compass

External USB outlet at starboard helmstation

Electric primary winch

Dimmer for cockpit and salon lighting

Upper starboard galley storage

Starboard double helm seat

Aft porthole in aft cabins with curtain

Lateral porthole in galley

Opening portholes x2 on forward roof

1 - Four additional service batteries 95A



Service battery bank

STANDARD	SAIL AWAY	TOTAL
2 x 95A [AGM]	+ 4 x 95A [AGM]	6 x 95 = 570A [AGM]

Location onboard underneath the bed [aft portside]

2 - 40A charger



40A battery charger | CRISTEC
Charges service batteries and engine

STANDARD	SAIL AWAY	TOTAL
PREFITTING	40A	1 x 40A
		1 x PREFITTING 40A

Location on port engine compartment.

3 - Battery controller



Power supply, charge level, lifespan.

A dedicated extra sensor allow to monitor the batteries lifespan and alert for replacing.

Information available on touch screen at chart table.

4 - Shore Power 32A

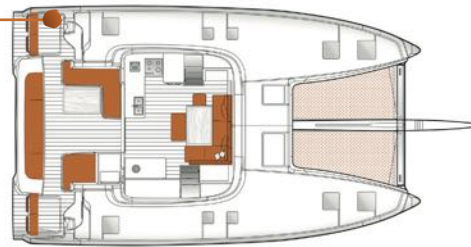

5 - [230V outlet + double USB sockets] in cabins & 230V outlet / USB sockets in salon



[110V sockets on the picture]

GARMIN ELECTRONICS PACK

01

SAIL AWAY

GARMIN®

1 - Wind transducer



Aerial gWind wired 010-0227-00 + communication unit

2 - Speed-Depth-Temp Transducer



Sensor DST810

3 - Autopilot



9-axis pilot compass
Pilot computer (Reactor 40)
LS40 pilot ram
Helm sensor GRF10

4 - Equipment at starboard helm station

GM120*



Tridata 4" GM120 multifunctional display

GHC50*



5" GHC50 autopilot display

DID YOU KNOW?

*Screens directly integrated in the deck.
No console per standard.

Compass



Compass 221154

External USB outlet



Starboard helm station

ELECTRIC PRIMARY WINCH

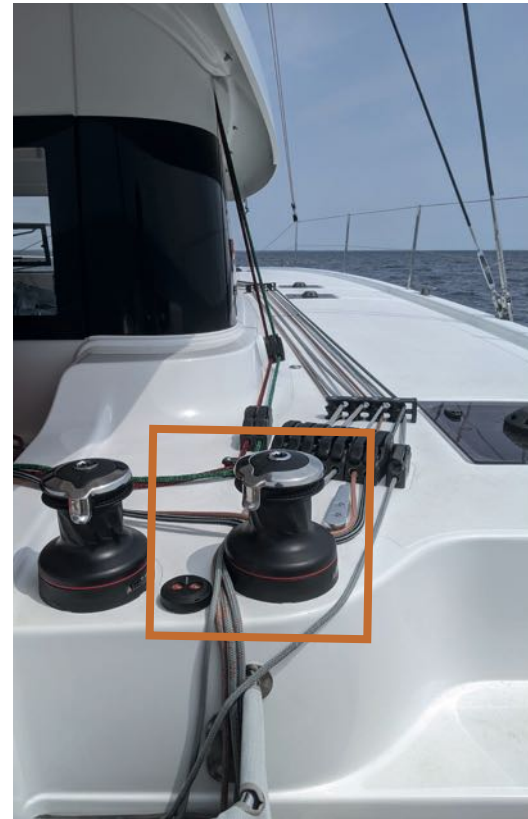

Electric upgrade from manual winch [per standard] on **starboard**.

Brand: HARKEN®
Model: 50.2 STEA

DIMMER FOR COCKPIT AND SALON LIGHTING

01
SAIL AWAY



Location on the port galley low-unit.

Press and hold the switch to activate the dimmer and adjust the light intensity.

UPPER STARBOARD GALLEY STORAGE

01
SAIL AWAY



New opening and closing system. Locker located behind the door.

Dimensions : approx. 900 L x 400 W mm | 2'11" x 1'4"

STARBOARD DOUBLE HELM SEAT

01 SAIL AWAY



Double foldable seat on starboard helm station
New design: one-piece composite seat.

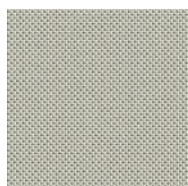

Color: Grey
FERRARI® Batyline Lounge Quartz
7720FR-50932

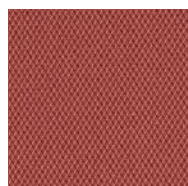

Color: Orange
SUNBRELLA® Mezzo Tigerlily
MEZZ 10222 140

AFT PORTHOLE IN AFT CABINS WITH CURTAIN

01
SAIL AWAY



[Starboard]



[Port]

x1 **Opening porthole** per aft cabin, with curtains.

LEWMAR - Mitre

Dimensions : 630 L x 170 W mm | 2'1" x 0'7"

LATERAL PORTHOLE IN GALLEY

01
SAIL AWAY



x1 **Opening porthole** located on galley to port only.

LEWMAR - Mitre
Dimensions: 480 x 340 mm | 17" x 11"

OPENING PORTHOLES X2 ON FORWARD ROOF

01
SAIL AWAY



x2 **Opening portholes** on central forward roof windows.

LEWMAR - Mitre

Dimensions : Approx. 660 L x 340 W mm | 2'2" x 1'1"

02

SAILING EXPERIENCE

RIGGING AND SAILS

PULSE LINE [Pack]

Code 0 Gear - For standard with bowsprit

Code 0 Gear - With long grey bowsprit

Asymmetrical spinnaker gear

Flat Winder for mainsail traveller

Electric primary Winch

Second starboard electric winch

Port electric winch

Code 0 in Mylar - Standard / Pulse Line

Lazy bag

ELECTRONICS

GPSMAP 12" at Starboard helm station

GPSMAP 12" at Port helm station

16" Display at Starboard helm station

16" Display at Port helm station

Fantom Radar 18"

Reactor autopilot remote controller

VHF single handset

AIS 800 transceiver

SAILING EXPERIENCE

RIGGING AND SAILS

02

PULSE LINE

THE CHOICE OF BOLD SAILORS SEEKING SENSATIONS!

The PULSE LINE is undoubtedly an exciting feature from design point of view to sailing experience! You can sail faster, enjoy sporty sail trimming and a definitively eye-catching design.



The PULSE LINE pack includes the following options:

- 1- PULSE LINE **Rigging & Sails plan**
- 2- **Mainsail barber hauler**
- 3- **Ball-bearing** trimmable genoa **cars**
- 4- **Square top mainsail and overlapping genoa** in [eXPR - EKKO](#) [Color: grey]
- 5- **Textile** lifelines
- 7- PULSE LINE **hull decoration**
- 6- PULSE LINE composite **steering wheels** [Color: Orange]

DID YOU KNOW?

Code 0 gear and long bowsprit is a separated option from the Pulse Line pack onboard Excess 14.

SAILING EXPERIENCE

RIGGING AND SAILS

02

PULSE LINE

1 - Rigging & Sail plan

With PULSE LINE, the mast configuration [Std: 19.78 m | 64'11" ; Pulse: 21.54 m | 70'8"] offers a great sails plan with a **larger**:

- Mainsail
- Overlapping genoa
- Code 0 [The option is NOT included in this pack]



 PULSE LINE Main Sail and Genoa

PULSE LINE increases SA/DSPL 4.81%, moving the ratio to a great 5.01. On the water there will be regularly a significant positive difference.



	STANDARD	PULSE LINE	%
Mast length	19.78 m 64'11"	21.54 m 70'8"	+ 8.9 %
Square top mainsail	83 m ² 893 sq ft	90 m ² 968 sq ft	+ 8.43 %
Overlapping genoa	40 m ² 430 sq ft	45 m ² 484 sq ft	+ 12.5 %
Upwind sail area	123 m ² 1,323 sq ft	135 m ² 1,453 sq ft	+ 9.76 %
Code 0 [if option selected]	72 m ² 775 sq ft	86 m ² 925 sq ft	+ 17.8 %
Sail Area / Displacement	4.78	5.01	+ 4.81 %

2 - Mainsail Barber Hauler

A flying barber hauler is a 4:1 hoist [same principle as the hoist of a dinghy catamaran] designed to be used with the mainsail sheet when the boat sails downwind, when the leeward mainsheet hoist lets go the boom to a point where the boom starts to move as much up as out: the leech of the main opens up and will very soon end up against the leeward rig shroud

To avoid this loss of power and this risk of damaging the sail cloth the flying barber hauler comes in: its top part is to connect to the top loop of the leeward mainsheet below the boom, the bottom is to connect on a padeye on the leeward side of the sheer line

Once in place, one trims the leech of the mainsail with both this device and the leeward mainsheet hoist. It can also be used as a boom preventer when sailing long downwind tacks.

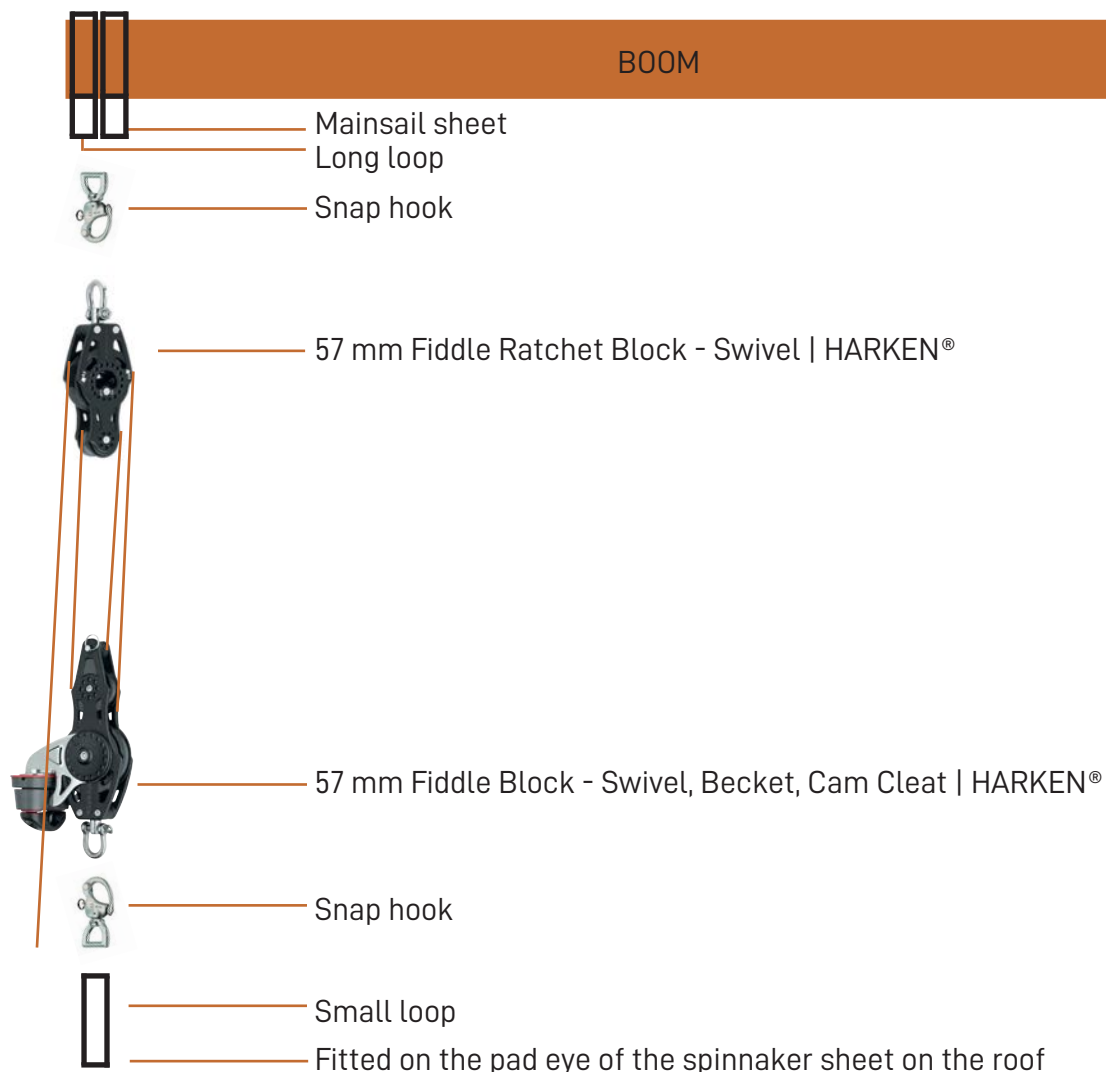

SAILING EXPERIENCE

RIGGING AND SAILS

02

PULSE LINE



[Photos on EXCESS 11]

You can cleat it to the aft mooring cleats, on starboard if you are on a port tack, or on port if on a starboard tack. You will balance the tension on the flying barber-hauler and the leeward mainsheet to get a proper shape.

Do not forget to remove it before jibing or tacking!

3 - Ball-bearing trimmable genoa cars



As Excess 14 as an overlapping genoa, PULSE LINE pack integrates ball-bearing trimmable genoa cars, making your maneuvers very easy.

Standard : genoa cars with pistons.

4 - Square top mainsail and overlapping

The boat comes in standard with a square top mainsail using top quality white Dacron®, with horizontal cut.

With the PULSE LINE we offer a high-end laminate with film, taffeta and fibers, made of recycled polyester. Together with a tri-radial assembly, it gives those larger sails better stiffness, less aging risks and lower impact on the planet.

Sails come in grey color.



[PULSE LINE]

eXRP EKKO
Tri-radial cut
Color: grey

[non-contractual color]



[STANDARD]

Dacron®
Horizontal cut
Color: white

[non-contractual color]



5 - Textile lifelines

The textile lifelines replace the stainless steel standard lifelines.

Made from fiber for more efficiency, the customized Lancelin lifelines are **fluorescent at night for safer night cruising.**

OPTION



1

Brand: Lancelin
Material: Fiber
Color: Grey & orange

2

The pad-eye is part of the option.
By selecting the textile lifelines
you get also a pad-eye.

6 - PULSE LINE hull decoration genoa in

We've created a distinction between the standard line and the sportier PULSE LINE, while maintaining the same spirit. The inspiration came from the logo, a sporty and elegant wake, fluid and dynamic, taken up in an immoderate way in its PULSE LINE version. Isabelle's interest in typography made the process almost natural. The combined lines at the back of the hulls highlight the turn of the bilges in a marked and legible manner.



HULL DECORATION BY ISABELLE KELLER



"I have sailed a lot, racing, with a crew and I have shared the life of a professional sailor for a long time. I have experienced ocean racing and great adventures like the Transats and the Vendée Globe, from the inside. And then, on a simpler level, I have always wanted to live by the sea, overlooking the Atlantic Ocean." Isabelle Keller, designer of the hull decoration.

7 - PULSE LINE steering wheels



OPTION



This option replaces the standard s/s steering wheels

Upgrade for both helm stations.

Brand; CARBONAUTICA

Material: Composite

Color: Orange

[Carbonautica - Steering wheel](#)

STANDARD



Material: Stainless steel & leather

Color: Dark grey

[Photo onboard EXCESS 12]

CODE 0 GEAR FOR STANDARD WHITE BOWSPRIT



Code 0 gear is an independent option, separate from Pulse Line pack on board Excess 14.

You can keep the standard bowsprit, either with standard or Pulse Line rig.

The option includes:

- Manual winch on portside + handle
- Port ropes bag
- Code 0 sheets & halyard rig

The short bowsprit is included per standard:

Length: 560 mm | 1'10"

Material: Composite

Color: White

Code 0 sail and furler are not included.

You can select the "CODE 0 IN MYLAR + FURLER [Standard sail plan and bowsprit]" option.

Then code 0 will be 72 m² | 775 sq ft.

[Incompatible ASYMMETRICAL SPINNAKER GEAR]

CODE 0 GEAR WITH LONG GREY BOWSPRIT



Code 0 gear is an independent option, separate from Pulse Line pack on board Excess 14. You can select the long bowsprit, either with standard or Pulse Line rig.

Code 0 sail is not included. You can select the "CODE 0 IN MYLAR [PULSE LINE sail plan and Long bowsprit]" option. Then code 0 will be 86 m² | 925 sq ft

[Incompatible ASYMMETRICAL SPINNAKER GEAR]

CODE 0 GEAR WITH LONG GREY BOWSPRIT



This option includes the following elements:

- A. Code 0 sheets**
 - Port Code 0 sheet
 - Starboard Code 0 sheet
 - 2 sheets blocks with swivel – Harken® Element Block Ø80 [Port and Starboard]

- B. Code 0 halyard**
 - Code 0 halyard
 - Mast foot block - Harken® Element Block Ø80
 - Mast head block - Facnor® opening halyard purchase block
 - 2 deck blocks - Harken® Element Block Ø80 [Port]
 - 2 jammers [bowsprit / halyard] - Spinlock® [Port]
 - 2:1 purchase tack line

- C. Winch on portside**
 - Manual winch - Harken® [STA 50.2]
 - Port ropes bag
 - Winch handle

- D. Long bowsprit**
 - Length: 1560 mm (+ 1 m | 3'3" vs standard) | 5'1"
 - Material: Composite
 - Color: Grey (same RAL hull color)



[Incompatible CODE 0 GEAR]

This option includes the following elements:

A. Spinnaker sheets

- Port Spi sheet
- Starboard Spi sheet
- 2 sheets blocks with swivel – Harken®
Element Block Ø80 [Port and Starboard]

B. Spinnaker halyard

- Spi halyard
- Mast foot block - Harken®
Element Block Ø80 [Port]
- 2 deck blocks - Harken®
Element Block Ø80 [Port]
- 1 jammer [halyard] - Spinlock® [Port]

C. Winch on portside

- Manual winch - Harken® [STA 50.2]
- Port ropes bag
- Winch handle

FLAT WINDER FOR MAINSAIL TRAVELLER

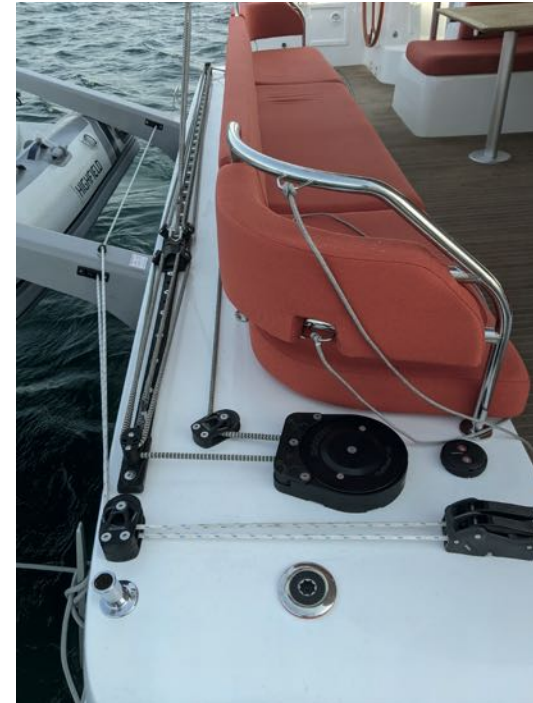

Electric flat winder on aft starboard.

Quantity: 1

Brand: HARKEN®

Model: FlatWinder

DID YOU KNOW?

Per standard, Excess 14 is equipped with two clutches, and the lines are lead towards the primary winch.

This self-contained electrically powered system is easy to use and offers sailors huge benefits in mainsail control, giving you the means to quickly depower the rig, and delay reefing when the wind picks up.

It operates in both directions allowing the car to move anywhere on the track while also keeping the traveler line off the cockpit floor.

Two Digital System Switches, one button to port, the other to starboard, are installed for activation from both sides of the boat.



Electric upgrade from manual winch [per standard] on **starboard**.

Brand: HARKEN®

Model: 50.2 STEA

[Included in Sail Away Pack]

SECOND STARBOARD ELECTRIC WINCH



Electric upgrade from manual winch [per standard] on **starboard**.

Brand: HARKEN®
Model: 50.2 STEA



Electric upgrade from manual winch [per standard] on **portside**.

Brand: HARKEN®

Model: 50.2 STEA

[CODE 0 GEAR or ASYMMETRICAL SPINNAKER GEAR option mandatory]

SAILING EXPERIENCE

RIGGING AND SAILS

AVAILABLE FOR **STANDARD SAIL PLAN** AND **PULSE LINE SAIL PLAN**

02

CODE 0 IN MYLAR



CODE 0 surface

Standard: 72 m² | 775 sq ft

PULSE LINE: 86 m² | 925 sq ft

This option includes :

- The Mylar laminate sail
- Code 0 furler



SAILING EXPERIENCE

RIGGING AND SAILS

02

LAZY BAG



Color: Charcoal grey
Sunbrella® SUNTT 5049 152

DID YOU KNOW?

Same lazy bag in Standard and Pulse Line sail plans.

GPSMAP 12" AT STARBOARD HELM STATION

GARMIN®

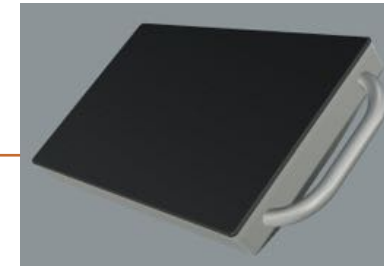
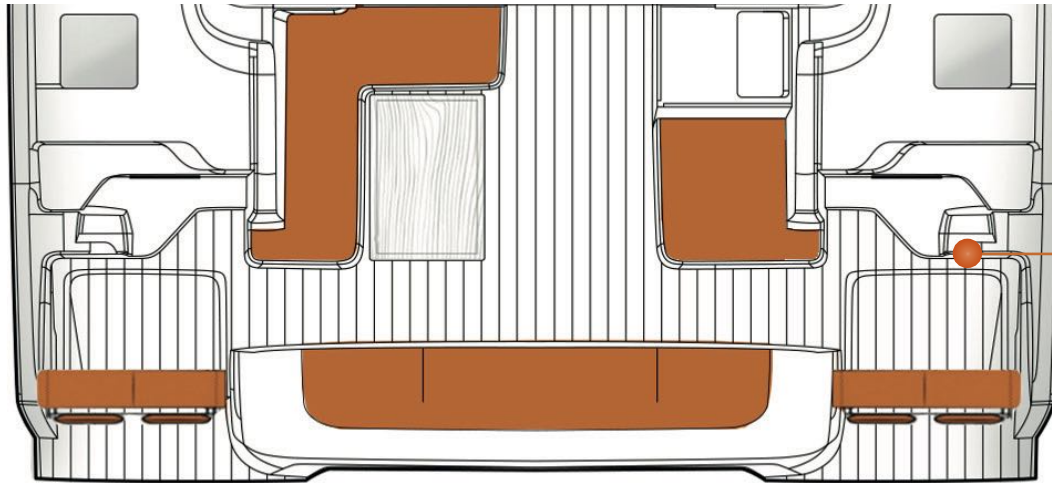

Composite helm station



12" GPSMAP
Model: 1223
Brand: Garmin



Brand: ROKK
Model: Mini universal tablet kit

PORT HELM STATION
CHART TABLE

This option includes :

STARBOARD [Helm station]:

- Composite console
- GPSMAP 12" multifonction display [Replaces GMI20 & GHC50 screens on deck]
- Worldwide cartography, available on all screens onboard
- 2 supports [port helm station & chart table] + 1 removable pedestal for tablet



[16" GPSMAP model on the pictures]

SAILING EXPERIENCE

ELECTRONICS

02

GPSMAP 12" AT PORT HELM STATION

GARMIN®

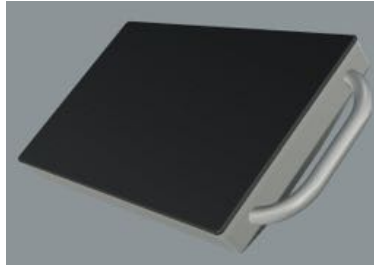

Composite helm station



12" GPSMAP
Model: 1223
Brand: Garmin

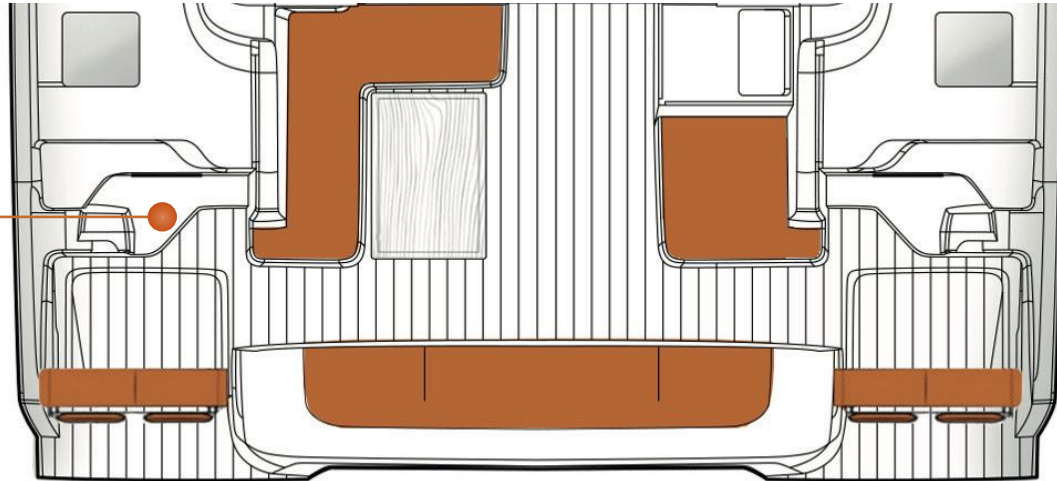

This option includes :

PORTSIDE [Helm station]:

- Composite console [replaces portside tablet support]
- GPSMAP 12" multifonction display

[Requires GPSMAP 12" at Starboard helm station, or FLEET'UP Package]



[16" GPSMAP model on the pictures]

SAILING EXPERIENCE

ELECTRONICS

02

UPGRADE FOR 16" DISPLAY AT STARBOARD HELM STATION

GARMIN®

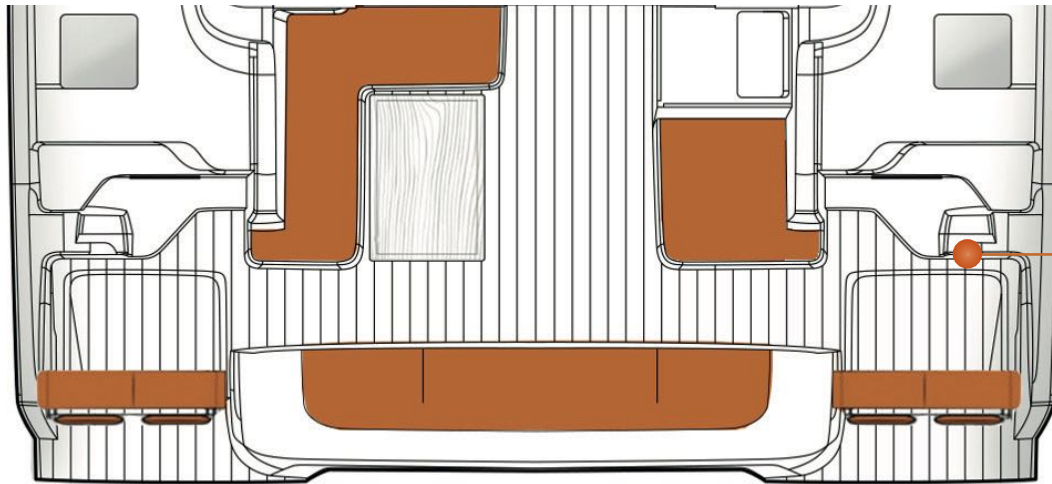

16" GPSMAP
Model: 8416
Brand: Garmin

This option includes :

STARBOARD [Helm station]:

- GPSMAP 16" multifonction display [Replaces 12" GPSMAP]

[Requires GPSMAP 12" at Starboard helm station]

This 16" screen is a real advantage. it allows a clear view of the information, both during the day and at night.
There is no equivalent on the market for a boat this size.



SAILING EXPERIENCE

ELECTRONICS

02

UPGRADE FOR 16" DISPLAY AT PORT HELM STATION

GARMIN®

16" GPSMAP
Model: 8416
Brand: Garmin

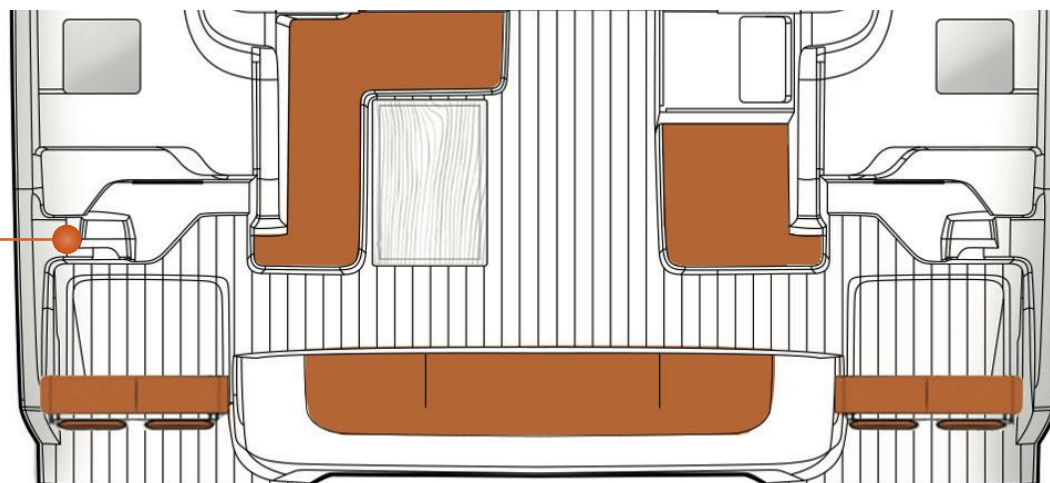
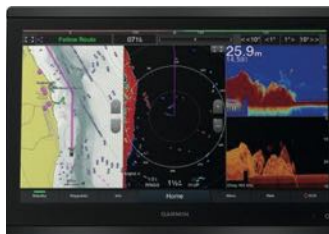

This option includes :

STARBOARD [Helm station]:

- GPSMAP 16" multifonction display [Replaces 12" GPSMAP]

[Requires GPSMAP 12" at Port helm station]

This 16" screen is a real advantage. it allows a clear view of the information, both during the day and at night.
There is no equivalent on the market for a boat this size.



SAILING EXPERIENCE

ELECTRONICS

02

FANTOM RADAR 18"

GARMIN®



GARMIN Phantom Radar 18"

Key features:

- High power radar
- Motionscope technology (Doppler use)
- Power save mode
- Timed emission mode (set up active and inactive periods)
- User-friendly operation

Location : first spreaders

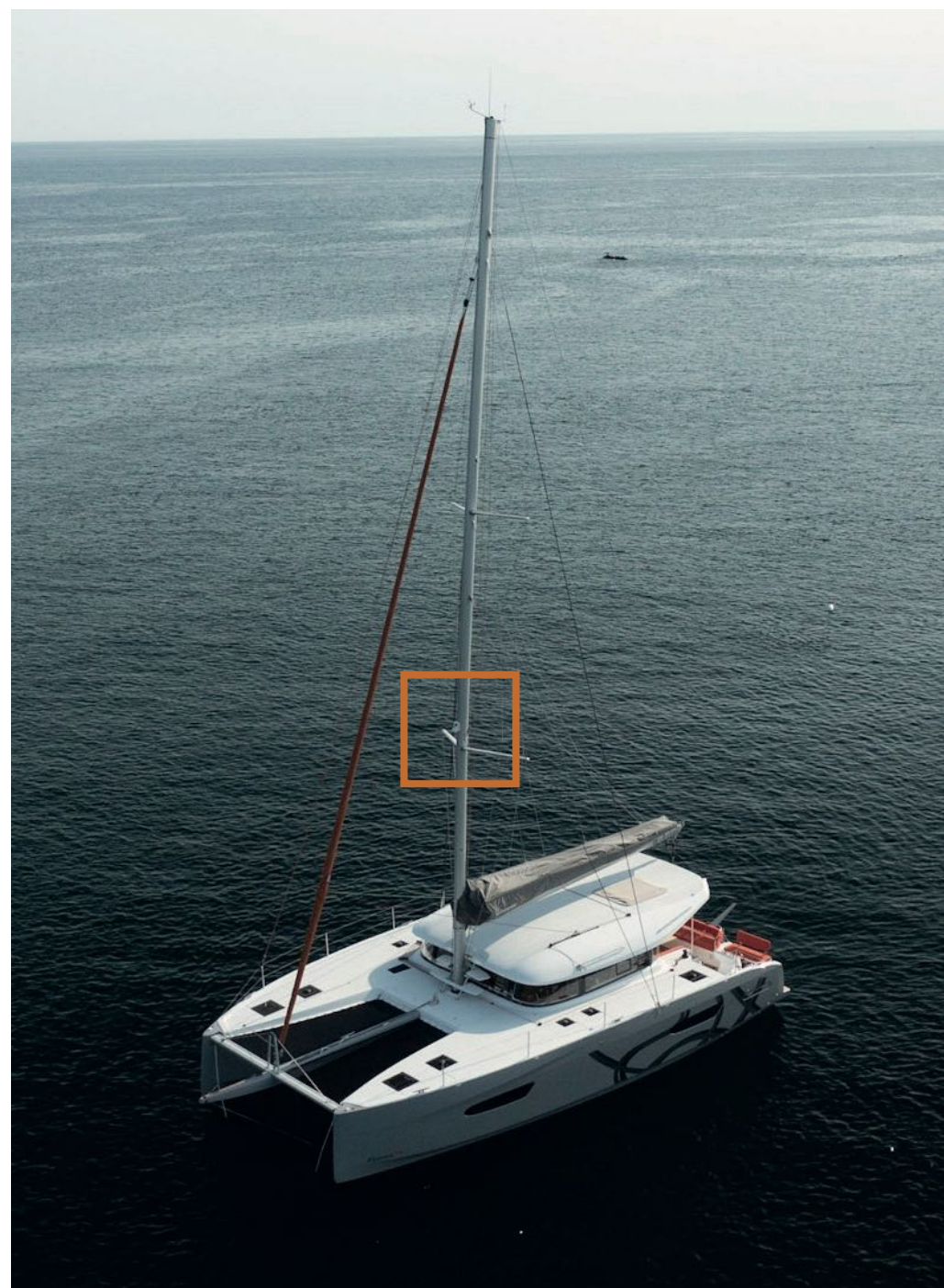

[This picture doesn't includes the option]

REACTOR AUTOPILOT REMOTE CONTROLLER

GARMIN®



Autopilot remote controller

Brand: GARMIN
Model : Reactor

Key features :

- Convenient, provides easy pilot mode and directional control for your Garmin autopilot
 - Gesture control mode, ensures easy operation. Point the remote in the direction you want to go to control the pilot
 - Bright color display that's easy to read even in bright sunlight.
- Ergonomically designed for easy viewing and control
- Programmable preset buttons provide quick access to your favorite functions
 - Waterproof and unsinkable, it floats even if you fall in the water

Location : chart table



VHF single handset

Brand: GARMIN
Model : VHF 315i

[Included in FLEET'UP Pack]

Key features:

- 25 W marine VHF with DSC class D function
- Includes GHS™ 11i handset and new active speakerphone that can serve as an intercom between 3 locations on the boat
- Integrated GPS receiver (requires external antenna)
- NMEA 2000® connectivity for easy integration with compatible plotters and multifunction displays
- Pre-programmed international marine channels

Location : chart table



AIS transceiver

Brand: GARMIN

Model : AIS 800

[Requires VHF] [Included in FLEET'UP Pack]

Key features :

- Reliable, easy-to-use communication system that transmits information about your boat to other nearby AIS receivers while receiving data from nearby AIS targets
- 5W Class B/S0 transmission power for faster-than-ever position reports
- Built-in GPS with connector for adding an optional external antenna
- NMEA 2000® connectivity for easy integration with compatible plotters and multifunction displays
- Built-in antenna splitter allows the VHF and AIS receiver to share the same antenna
- Translated with www.DeepL.com/Translator (free version)

Location : chart table

03

OUTSIDE EXPERIENCE

Skylounge with cushions [compatible with forward net], and access stairs

Coachroof access stairs

Windlass remote control at helm station with chain counter [Starboard]

Anchor kit [20kg anchor, 75m chain D10, 20m warp D18]

Pulpits with composite seats and forward lifelines

Exotic wood cockpit table with extensions + cover [Color: Cadet Grey]

Cockpit fridge 75L | 20 US Gal [12V]

Folding carbon gangplank with cover [2 sockets]

Composite davits

Dinghy pack CL340 with Honda engine 15HP

Outboard engine bracket

OUTSIDE UPHOLSTERIES

Enclosures with windows for aft cockpit [Color: Cadet Grey]

Biminis on port and starboard helm stations with windows [Color: Cadet Grey]

Starboard double helm station

Additional double helm seat [Portside]

Aft cockpit cushions

Aft cockpit sunbathing

Forward net / Skylounge cushions

Offering more versatility and enlarging your living areas onboard, the Skylounge is matching with both charter operators and private clients needs.

The area can't be used while sailing. The boom location while using the skylounge has been carefully designed to fully and easily enjoy the area at anchor.

This option includes :

SKYLOUNGE

The option includes the large composite skylounge moulding, integrated in the roof.

FRONT ACCESS

For a comfortable access, the option includes the large stairs in the forward cockpit.

This way, you can safely access the skylounge with drinks or any accessory.

This option requires:

CUSHIONS KIT* [* "Forward net / Skylounge cushions" option]

A complete new upholstery kit has been developed and can be fully stored in the skylounge, and protected by a flush cover.

Comfortable cushions with alongside sun pads, they are compatible with the forward net! 1 kit for 2 sunbathing areas: a true asset! You also save storage space.



These stairs offer a wide and safe access to the roof, both for relaxation and for lazy bag access. They are located in the forward area around the mast.

[Included in the Skylounge option]

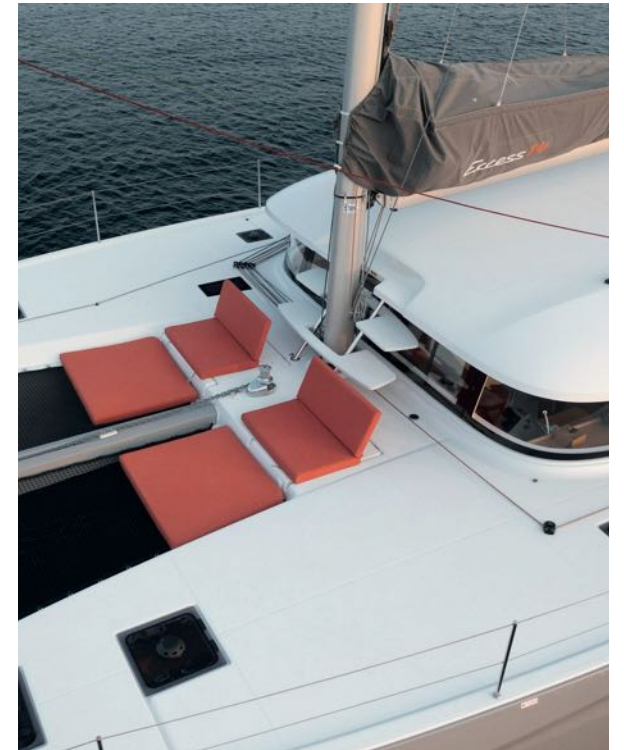

The option includes:

- Windlass remote control from starboard helm station
- A chain counter

The option completes standard QUICK remote control in the chain locker.

Brand: QUICK

Model: QNC CHC

Location: Starboard helm station



This option includes :

- 20kg anchor
- 75m chain D10
- 20m warp D18



PULPITS WITH COMPOSITE SEATS AND FORWARD LIFELINES



[Picture onboard Excess 15]

This option includes:

- 2 forward pulpits [port and starboard] with composite seats
- Lifelines between pulpits and crossbeam A-bracket

The option is available with **stainless steel or textile** lifelines.

EXOTIC WOOD COCKPIT TABLE WITH EXTENSION



The exotic wood cockpit table replaces the standard composite table.

The option includes:

- A table top made of exotic wood
- A removable cockpit table extension
- A protective cover



Color: Cadet Grey
Sunbrella® SUNTT 5530 152

The extended table allow you to use the aft beam seat to enjoy a large outside dining area.

Dimensions [Table+extension]: Approx. 1690 L mm x 730 W mm | 5'7" x 2'5"

[Incompatible composite cockpit table extension]



[Table extension]



[Exotic wood table without extension]

COMPOSITE COCKPIT TABLE EXTENSION



[Composite standard table onboard Excess 11 - without extension]



The composite cockpit table extension fits the standard composite table.
 The table's full composite top is easy to clean and maintain.
 The extended table allows you to use the aft beam seat to enjoy a large outside dining area.
 Meets both charter and owner's expectations.

Dimensions [standard table]: Approx. 1300 L mm x 790 W mm | 4'3" x 2'7"

Dimensions [standard table+extension]: Approx. 1710 L mm x 790 W mm | 5'7" x 2'7"

[Incompatible exotic wood cockpit table]

[Included in Fleet'up Pack]

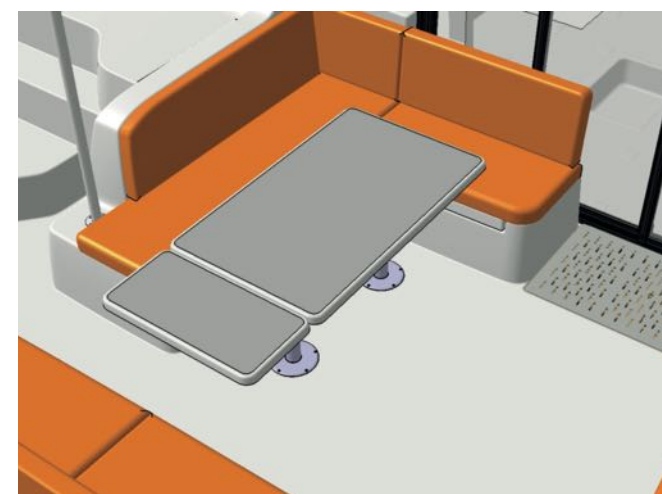

[Composite table with extension]



12V refrigerator located in the aft starboard cockpit.

75 L | 20 US Gal

Replaces the storage unit per standard.

Brand: Vitrifrigo

Model: DW70

Color: s/s

[Included Fleet'Up Pack]



With the platform positioned very far aft, the Excess 14 takes full benefit of the folding gangplank.

The option includes :

- Gangplank
- Cover
- 2 Sockets

Gangplank dimensions

Open: 2,600 x 350 mm | 8'6" x 1'1"

Closed: 1,300 x 350 mm | 4'3" x 1'1"

New onboard Excess 14 : davits are made of composite and not of stainless steel as for the rest of the range.

Composite davits support the same weight and length capacity for your dinghy. They are designed for the recommended dinghy pack [CL310 Highfield + 15HP engine]. They are lightweight and offer a great design.

The option includes:

- A pair of composite davits
- Complete lifting hardware and lines

Max dynamic load per davit: 150 kg | 331 lbs



Use one of your winches to easily lift your dinghy.



Brand: HIGHFIELD
Model: CL310
Engine: Honda 15HP
Pax: 5



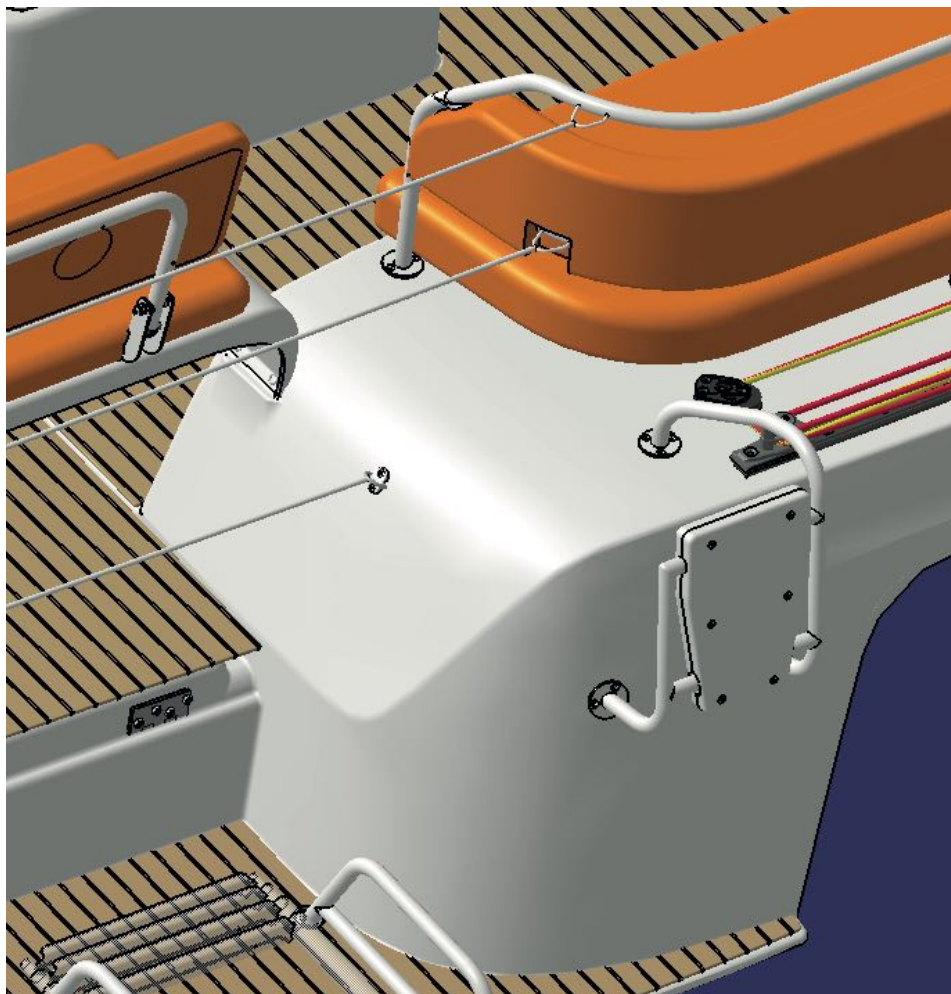

Stainless steel fixed bracket for dinghy outboard engine.
Location: to port, on the aft beam.

LOCATION ON BOARD

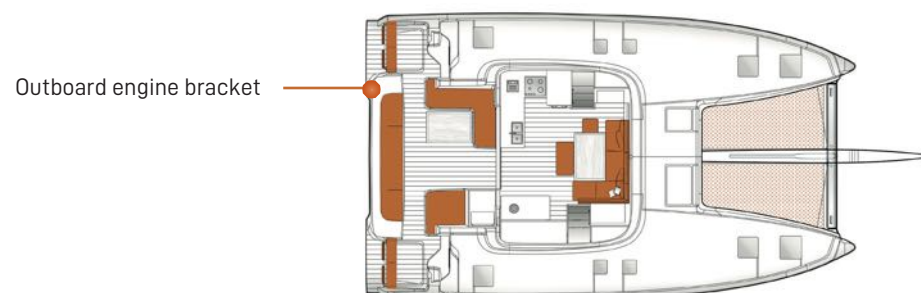

ENCLOSURES WITH WINDOWS FOR AFT COCKPIT

Ideal to extend life time on board during mid-season.

Protecting your boat and yourself from bad weather, this option includes:

- 1 large enclosure for aft cockpit
- 2 enclosures with 2 doors on portside and starboard

Made in fabric with PVC transparent windows.



Color: Cadet Grey
Sunbrella® SUNTT 5530 152

BIMINIS ON HELM STATIONS



Protect yourself from the sun and spray, while enjoying steering sensations!

This option includes :

- **2 biminis** with removable enclosures and windshield [on **portside and starboard helm stations**]
- Stainless steel structure with canvas top roof
- Dedicated storage bag for each bimini enclosure



Color: Cadet Grey
Sunbrella® SUNTT 5530 152

STARBOARD DOUBLE HELM SEAT



Double foldable seat on starboard helm station.
New design: one-piece composite seat.

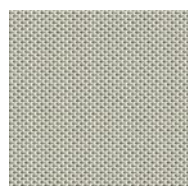

Color: Grey
FERRARI® Batyline Lounge Quartz
7720FR-50932

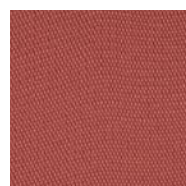

Color: Orange
SUNBRELLA® Mezzo Tigerlily
MEZZ 10222 140

ADDITIONAL DOUBLE HELM SEAT [PORTSIDE]



Double foldable seat on port helm station.

New design: one-piece composite seat.

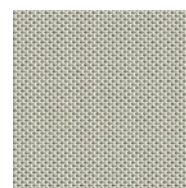

Color: Grey
FERRARI® Batyline Lounge Quartz
7720FR-50932



Color: Orange
SUNBRELLA® Mezzo Tigerlily
MEZZ 10222 140



The option includes cushions - and upholstery color - for all aft cockpit settees :

- L-shaped sofa on portside
- Starboard daybed
- Aft beam settee

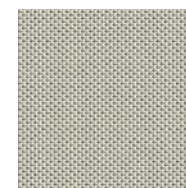

Color: Grey
FERRARI® Batyline Lounge Quartz
7720FR-50932



Color: Orange
SUNBRELLA® Mezzo Tigerlily
MEZZ 10222 140



[Pictures onboard Excess 15]



Aft bench and modular table transforming into a wide sunpad area.

The option includes:

- 2 table pedestals
- 2 mattresses

Option compatible with wooden and composite cockpit tables.

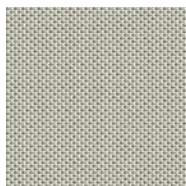

Color: Grey
FERRARI® Batyline Lounge Quartz
7720FR-50932

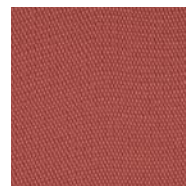

Color: Orange
SUNBRELLA® Mezzo Tigerlily
MEZZ 10222 140

FORWARD NET / SKYLounge CUSHIONS



The "Forward net / skylounge cushions" is a kit of cushions, compatible for both areas. They include "seating" cushions with backrests and sunpads.

You can select this option with the skylounge, or stand-alone to enjoy it on the forward area.

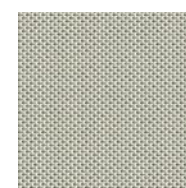

Color: Grey
 FERRARI® Batyline Lounge Quartz
 7720FR-50932

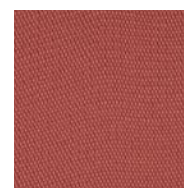

Color: Orange
 SUNBRELLA® Mezzo Tigerlily
 MEZZ 10222 140

04

INSIDE EXPERIENCE

Honey Teak & White lacquered wood

Valley floor

Inside Tailored Pack [Fast & Curious, Work Hard Play Hard, Less is More]

UPHOLSTERIES, CARPETS AND CURTAINS

PVC Interior Upholstery

Extra double settee in the salon

Additional stool

Carpet in the salon

Carpet in Owner's cabin

Curtains on salon door and windows

INTERIOR EQUIPMENT

Additional berths in the walk-in dressing

Upper starboard cabinet in galley

Berth in bow compartment

Opening hatch in the bow bulkhead

Adjustable wooden table in salon

Fans in salon and cabins

Additional fridge/freezer 155L | 41 US Gal in salon

Additional fridge 130L | 34 US Gal

Microwave Oven

KERROCK® solid countertop in galley

KERROCK® solid countertop in heads

Pre-fitting for washer/dryer in starboard companionway

Slatten berths

Reverse cycle air conditioning

Lateral porthole in galley

HI-FI

TV Antenna

Pre-fitting for LED TV in the owner's cabin

Pre-fitting for LED TV in the salon

FUSION Sound Pack in salon and cockpit

INSIDE EXPERIENCE

INTERIOR WOOD

04

HONEY TEAK & WHITE LACQUERED WOOD

For details, please refer to [Chapter 3: Chart Colors](#).

INSIDE EXPERIENCE

INTERIOR WOOD

04

VALLEY FLOOR

For details, please refer to [Chapter 3: Chart Colors](#).

INSIDE EXPERIENCE

INSIDE TAILORED PACKS

04

INSIDE TAILORED PACKS

For details, please refer to [Chapter 3: Chart Colors](#).

INSIDE EXPERIENCE

UPHOLSTERIES, CARPETS AND CURTAINS

04

PVC INTERIOR UPHOLSTERY

Interior upholstery in beige PVC, in salon sofa and settees onboard Excess 14.
Includes all settees in the salon and in the owner's cabin plus stool [3-cabin version]

Fabric changes: PVC upholstery

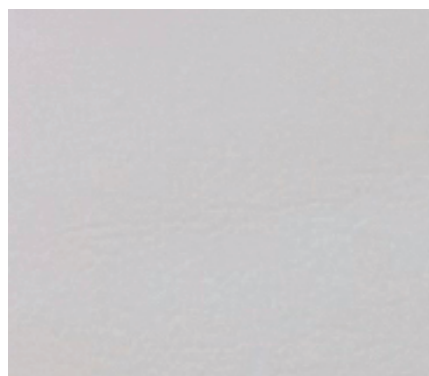

Color: Marlin Weiss
Spradling®

INSIDE EXPERIENCE

UPHOLSTERIES, CARPETS AND CURTAINS

04

EXTRA DOUBLE SETTEE IN THE SALON

STANDARD FOAM AND MANUFACTURING FINISHING

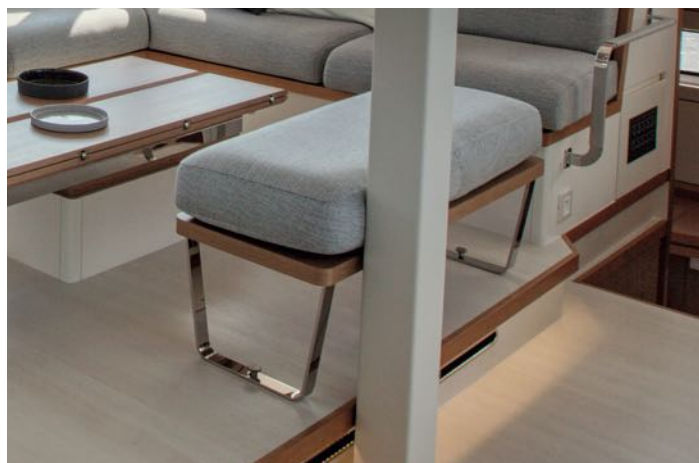

[Excess 15]

Dimensions: 890 H x 435 W mm | 2'11" x 1'5"
Thickness: 130 mm | 0'5"

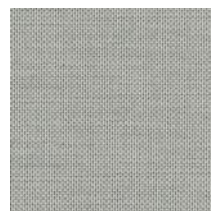

Color: Silver
Bru® Lounge Forte - 161 Silver



Color: Marlin Weiss
Spradling®

INSIDE TAILORED PACK [Included in Interior Tailored Pack]

Foam as per standard. Leather upgrade finishing.



[Excess 15]

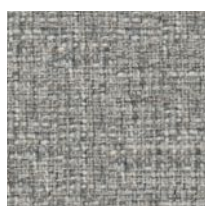

FAST AND CURIOUS
Color: Spartacus 21
Bru®



WORK HARD PLAY HARD
Color: Divine 45
Crevin®



LESS IS MORE
Color: Trailblazer 29
Bru®

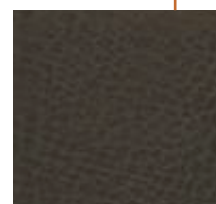

Leather strip upgrade finishing
Ultrafabrics® Ultra Leather
French Roast - 535-3231
[Same finishing for all tailored packs]

DID YOU KNOW?

One double settee is already included in the Inside Tailored packs onboard Excess 14.

INSIDE EXPERIENCE

UPHOLSTERIES, CARPETS AND CURTAINS

04

ADDITIONAL STOOL

A - STANDARD FOAM AND MANUFACTURING FINISHING

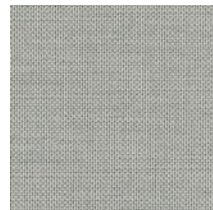

Color: Silver
Bru® Lounge Forte - 161 Silver

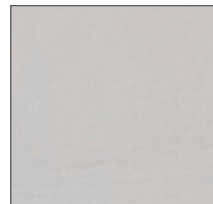

Color: Marlin Weiss
Spradling®

Stool made in foam covered with fabric.
Dimensions: 423 H x 437 W mm | 0'16" x 0'17"

B - **OPTIONAL** INSIDE TAILORED PACK

Foam as per standard. Leather upgrade finishing.



FAST AND CURIOUS
Color: Spartacus 21
Bru®

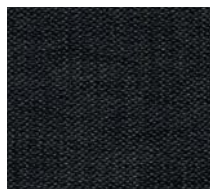

WORK HARD PLAY HARD
Color: Divine 45
Crevin®



LESS IS MORE
Color: Trailblazer 29
Bru®

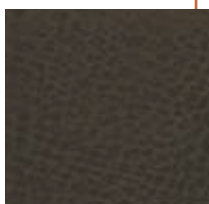

Leather upgrade finishing
Ultrafabrics® Ultra Leather
French Roast - 535-3231
[Same finishing for all tailored pack]

INSIDE EXPERIENCE

UPHOLSTERIES, CARPETS AND CURTAINS

04

CARPET IN THE SALON

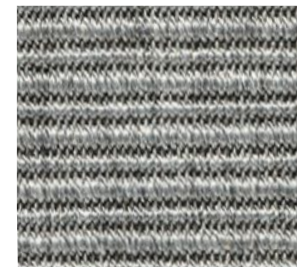

Color : Grey

[Picture onboard Excess 15]

This option includes **x1 carpet in salon**.
Dimensions: 1,690 L x 1,200 W mm | 5'7" x 3'11"

LOCATION ON BOARD

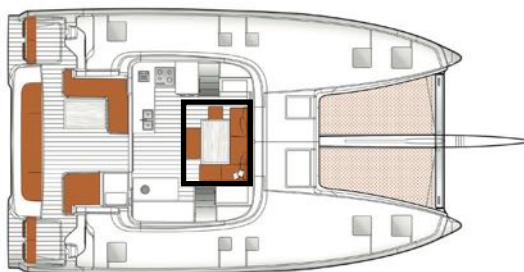

INSIDE EXPERIENCE

UPHOLSTERIES, CARPETS AND CURTAINS

04

CARPET IN THE OWNER'S CABIN



[Picture onboard Excess 15]

This option includes **x1 carpet in the Owner's cabin.**
Dimensions: 2,490 L x 860 W mm | 8'2" x 2'10"

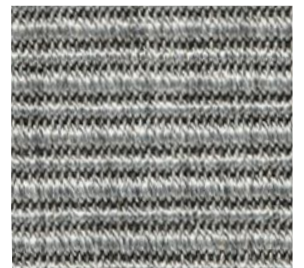

Color : Grey

LOCATION ON BOARD



INSIDE EXPERIENCE

UPHOLSTERIES, CARPETS AND CURTAINS

04

CURTAINS ON SALON DOOR AND WINDOWS

The option includes:

- Curtains on aft door to cockpit
- Curtains on all roof windows in salon

Same design as for Excess 11 & 12:



[Excess 11]



Color: Grey
SLEEP IN
Serenity-23-Whisper

ADDITIONAL BERTHS IN THE WALK-IN DRESSING

[Standard]



This option transforms your walk-in dressing into an additional and modular sleeping area.

You keep most of the capacity storage of the standard walk-in dressing.

[Option]



Option includes:

- 2 wooden boards
- 2 mattresses [approx. each 700 x 2000 mm | 2'4" x 6'7"]

The 2 wooden boards (mattresses included) can be folded and fixed along each board (in and out).

[3 cabin version only]

INSIDE EXPERIENCE

INTERIOR EQUIPMENT

04

UPPER STARBOARD GALLEY STORAGE



New opening and closing system. Locker located behind the door.

Dimensions : approx. 900 L x 400 W mm | 2'11" x 1'4"

The option is available on **portside and starboard**.

The option includes:

- Wooden storage with shelves
- An opening porthole with curtain

Brand: Lewmar

Dimensions: Approx. 350 L x 170 W mm | 1'2" x 0'7"

- Mattresses

Dimensions: Approx. 2,080 L x 1,350 W mm | 6'10" x 4'5"

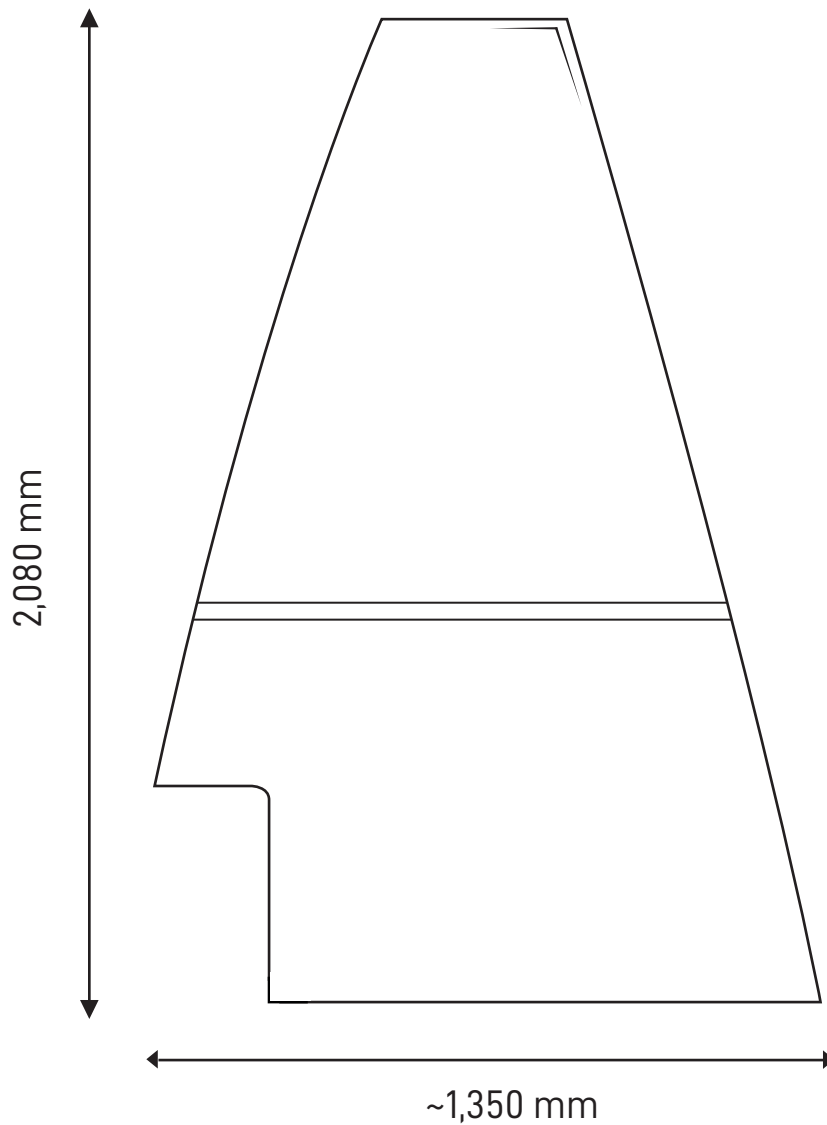

DID YOU KNOW?

- "Berths in bow compartments" and "Opening hatch in bow bulkheads" options are independent.

You can select the opening hatch on bulkhead without the bow compartment option. And vice versa.

INSIDE EXPERIENCE

INTERIOR EQUIPMENT

04

OPENING HATCH IN BOW BULKHEAD

The option is available on **portside and starboard**.

Per bow compartment:
x1 opening hatch in the bulkhead

Brand: Lewmar

Dimensions: 440 L x 440 W mm | 1'5" x 1'5"



[Sample picture - no contractual]

DID YOU KNOW?

- **"Berths in bow compartments" and "Opening hatch in bow bulkheads" options are independent.**

You can select the opening hatch on bulkhead without the bow compartment option. And vice versa.



[Picture onboard Excess 12]

Modular table similar to the one of Excess 12.
This is a convertible dining table into a coffee table.

The option includes :

- 1 manual aluminium table pedestal to low and raise the table
- folding table top

The table does not allow sleeping in the salon.

DID YOU KNOW?

The double berths in the salon is included per standard, with the standard table only.

How ?

- Backrests of the standard upholstery allow to create the double mattress
- 2 smaller aluminium table pedestals are included per standard

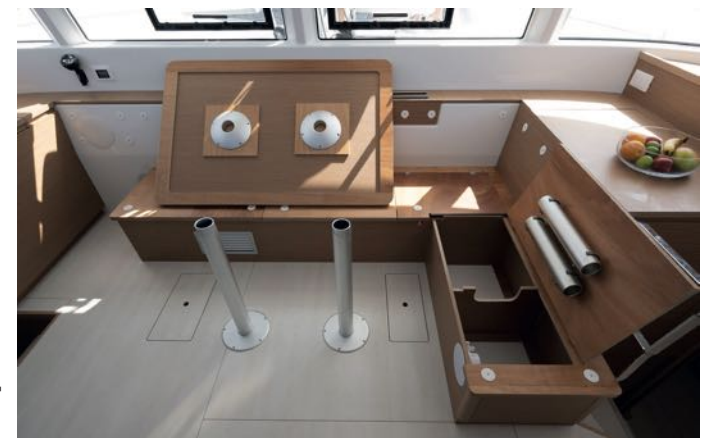

[standard]





Brand/Model: BORA
Color: White

The option includes:
- 1 Fan per cabin
- 2 Fans in Owner's suite
- 2 Fans in salon

[Included in Fleet'Up Pack]

ADDITIONAL FRIDGE/FREEZER 155L IN SALON



Fridge & Freezer 155L | 41 US Gal [12V] in starboard galley.
Double-drawer 90L Fridge / 65L Freezer [24/17 US gal].

Replaces the storage unit per standard.

Brand: Vitrifrigo
Model: DRW 180
Color: s/s

[Incompatible Fleet'Up Pack & Additional 130L Fridge]

[Standard]





[155L Fridge/freezer in the picture]

Fridge 130L | 34 US Gal [12V] in starboard galley.

Replaces the storage unit per standard.

Brand/Model: Webasto

Model: Cruise 130

Color: s/s

[Incompatible Additional 130L Fridge] [Included in Fleet'Up Pack]

[Standard]



Prefitting option only.

Available for 120 and 230V.

Microwave not included.



The option replaces the standard finish [2 different countertops per standard].

By choosing the option, you're **fully upgrading your galley countertop** with Kerrock®:

[Standard on **portside**]



Grigio Sasso | Laminate
Color: grey

[Standard on **starboard**]

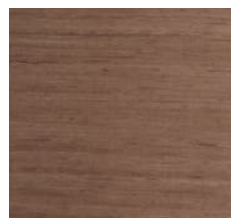

Honey Teak
Color: wood



Kerrock® galley countertops [**on port and starboard**]

[Option]

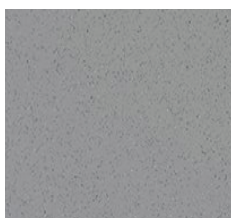

KERROCK®
Reference : Manganite 91 99
Color : grey

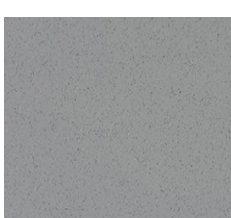

KERROCK®
Reference : Manganite 91 99
Color : grey

DID YOU KNOW?

- **Kerrock® is available only onboard Excess 14. Why Kerrock® ?**

Kerrock is lighter. You benefit from a 6mm countertop instead of 12mm, without any visual impact on the design.

AVAILABLE FOR 3 & 4 CABIN VERSIONS

This option replaces the standard finish [Compact - Laminate] in the heads, by a Kerrock countertop [Manganite 91 99].

[Standard]



Grigio Sasso | Laminate
Color: grey



Kerrock® heads countertop [in all heads]
[Option]

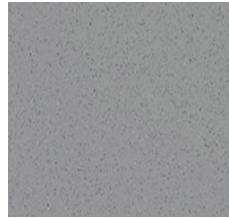

KERROCK®
Reference : Manganite 91 99
Color : grey



PRE-FITTING FOR WASHER / DRYER IN STARBOARD COMPANIONWAY



AVAILABLE FOR 3 & 4 CABIN VERSIONS

Prefitting option only.

Available for 120 and 230V.

Location: inboard closet in aft starboard cabin [4C-version] or Owner cabin [3C-version].

Wahser/dryer not included.

LOCATION ON BOARD

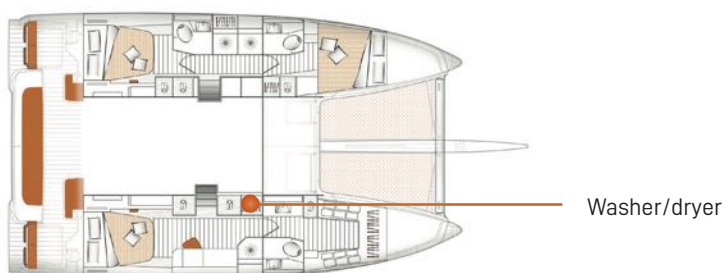

INSIDE EXPERIENCE

INTERIOR EQUIPMENT

04

SLATTED BERTHS

AVAILABLE FOR 3 & 4 CABIN VERSIONS

The slats allow a better ventilation of the mattress, and offer a better comfort.
Adapted to the charter as to the owners.

The option doesn't change mattresses.
Upgrades your forward and aft cabins.

INSIDE EXPERIENCE

INTERIOR EQUIPMENT

04

REVERSE AIR CONDITIONING

AVAILABLE FOR 3 & 4 CABIN VERSIONS [230V | 110V]

Seawater-cooled AC unit: Heat is transferred from the cabin air to the refrigerant gas to the seawater.

Reverse cycle on heating mode.

1 x control device per cabin

1 x control devices in the salon [located next to the chart table]

Please note, the control device is an "on/off". No possibility to choose the temperature.

Blowing grids



Additional AC shore power



Control device [salon]

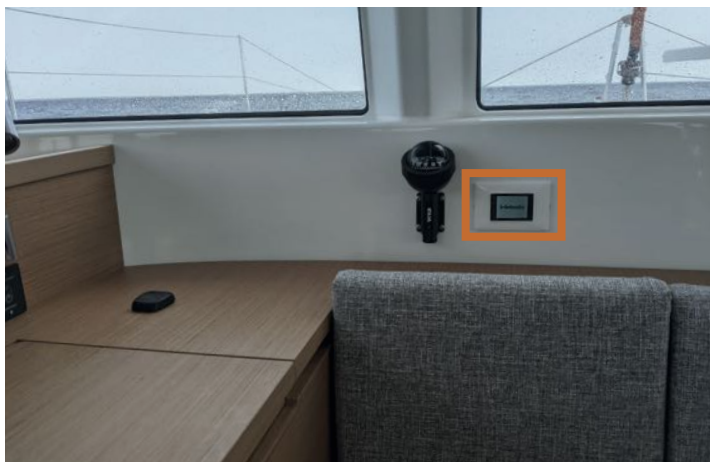

Control device [cabin]



AC unit



The boat is designed for:

3 and 4-cabin Versions: 36 000 BTU

- Salon: 1x 16 000 BTU
- Hulls: 1x 10 000 BTU

Electrical specification:

230V version: additional 1 x 32 A shore power included in the option

110V version:

- SAIL AWAY shore power is replaced by a 50A shore power
- An additional 50A shore power is added on board

To use the air conditioning: do not forget to connect on the shore power or to the generator.

[Requires GENERATOR PRE-FITTING]



x1 **Opening porthole** located on galley to port only.

LEWMAR - Mitre

Dimensions: 480 x 340 mm | 1'7" x 1'1"

[Included in SAIL AWAY Pack]

The option includes :

- TV antenna
- TV antenna amplifier
- TV cable pre-installed in roof to link amplifier and antenna

Prefitting option only.

Available for 120 and 230V.

TV not included.



Location : in front of the bed, on the inboard bulkhead.

INSIDE EXPERIENCE

HI-FI

04

PRE-FITTING FOR LED TV IN THE SALON

Prefitting option only.

Available for 120 and 230V.

TV not included.



Location : aft starboard of the salon to avoid obstructing visibility from the helm station.

INSIDE EXPERIENCE

HI-FI

04

FUSION SOUND PACK IN SALON AND COCKPIT

NEW: FUSION® sound pack

- FUSION® stereo unit [Apollo MS-RA670]
- USB socket x1
- Loudspeakers x2 in the salon [FM-F65RW]
- Loudspeakers x2 in the aft cockpit [FM-F65RW]



Stereo unit

Brand: FUSION®
Model: Apollo MS-RA670
Color: Black

Sources:
RADIO / WiFi / Bluetooth / AUX

Control:
From the front panel
From the navigation screens

From the FUSION® app

Same audio source and volume in the salon and outside.



Loudspeaker

Brand: FUSION®
Model: FM-F65RW
Color: White



05

TECHNICAL EQUIPMENT

ENGINES

Engines 2x 57 HP

Twin electric engines throttles at helm stations

Pair of 3-blades folding propellers

ELECTRICAL CIRCUIT

Generator pre-installation

Lithium batteries 360A

Dimmer for cockpit and salon lighting

External USB outlet

Inverter 2kVA

Solar panels on davits

WATER CIRCUIT

Additional fresh water tank 300L|79 US Gal

Watermaker 100L/H | 26 US Gal/H

Sea water foot pump

Fresh water dock inlet

Deck wash pump [Sea water|Fresh water]

Sea water electrical toilets

TECHNICAL EQUIPMENT

ENGINES

05

ENGINES 2X 57 HP



The option includes the engine replacement from standard [Yanmar 4JH45 | 2 x 45HP] to [Yanmar 4JH57 | 2 x 57HP]

The optional Yanmar 4JH57 comes with 18" x 15 3-blades fixed propellers.

Standard: Excess 14 is equipped with Yanmar 4JH45 and 18" x 14 3-blades fixed propellers.

TECHNICAL EQUIPMENT

ENGINES

05

TWIN ELECTRIC ENGINES THROTTLES AT HELM STATIONS

Directly fitted on both helm stations [port and starboard], electric engines throttles replaces the standard mechanical throttle [1 on starboard main helm station].

This option includes :



On STARBOARD

- Engine throttles upgrade: electric in lieu of one mechanical in standard



On PORTSIDE

- Secondary electric engine throttles

DID YOU KNOW?

The option replaces both engine throttles but does not duplicate the engine panels. The **engine control panels remain only on the starboard helm station.**

This to simplify the use and be more reliable.

TECHNICAL EQUIPMENT

ENGINES

05

PAIR OF 3-BLADES FOLDING PROPELLERS

Replaces fixed propellers [standard].

Brand : FENWICK

Model : Flex-o-fold

Option available for both standard and optional engines:

- Foldable propeller [45HP] 17" x 14
- Foldable propeller [57HP] 18" x 14

TECHNICAL EQUIPMENT

ELECTRICAL CIRCUIT

05

GENERATOR PRE-INSTALLATION

Recommandation:

230V 50HZ: 7KVA

110V 60HZ: 9KVA

[Incompatible ADDITIONNAL FRESH WATER TANK] [Incompatible FLEET'UP PACK]



[Location on starboard technical compartment]

TECHNICAL EQUIPMENT

ELECTRICAL CIRCUIT

05

LITHIUM BATTERIES 360A

This option includes 4 lithium batteries [4 x 90 A]
Total: 360A.

Lithium batteries works with same charger as for AGM batteries.
Location onboard underneath the bed [aft portside].

The option replaces the standard service battery bank.
EXCESS 14 comes with 2 [std] +4 [Sail Away] x 95 A | AGM service batteries.

[Require SAIL AWAY or FLEET'UP PACK]

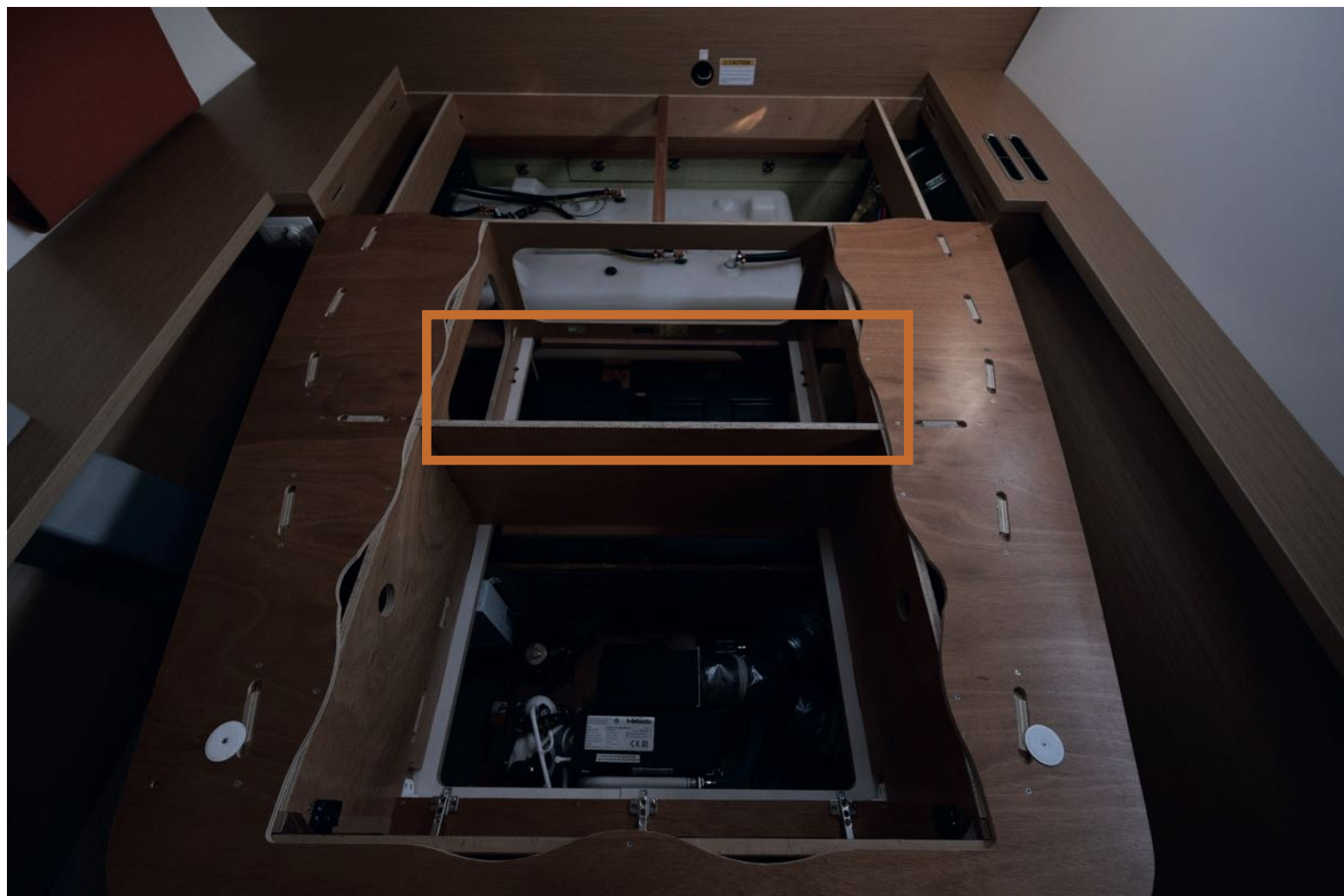

TECHNICAL EQUIPMENT

ELECTRICAL CIRCUIT

05

DIMMER FOR COCKPIT AND SALON LIGHTING



Location on the port galley low-unit.

Press and hold the switch to activate the dimmer and adjust the light intensity.

TECHNICAL EQUIPMENT

ELECTRICAL CIRCUIT

05

EXTERNAL USB OUTLET



This option includes x1 USB outlet at starboard helm station only.

[Included in SAIL AWAY Pack]

TECHNICAL EQUIPMENT

ELECTRICAL CIRCUIT

05

INVERTER 2KVA



Brand: MASTERVOLT
Model: AC Master 12|2000 [Ref: 28512000]
Power: 2,000 VA

Available in 230V and 110V.

Automatic selection when shore power is detected from the system
Power switches automatically from the inverter to the shore power.

TECHNICAL EQUIPMENT

ELECTRICAL CIRCUIT

05

SOLAR PANELS ON DAVITS

The option includes 4 panels of 130 W each [Total: 520 W]
Fixed support.

Brand : SOLARA

Quantity : 4

Rated output : 130W

Cell technology : mono crystalline with backcontact

[Requires COMPOSITE DAVITS]

Does not necessarily require lithium batteries.

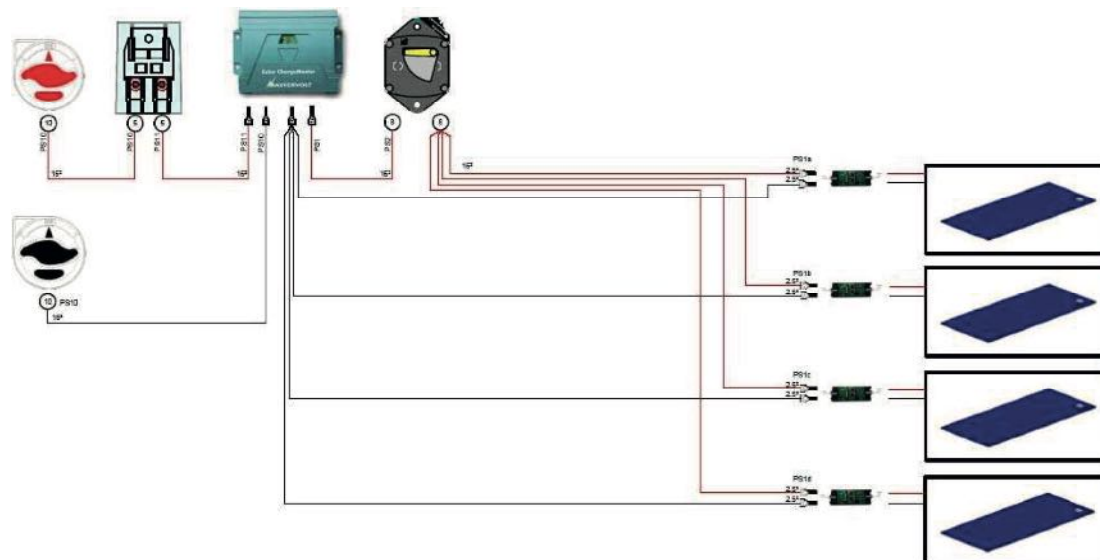

TECHNICAL EQUIPMENT

WATER CIRCUIT

05

ADDITIONAL FRESH WATER TANK 300L



An additional fresh water tank is available on starboard [300 L | 79 US gal].

- Capacity [option]: 300 L | 79 US gal
- Total capacity [standard + option]: 600 L | 158 US gal

[Incompatible GENERATOR PRE-INSTALLATION]



[Option location: starboard forward compartment] [Generator on the picture]



[standard]

LOCATION ON BOARD

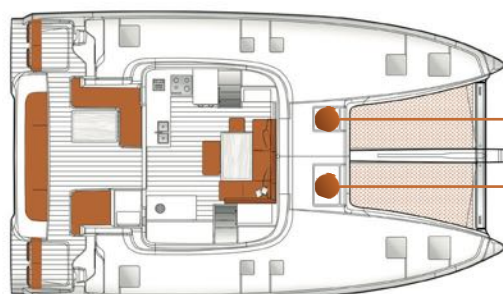

Fresh water tank: 300 L | 79 US gal [standard]

Fresh water tank: 300 L | 79 US gal [option]

TECHNICAL EQUIPMENT

WATER CIRCUIT

05

WATERMAKER 100L



Fresh water maker located underneath forward port cabin.
Access from the top.

Brand: DESSALATOR

Model: Dessal 100 L / H - 12/230V [26 US Gal]



Control panel also located on forward port cabin.

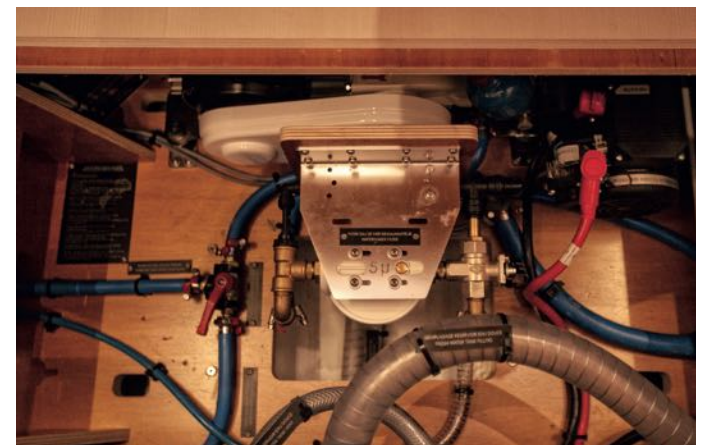

[Dessal 100L onboard Excess 15]

TECHNICAL EQUIPMENT

WATER CIRCUIT

05

SEA WATER FOOT PUMP

[standard on pictures]



Manual sea water foot pump located on port galley.
Option comes with dedicated tap.



[Excess 11 dedicated tap]



Manual pump

Brand: Whale

TECHNICAL EQUIPMENT

WATER CIRCUIT

05

FRESH WATER DOCK INLET



[Excess 15]



[Excess 14]

Located on aft starboard, fresh water pump connected to fresh water standard tank.

TECHNICAL EQUIPMENT

WATER CIRCUIT

05

DECK WASH PUMP

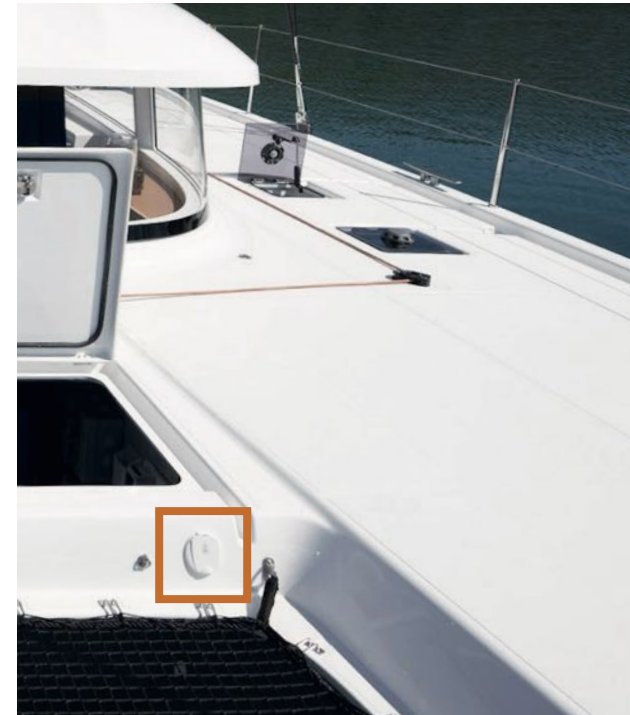

The manual valve and the outlet, are located in the port forward deck locker.
The valve allows the selection between sea water and fresh water.

Pump and valve accessible from port forward locker.

TECHNICAL EQUIPMENT

WATER CIRCUIT

05

SEA WATER ELECTRICAL TOILETS

This option is available for 3 & 4 cabin versions.
Replaces the standard manual toilets.



Brand: JABSCO
Model: Quiet Flush Electric Toilets 37045 Series



03

CHART COLORS

01 INTERIOR STANDARD

02 INTERIOR OPTIONS

03 INTERIOR TAILORED PACKS

04 EXTERIOR

This chapter contains all the essential information you will need to talk about the interior atmosphere. You'll find details about standard finitions, upgrades and options, and interior tailored packs.

WOOD
Honey teak



FLOOR
Sand



GALLEY COUNTERTOP
Laminate | Grigio Sasso



SOFA
Silver



STORAGE [folder on bulkhead]
Eden grey

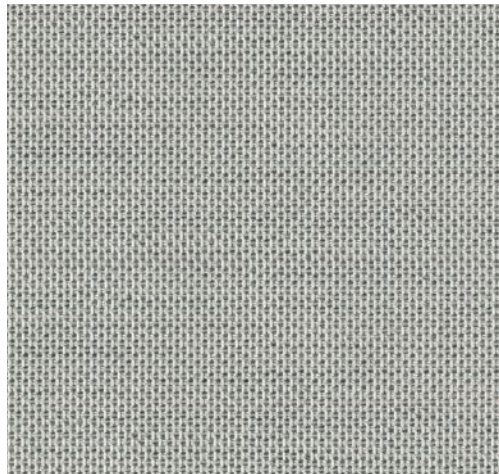

STORAGE [hanging storage]
Eden grey

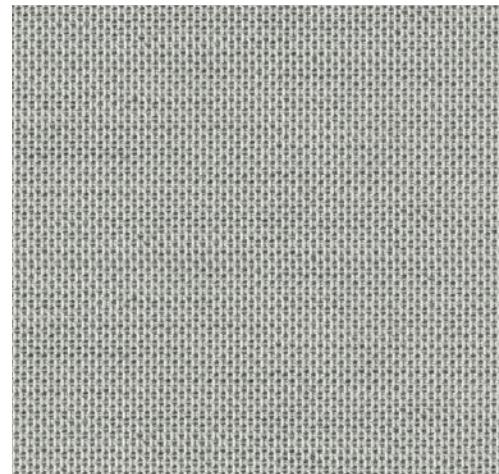

DID YOU KNOW?

- The "**hanging storage**" and "**folder on bulkhead storage**" are located in the cabins only.





STANDARD

Please note here Kerrock and Inside Tailored pack options are included.

①

WOOD
Honey teak



②

FLOOR
Sand

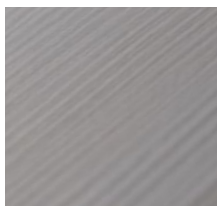

③

SOFA
Silver

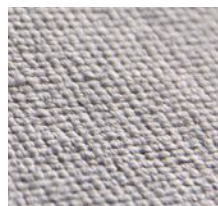

④

GALLEY COUNTERTOP
Laminate | Grigio Sasso

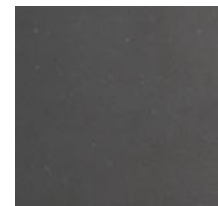

02

INTERIOR OPTIONS

1. Wood
2. Floor

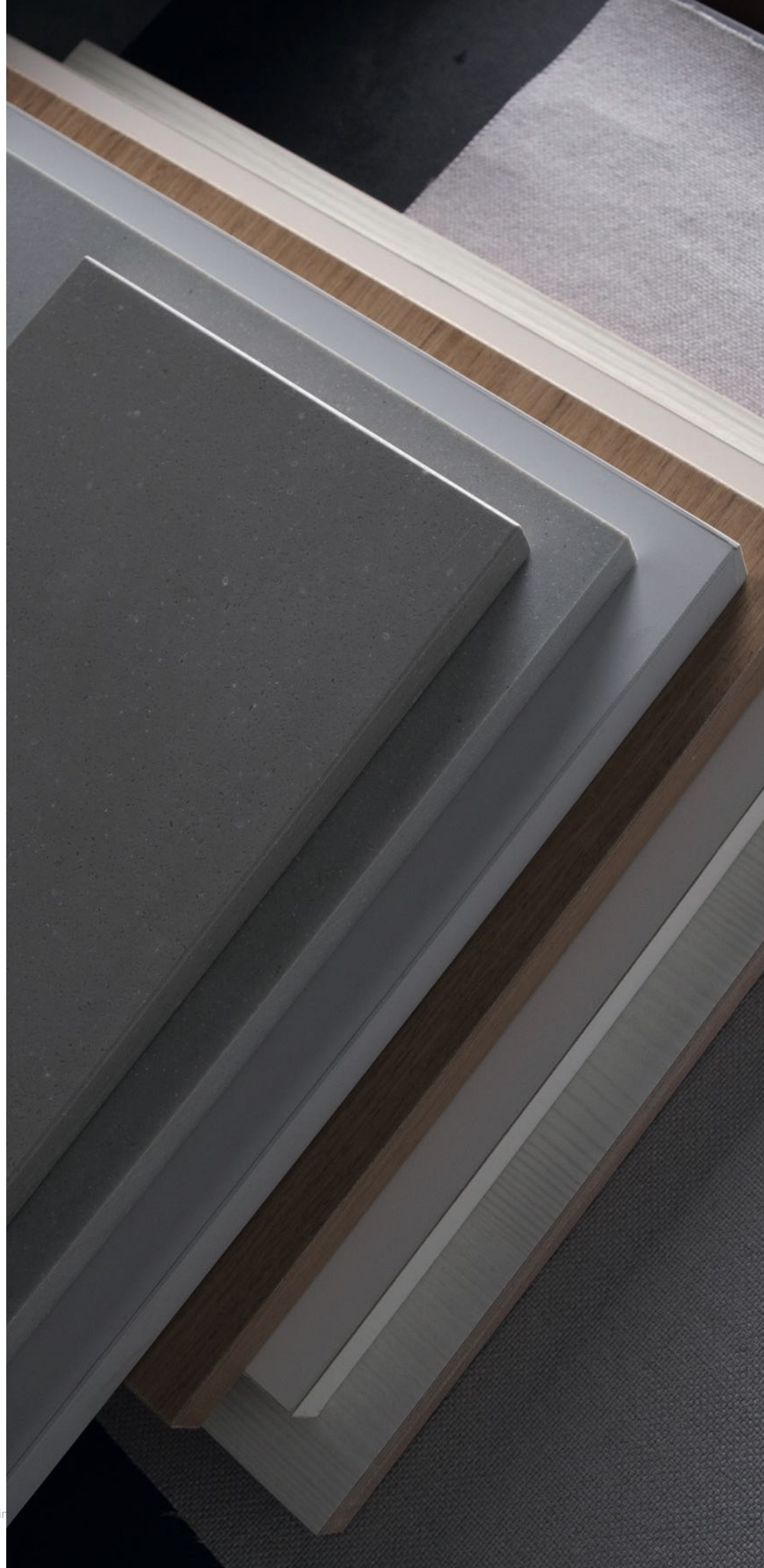

INTERIOR OPTIONS

WOOD

02

WOOD

Honey teak

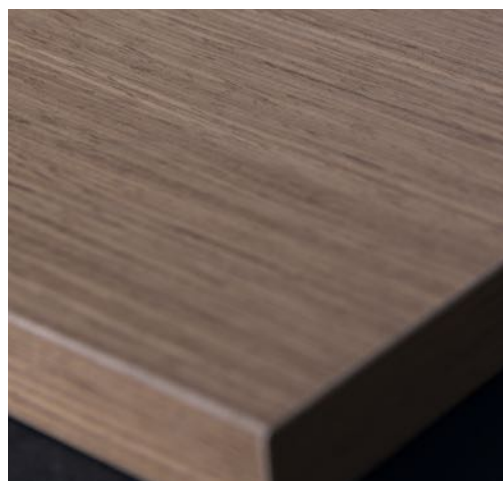

WOOD UPGRADE FINISHING

White lacquered wood

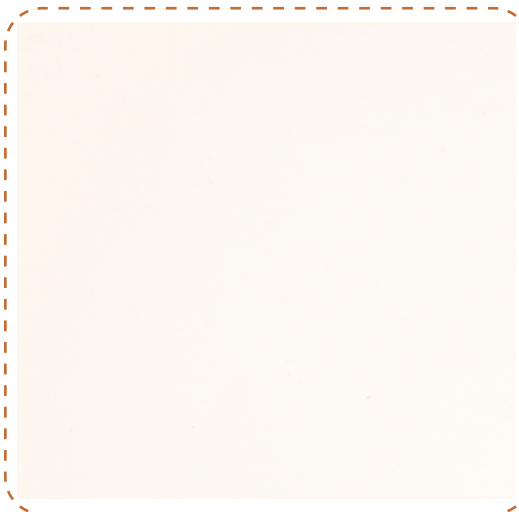

FLOOR

Sand

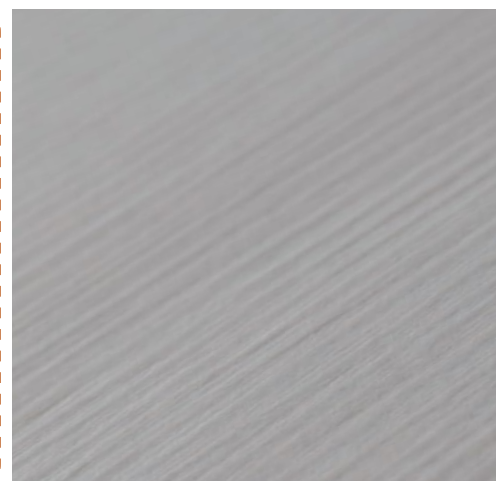

Please note that this **option upgrades the existing standard finish.**

You will enjoy some of same materials as per the standard finish, Honey teak and Sand floor, with bright and elegant touches of lacquered wood. This finish brings to the boat a modern and unique character, a real signature as intended by Nauta to sign the Excess interior style.

INTERIOR OPTIONS

WOOD

02



PICTURE ONBOARD EXCESS 15

WOOD OPTION

Please note here Kerrock and Inside Tailored pack options are included.

1

WOOD
Honey teak



2

FLOOR
Sand

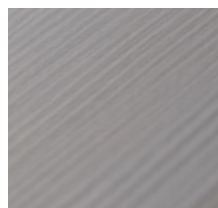

3

SOFA
Silver

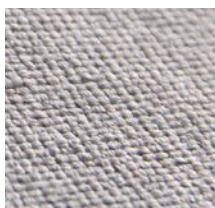

4

GALLEY COUNTERTOP
Laminate | Grigio Sasso

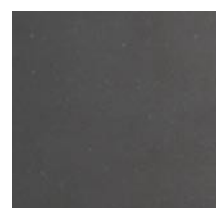

5

WOOD UPGRADE
White lacquer

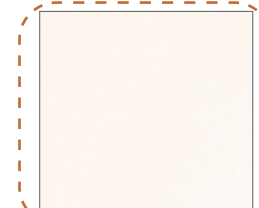

INTERIOR OPTIONS

FLOOR

02

FLOOR OPTIONAL FINISHING

Valley

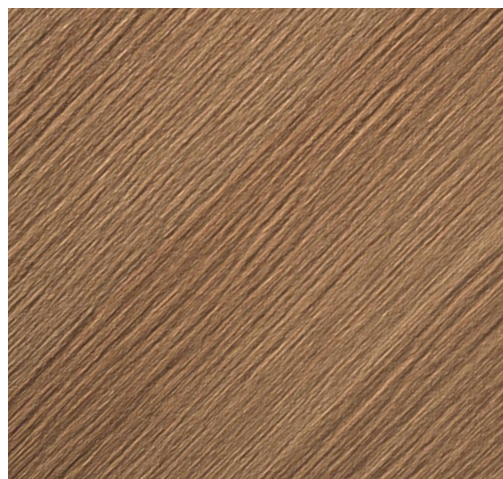

Please note that this **option replaces the existing standard.**

This option is available with Honey teak (standard interior finish) and the White lacquered wood option.

INTERIOR OPTIONS

FLOOR

02



PICTURE ONBOARD EXCESS 15

6

FLOOR UPGRADE Valley

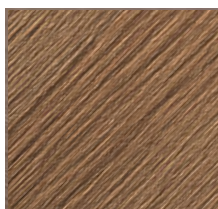

FLOOR OPTION

Please note here White lacquered wood and Inside Tailored pack options are included.

03

INTERIOR TAILORED PACKS

1. Fast & Curious
2. Work Hard Play Hard
3. Less is More



INTERIOR TAILORED PACKS

1. FAST & CURIOUS

03

1. FAST & CURIOUS

SPORT PERFORMANCE TECHNICITY

Lifestyle:

Outside addict, sailing as a sport

Values:

Commitment, work-life balance, well-being

Inside:

- EXTRA FOR FABRIC AND MANUFACTURING FINISHING INTERIOR UPHOLSTERY - Salon and Owner's cabin [**SPARTACUS 21 - Bru®**]
- DECORATIVE CUSHIONS KIT
- LEATHERETTE STORAGES - FOLDER ON BULKHEAD IN LIEU OF STANDARD - cabin [**French Roast**]
- FABRIC AND LEATHERETTE HANGING STORAGES IN LIEU OF STANDARD - cabin [**Fabric : TIGERLILY - Sunbrella® 10222**]
- DOUBLE SETTEE IN FABRIC AND LEATHERETTE - Salon [**SPARTACUS 21 - Bru®** and **French Roast**]

INTERIOR TAILORED PACKS

1. FAST & CURIOUS

03

SOFA



SPARTACUS

STORAGE | Folder on bulkhead

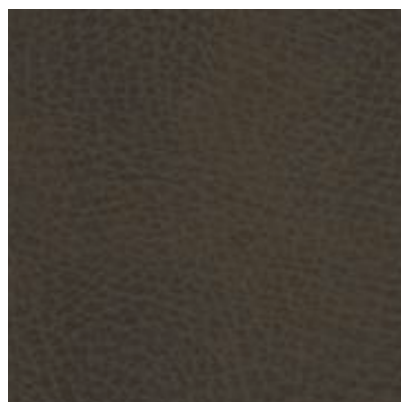

FRENCH ROAST

STORAGE | Hanging storages

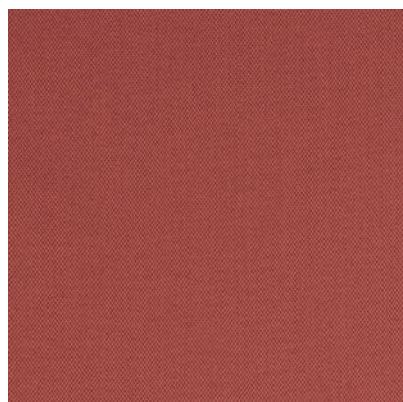

MEZZO TIGERLILY

DECORATIVE CUSHIONS

x1

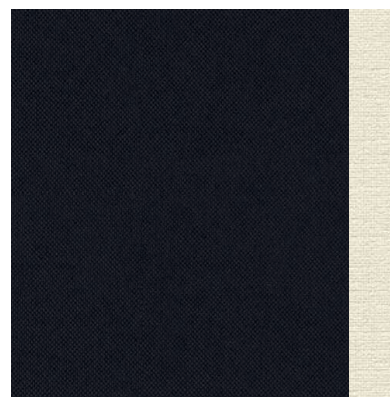

[BRU] PERFORMER LOUNGE JET
[CREVIN] NOAH 01 [Piping]



x2



[CREVIN] NOAH 01
[SUNBRELLA] MEZZO TIGERLILY
10222 140

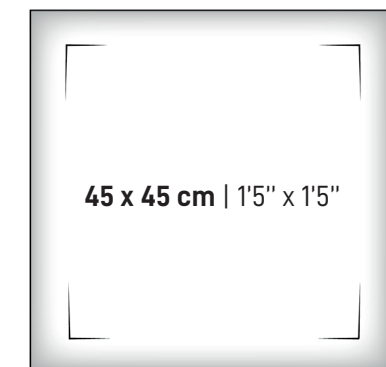

x2

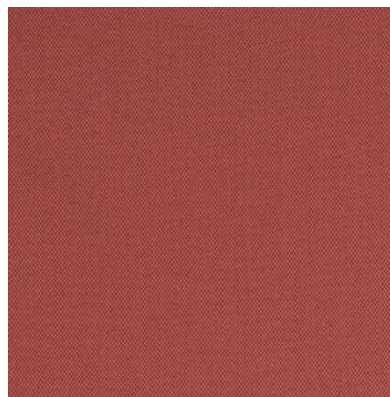

[SUNBRELLA] MEZZO TIGERLILY
10222 140

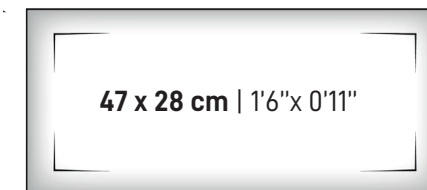

INTERIOR TAILORED PACKS

1. FAST & CURIOUS

03



FAST & CURIOUS

①
Spartacus



SOFA

②
Jet



③
Noah



④
Tigerlily



DECORATIVE CUSHIONS

INTERIOR TAILORED PACKS

2. WORK HARD PLAY HARD

03

2. WORK HARD PLAY HARD

CITY TRENDY SEDUCTION

Lifestyle:

Image-concerned, trend affinity, social, urban

Values:

Independence, status, friends

Inside:

- EXTRA FOR FABRIC AND MANUFACTURING FINISHING INTERIOR UPHOLSTERY - Salon and Owner's cabin **[Divine 45 - Crevin®]**
- DECORATIVE CUSHIONS KIT
- LEATHERETTE STORAGES - FOLDER ON BULKHEAD IN LIEU OF STANDARD - cabin **[French Roast]**
- FABRIC AND LEATHERETTE HANGING STORAGES IN LIEU OF STANDARD - cabin **[Fabric : TIGERLILY - Sunbrella® 10222]**
- DOUBLE SETTEE IN FABRIC AND LEATHERETTE - Salon **[Divine 45 - Crevin® and French Roast]**

INTERIOR TAILORED PACKS

2. WORK HARD PLAY HARD

03

SOFA



DIVINE

STORAGE | Folder on bulkhead

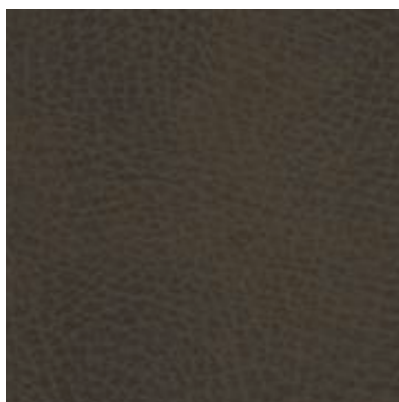

FRENCH ROAST

STORAGE | Hanging storages



MEZZO TIGERLILY

DECORATIVE CUSHIONS

x1

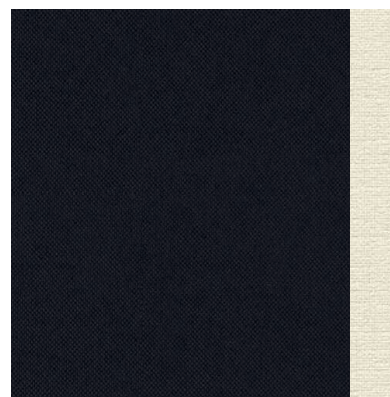

[BRU] PERFORMER LOUNGE JET
[CREVIN] NOAH 01 [Piping]



45 x 45 cm | 1'5" x 1'5"

x2

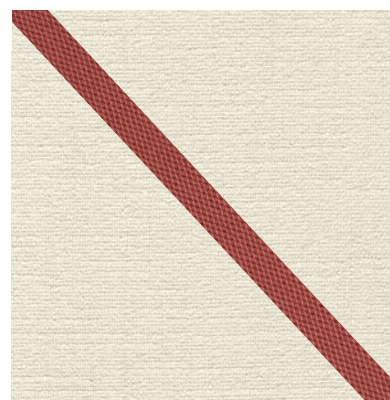

[CREVIN] NOAH 01
[SUNBRELLA] MEZZO TIGERLILY
10222 140

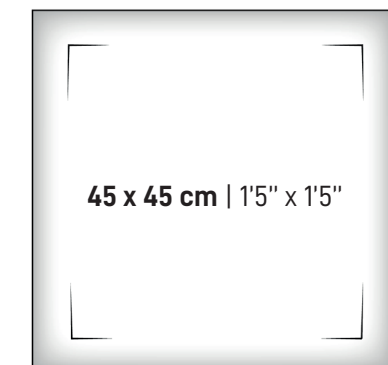

45 x 45 cm | 1'5" x 1'5"

x2

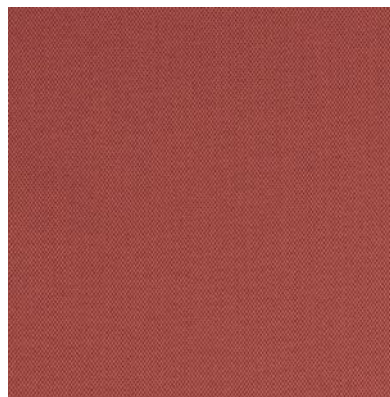

[SUNBRELLA] MEZZO TIGERLILY
10222 140

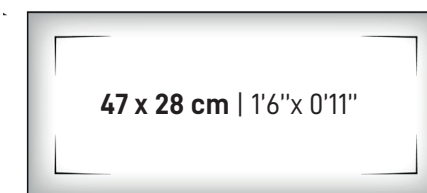

47 x 28 cm | 1'6" x 0'11"

INTERIOR TAILORED PACKS

2. WORK HARD PLAY HARD

03



①

Divine



SOFA

②

Jet



③

Noah



④

Tigerlily

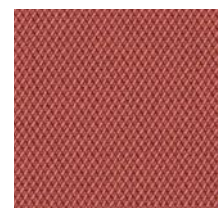

DECORATIVE CUSHIONS

WORK HARD
PLAY HARD

3. LESS IS MORE

SPORT CHIC, PREPPY TRAVELER

Lifestyle:

Love simple pleasure, freedom

Values:

Rationality, fairness, simplicity

Inside:

- EXTRA FOR FABRIC AND MANUFACTURING FINISHING INTERIOR UPHOLSTERY: Salon and Owner's cabin [**Trailblazer 29 - Bru®**]
- DECORATIVE CUSHIONS KIT
- LEATHERETTE STORAGES - FOLDER ON BULKHEAD IN LIEU OF STANDARD - cabin [**French Roast**]
- FABRIC AND LEATHERETTE HANGING STORAGES IN LIEU OF STANDARD - cabin [**Fabric : TIGERLILY - Sunbrella® 10222**]
- DOUBLE SETTEE IN FABRIC AND LEATHERETTE - Salon [**Trailblazer 29 - Bru®** and **French Roast**]

INTERIOR TAILORED PACKS

3. LESS IS MORE

SOFA



TRAILBLAZER

STORAGE | Folder on bulkhead

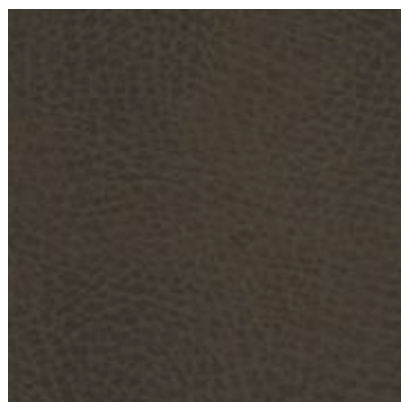

FRENCH ROAST

STORAGE | Hanging storages



MEZZO TIGERLILY

DECORATIVE CUSHIONS

x1

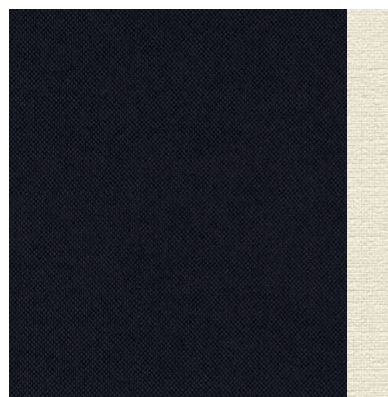

[BRU] PERFORMER LOUNGE JET
[CREVIN] NOAH 01 [Piping]



x2

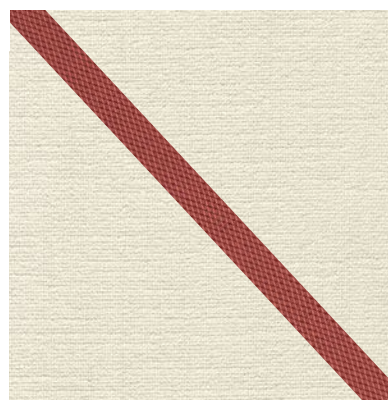

[CREVIN] NOAH 01
[SUNBRELLA] MEZZO TIGERLILY
10222 140

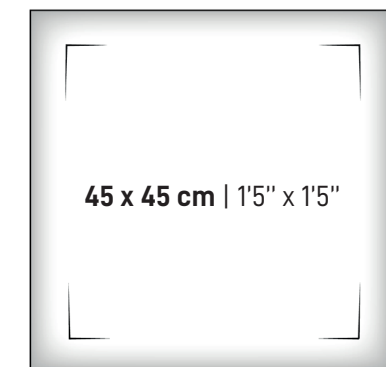

x2

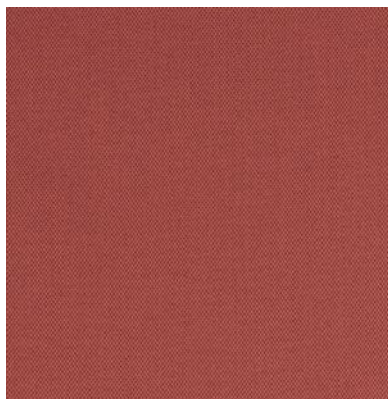

[SUNBRELLA] MEZZO TIGERLILY
10222 140

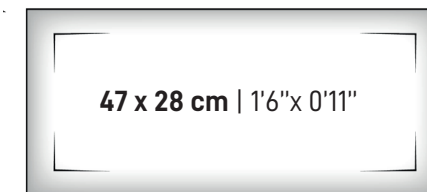

INTERIOR TAILORED PACKS

3. LESS IS MORE

03

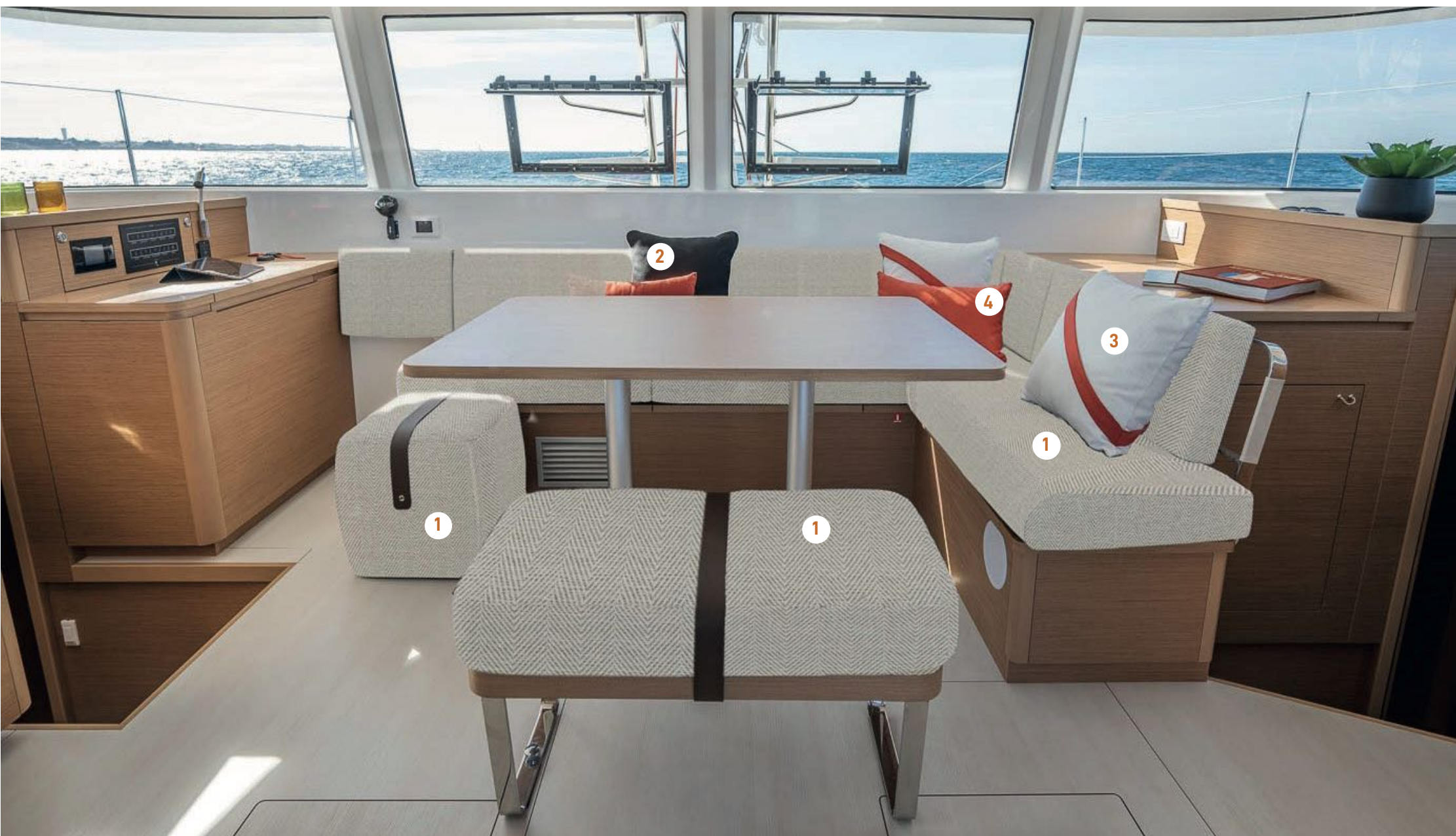

LESS IS MORE



04

EXTERIOR

1. Upholstery
2. Canvas



EXTERIOR

1. UPHOLSTERY

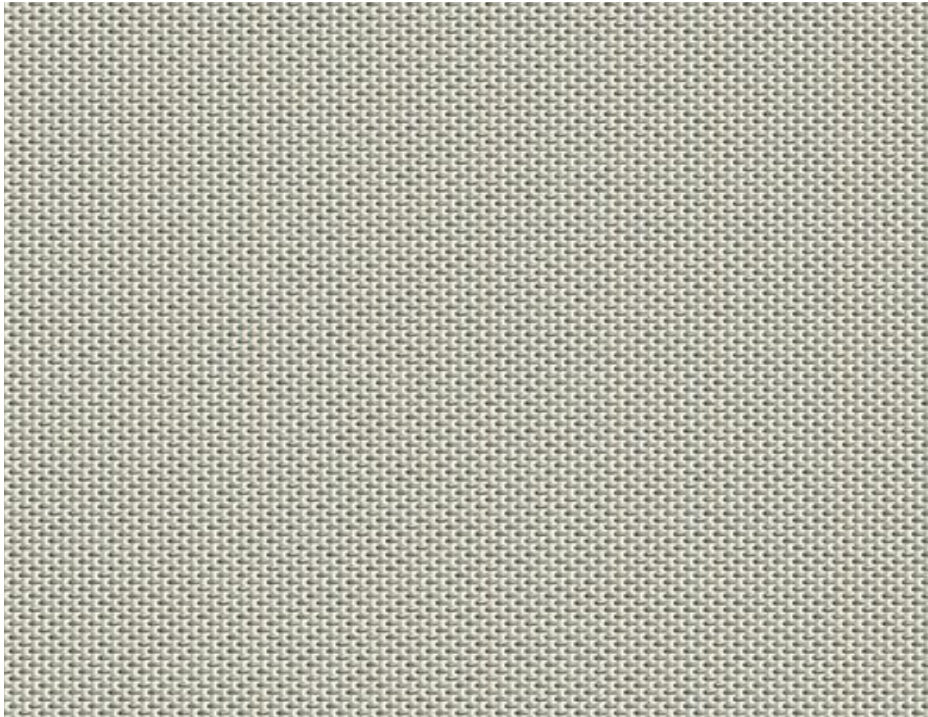

Grey

Serge Ferrari®
Batyline - Lounge
7720FR-50932

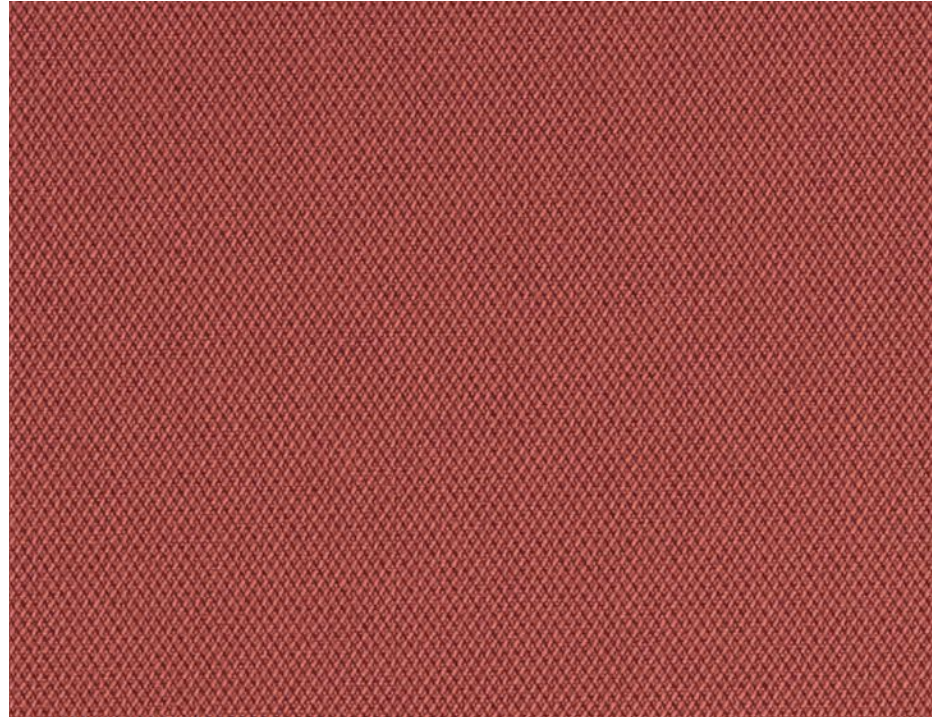

Orange

Sunbrella®
MEZZO - Tigerlily
MEZZ 10222 140

Canvas

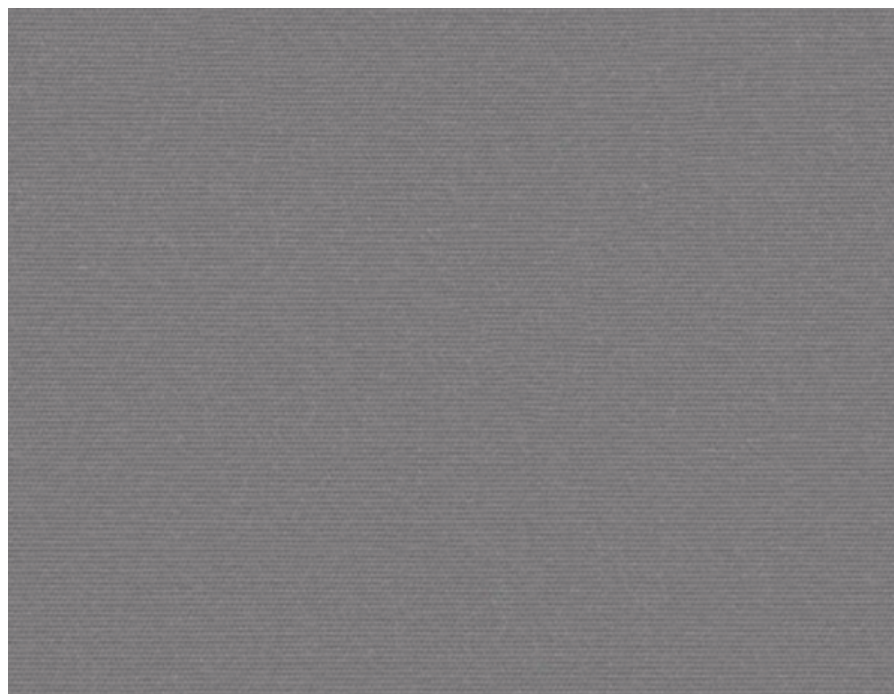

Cadet Grey
Sunbrella®
SUNTT 5530 152

Lazy bag

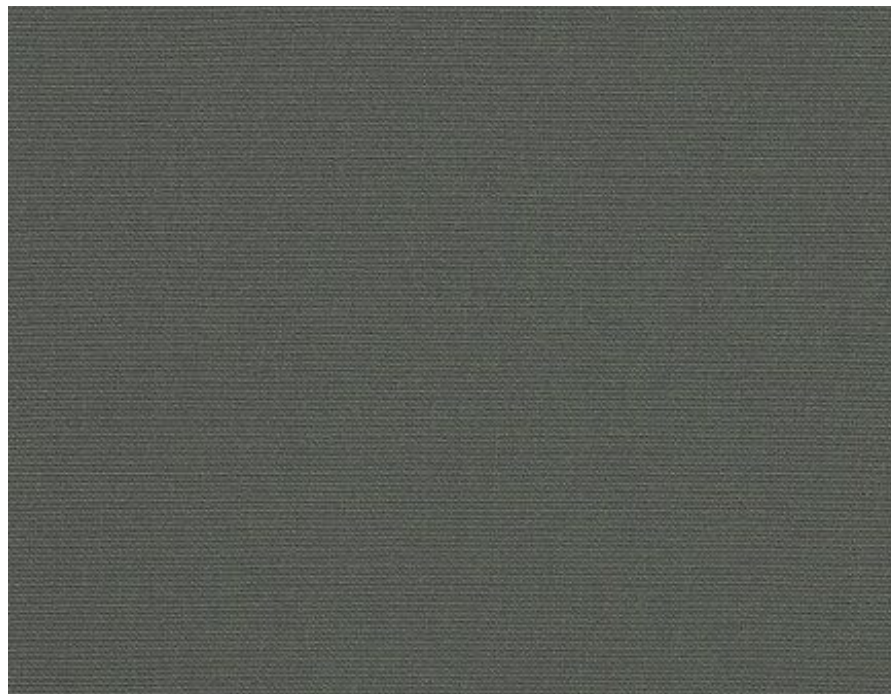

Charcoal Grey
Sunbrella®
4644-0000



04

TECHNICAL DATA

01 SPECIFICATIONS

02 ELECTRICITY

03 FLUIDS

04 LAYOUTS

05 VPP

06 BERTH-MATTRESS

This chapter contains all the main technical information you need to know about Excess 14.

01

SPECIFICATIONS

SPECIFICATIONS

01

Launching year
Naval architect
Interior design

2022 [September]
VPLP Design
Nauta Design

BUILD

Hulls: Sides|Bottom

Infused balsa cored sandwich|Solid glass with anti-osmotic and polyester resins.

Deck

Infused PET foam cored sandwich with polyester resin.

Roof

Infused carbon-reinforced laminate. Balsa cored sandwich|Solid glass with polyester resin.

Bulkheads

Carbon-reinforced infused PET foam/plywood cored sandwich with polyester resin.

SPECIFICATIONS

Maximum length

15.99 m | 52'5"

Overall length

13.97 m | 45'9"

Hull length

13.34 m | 43'9"

Beam

7.87 m | 25'9"

Draft

1.48 m | 4'10"

Mast clearance [std. / Pulse Line]

19.78 m | 64'11" / **21.54 m** | 70'8"

Light displacement [Mlc]

12,800 kg | 28,219 lbs

Max. loaded displacement [MLDC]

17,700 kg | 39,029 lbs

Number of berths

6 - 12

EC certification

A : 10 - B : 12 - C : 16 - D : 20

SAILS

STANDARD SAIL PLAN

Upwind sail area

123 m² | 1,323 sq ft

Square top mainsail

83 m² | 893 sq ft

Overlapping genoa

40 m² | 430 sq ft

Code 0 [opt.]

72 m² | 775 sq ft

I forestay

15.50 m | 50'10"

J mast front face-forestay

5.09 m | 16'8"

P mainsail

16.00 m | 52'5"

E boom

7.15 m | 23'5"

SPECIFICATIONS

01

PULSE LINE SAIL PLAN

Upwind sail area	135 m² 1,453 sq ft
Square top mainsail	90 m² 968 sq ft
Overlapping genoa	45 m² 484 sq ft
Code 0 [opt.]	86 m² 925 sq ft
I forestay	17.00 m 55'9"
J mast front face-forestay	5.09 m 16'8"
P mainsail	17.70 m 58'0"
E boom	7.15 m 23'5"

ENGINES

Engine [std.]	2 x 45 HP
Engine [opt.]	2 x 57 HP
Transmission	Sail drive
Fixed propeller [std. 45HP]	18" x 14 3 blades
Fixed propeller [opt. 57HP]	18" x 15 3 blades
Foldable propeller [opt. 45HP]	17" x 14 3 blades
Foldable propeller [opt. 57HP]	18" x 14 3 blades

CAPACITIES

Fuel	2 x 200 L 2 x 53 US gal
Fresh water [std. & opt.]	300 L 79 US gal + 300 L 79 US gal
Black water	2 x 80 L 2 x 21 US gal
Water heater	40 L 11 US gal
Refrigerator salon [std. + opt.]	130 L 34 US gal + 130 L 34 US gal
Refrigerator cockpit [std.]	75 L 20 US gal
Fridge/freezer [opt.]	90/65 L 24/17 US gal

ELECTRICITY

Engine battery [std.]	2 x 50 A [AGM]
Main battery bank [std + Sail Away]	[2 + 4] x 95 A [AGM]
Main battery bank [opt.]	4 x 90 A [Lithium]
Generator prefitting [opt.]	7KVA 230V50Hz 9KVA 110V60H

SHORE POWER

AC circuit [Sail Away]

[230 V] 1 x 32 A | [110 V] 1 x 32 A

Air Conditioning [opt.]

[230 V] 1 x 32 A | [110 V] 1 x 50 A*

DINGHY, LIFE RAFT & MOORING

DINGHY [opt.]

CL 310 + 15 HP Honda

MOORING

Windlass

LEWMAR 1,500W 12 V

Anchor [opt.]

DELTA **20 kg** | 44 lbs

Chain [opt.]

75 m - Ø 10 mm | 246'06" - Ø3|8

Rope [opt.]

20 m - Ø 18 mm | 65'61" - Ø3|4

Fenders [qty. 6]

860 mm - Ø230 mm | 2'10" - Ø9 1|16

Dock lines [opt]

4x15m - Ø20 mm | 4 x 49'3" - Ø25|32

*1 x 50A shore power option replaces the 32A shore power [SAIL AWAY].

230V Total: x2 | 120V Total: x1

02

ELECTRICITY

SOON TO COME

03

FLUIDS

SOON TO COME

04

LAYOUTS

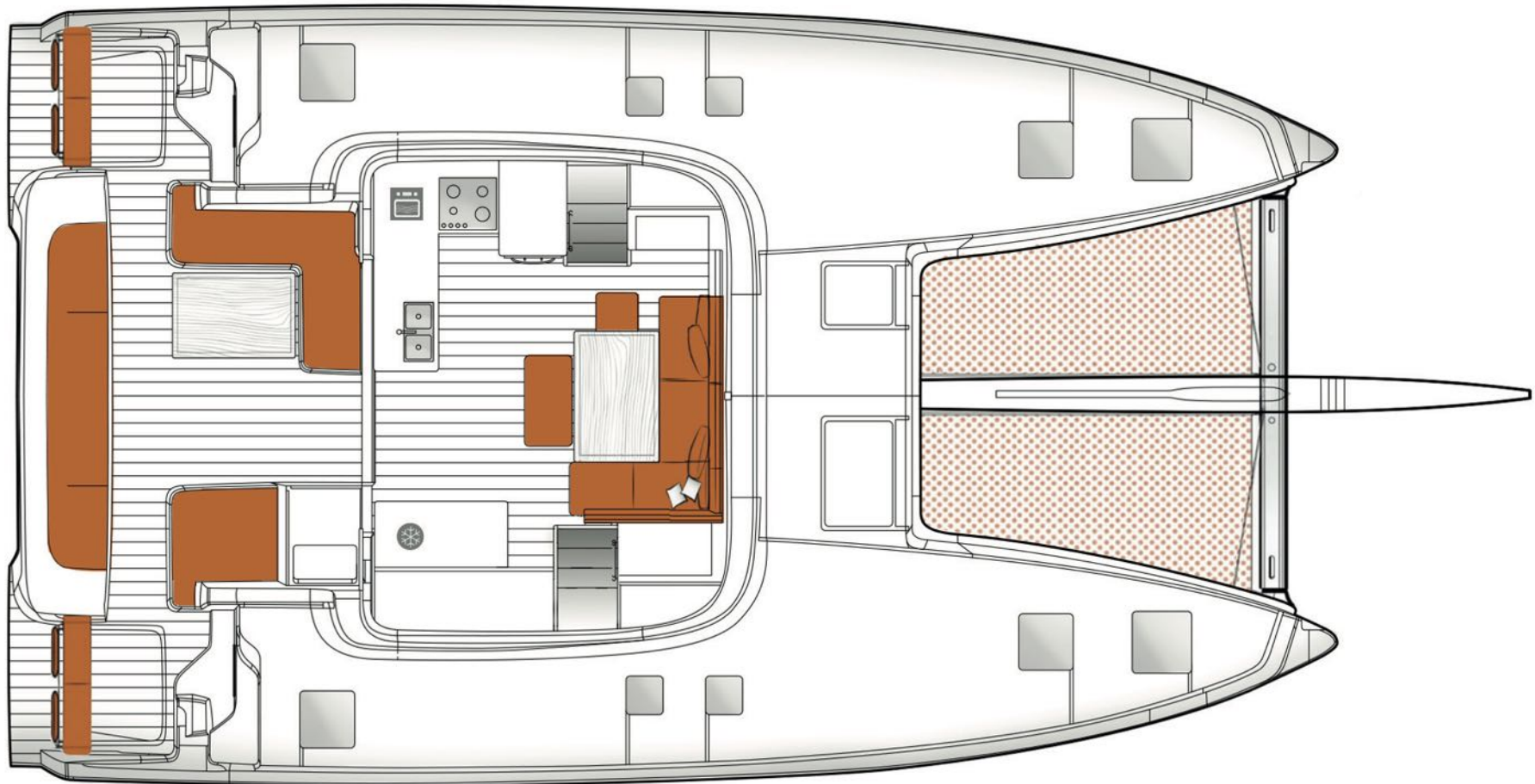

SALON - COCKPIT

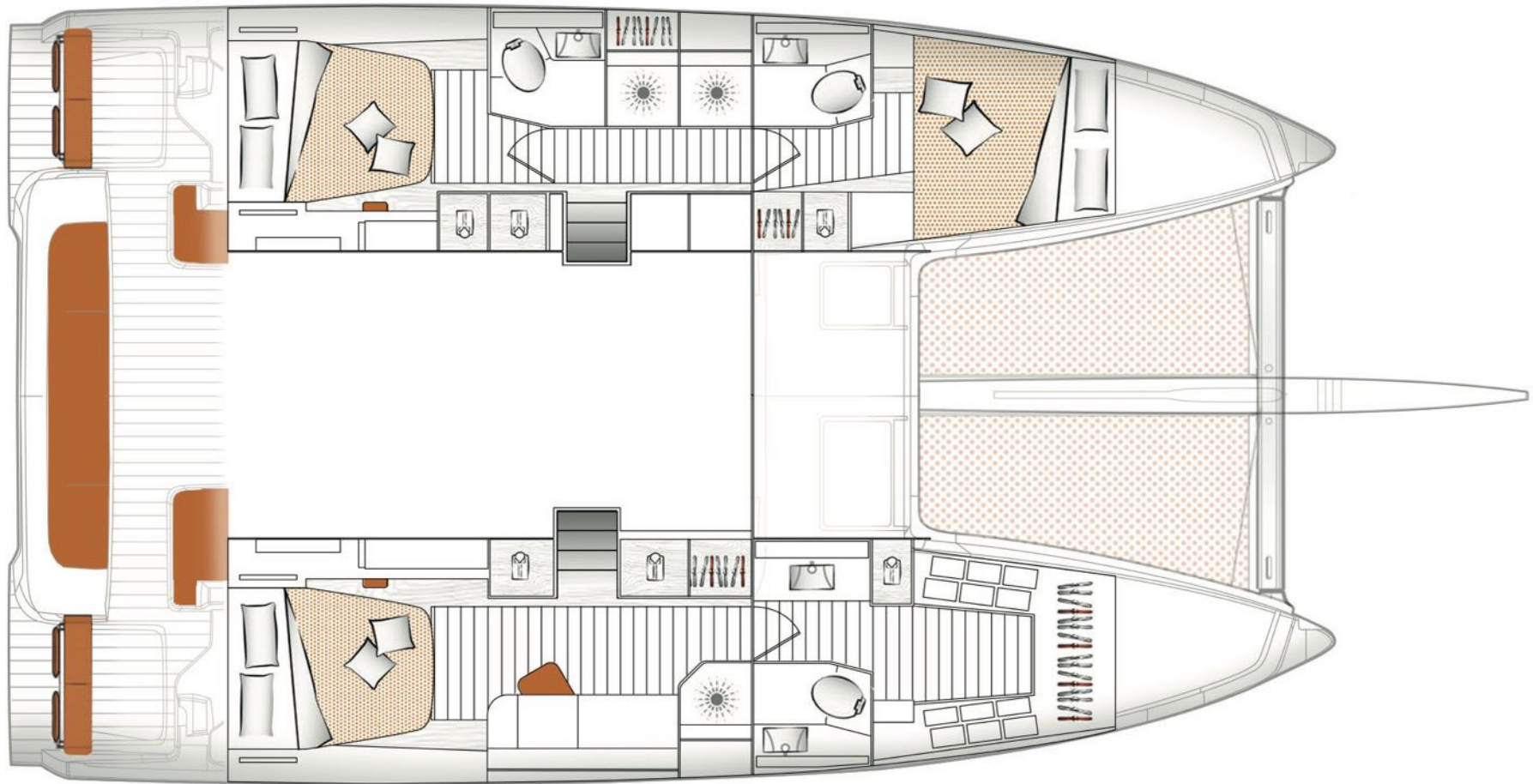

3 CABIN 3 HEAD VERSION

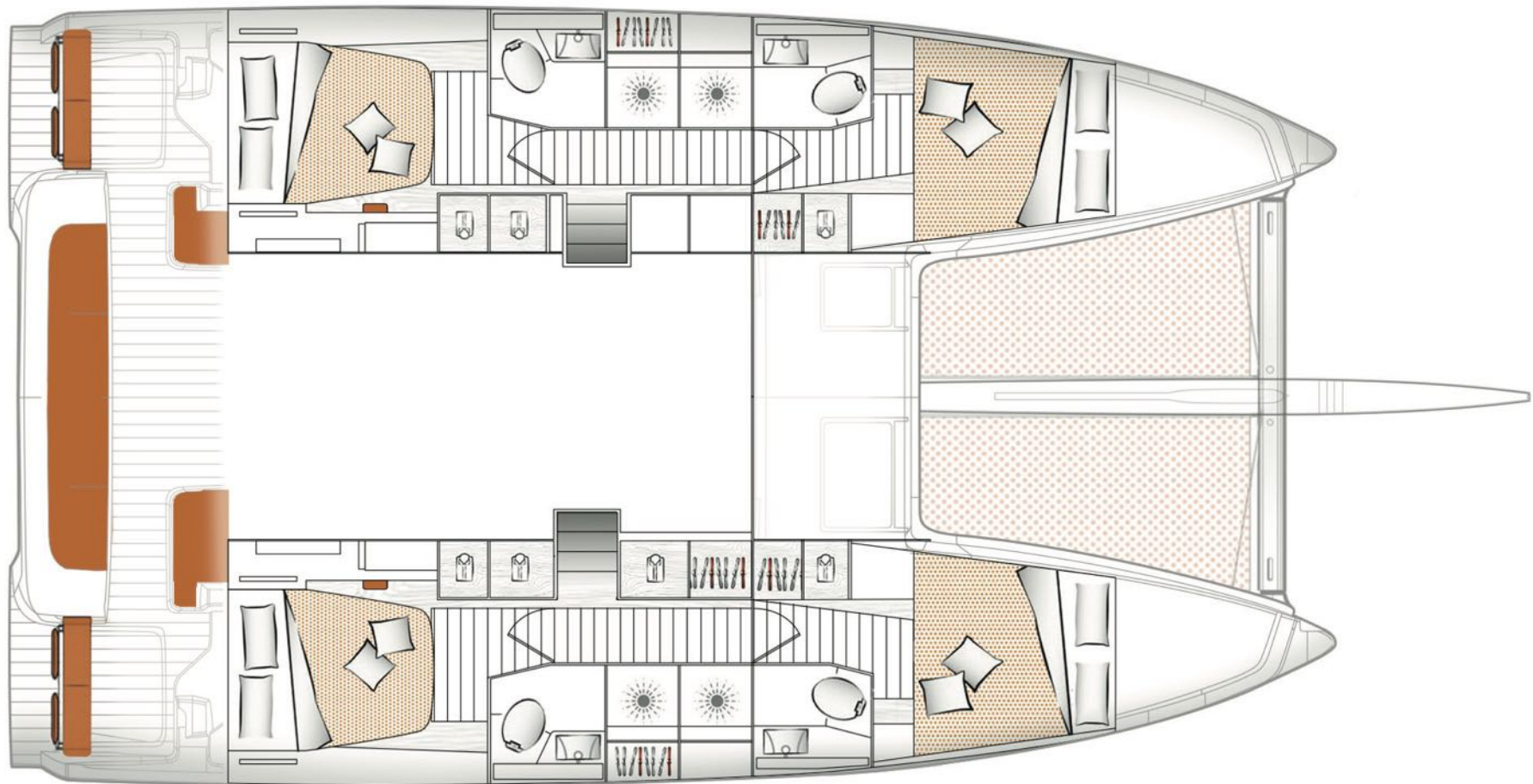

4 CABIN 4 HEAD VERSION

05

VPP

SOON TO COME

06

BERTHS-MATTRESS

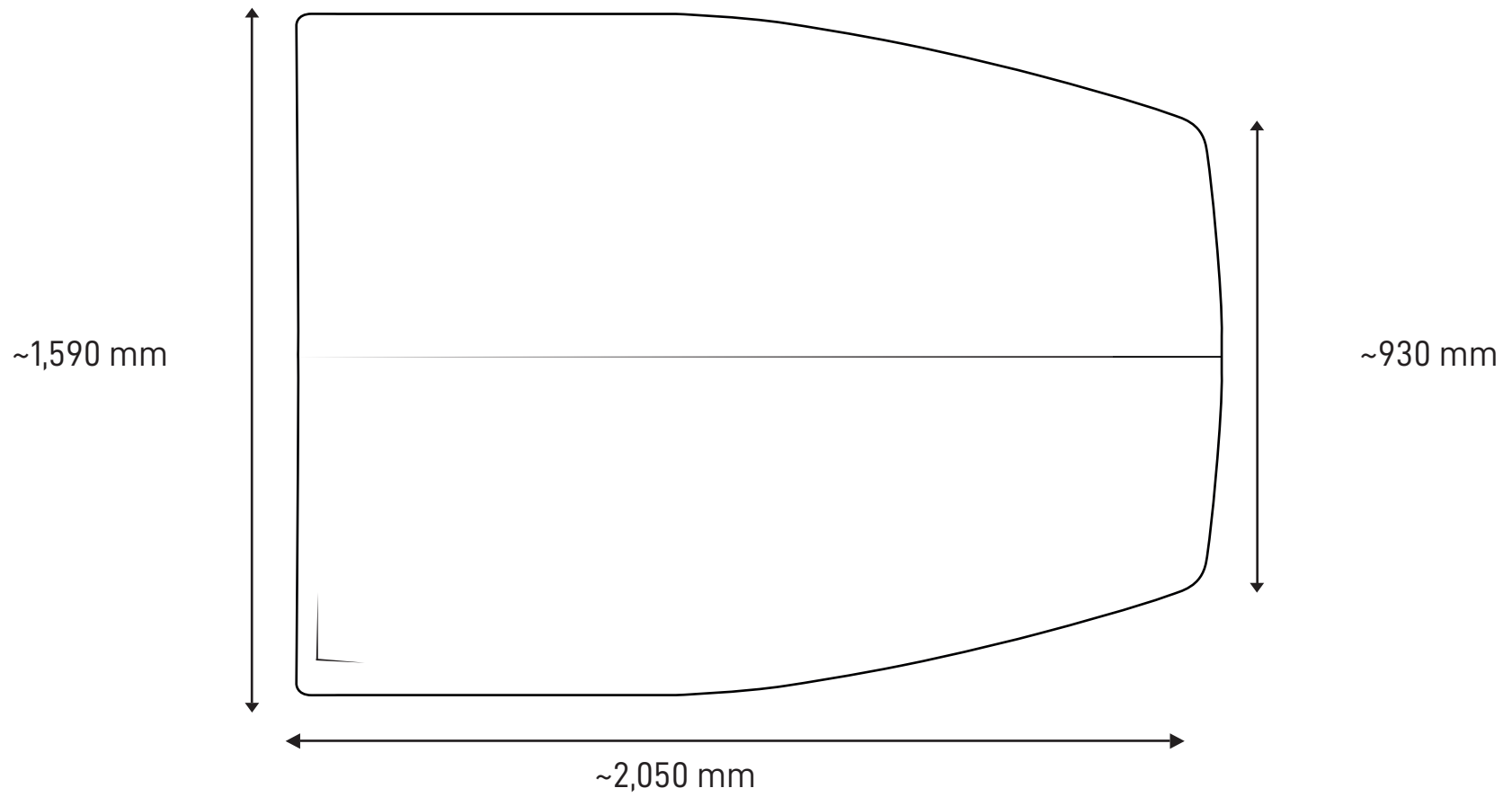

Thickness: 120 mm

AFT CABINS [SAME FOR OWNER CABIN]

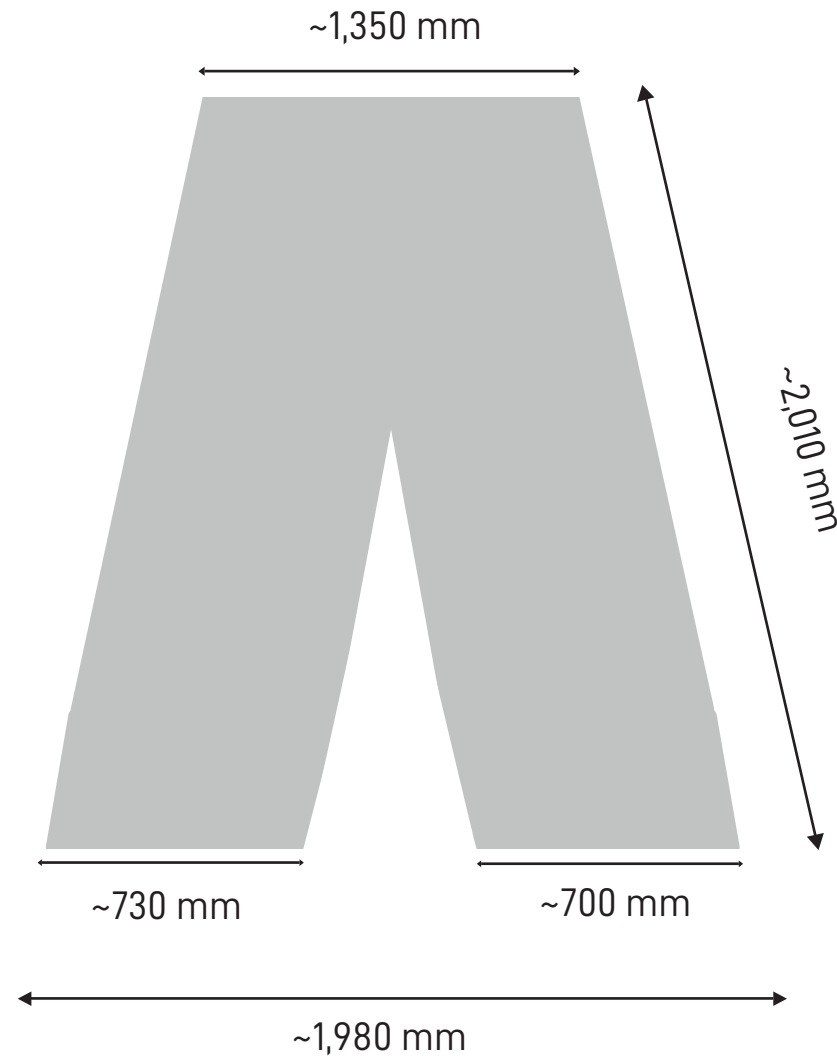

Thickness: 100 mm

TWIN BERTHS [OWNER CABIN]

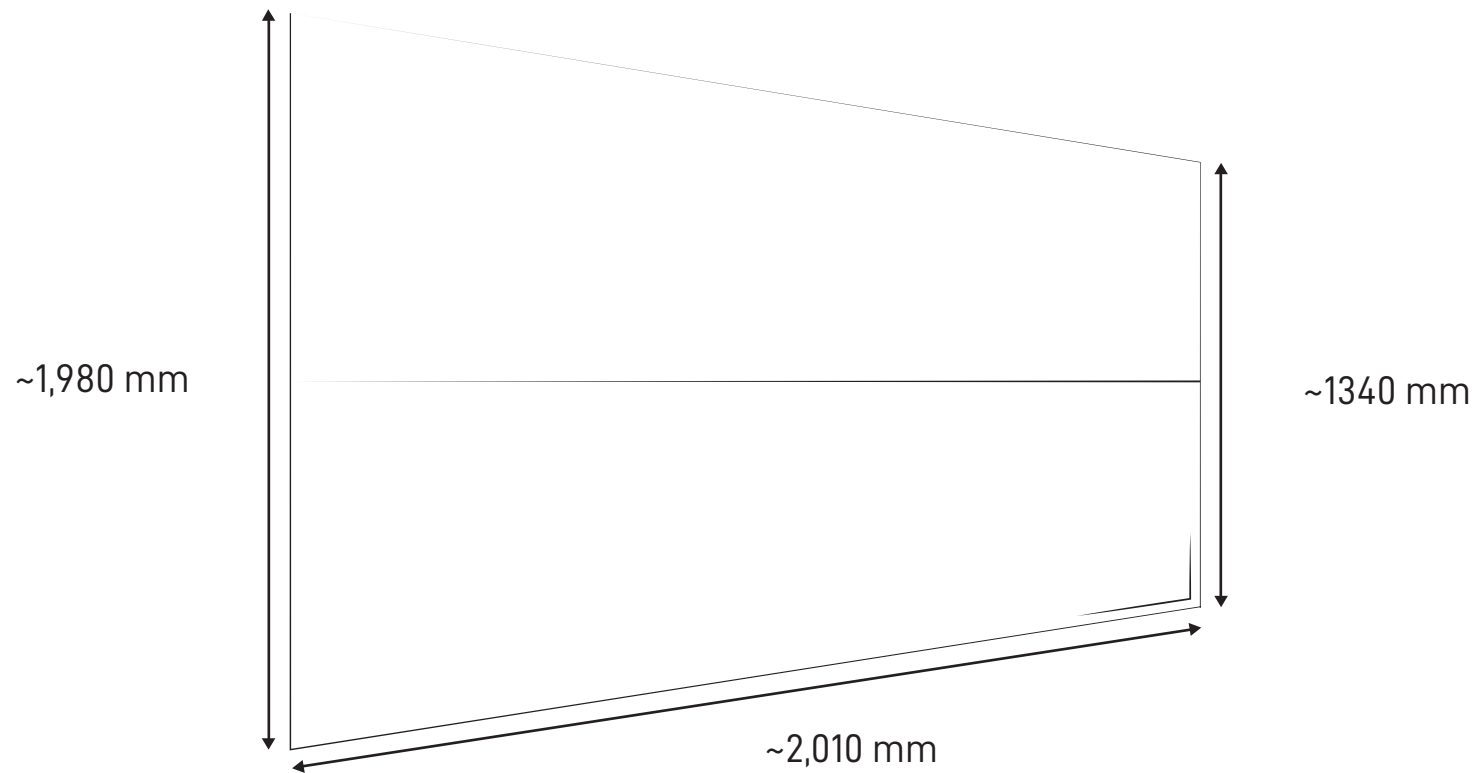

Thickness: 120 mm

FORWARD CABINS

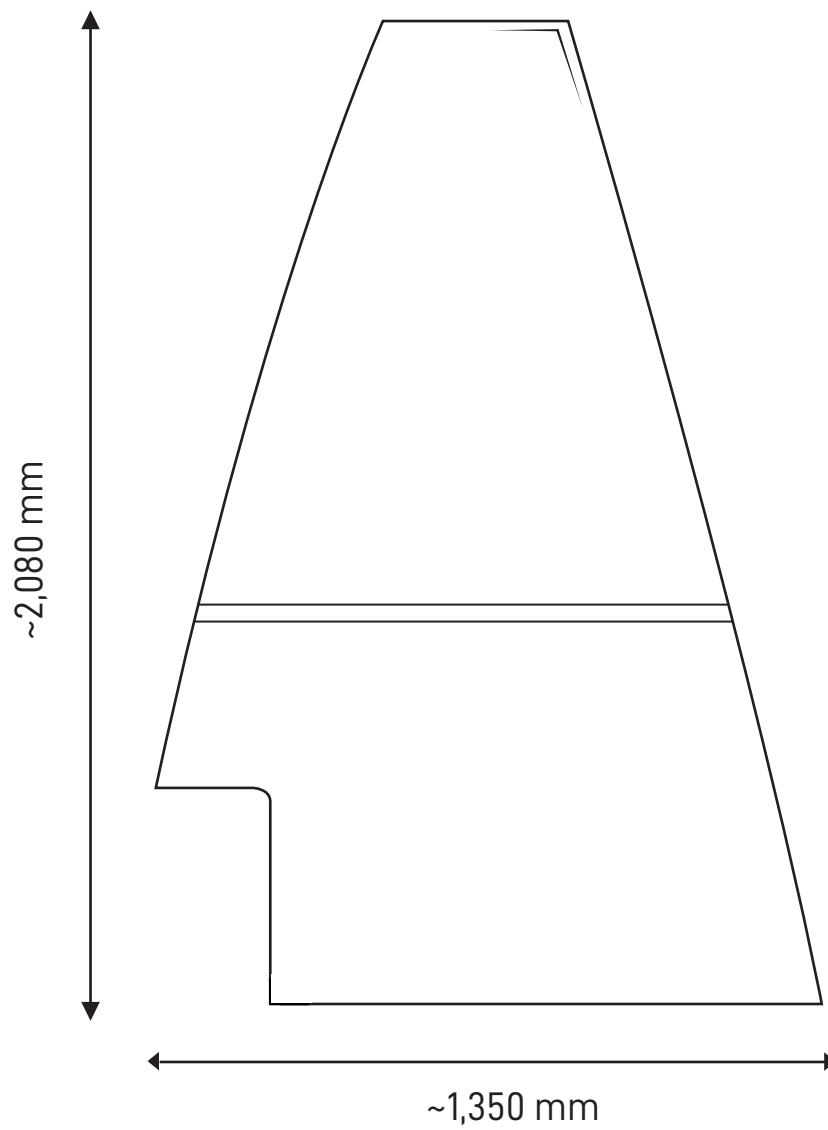

BOW COMPARTMENTS



EXCESS-CATAMARANS.COM